

**KRISHNA
SUPPORT STUDY
MATERIAL**

XII Chemistry

**Study Material,
Support Material,
Study Notes,
HOTS and VBO**

CONTENTS

S. No.	Chapter	Page
	Important Formulas of Physical Chemistry	1-10
1.	The Solid State	11-17
2.	Solutions	18-26
3.	Electro Chemistry	27-35
4.	Chemical Kinetics	36-42
5.	Surface Chemistry	43-47
6.	General Principles and Processes of Isolation of Elements	48-52
7.	The p- Block Elements	53-75
8.	d- and f- Block Elements	76-92
9.	Co-ordination Compounds	93-97
10.	Haloalkanes and Haloarenes	98-112
11.	Alcohols, Phenols and Ethers	113-121
12.	Aldehydes, Ketones and Carboxylic Acids	122-130
13.	Amines	131-135
14.	Biomolecules	136-140
15.	Polymers	141-145
16.	Chemistry in Every Day Life	146-152
	<i>Model Papers</i>	153-181

Important Formulas of Physical Chemistry

THE SOLID STATE

1. Calculation of number of particles / atoms / ions in a Unit Cell :

Type of Unit Cell	Numer of particles per Unit Cell	Relationship between edge length (a) and radius (r) of atom/ion
Simple cubic	1	$a = 2r$
Body centred cubic	2	$a = \frac{4}{\sqrt{3}} r$
Face centred cubic	4	$a = 2\sqrt{2} r$

3. Density of unit cell (d)

$$d = \frac{Z \times M}{a^3 \times N_A}$$

Where **Z** is rank of unit cell (no. of atoms per unit cell), **m** is molar mass/ atomic mass, 'a' is edge length of the cube, 'a³' is volume of cubic unit cell and **N_A** is Avogadro number.

4. Packing efficiency = $\frac{d \times N_A}{M} \times \frac{4}{3} \pi r^3 \times 100$

Here 'M' is molar mass 'r' is radius of atom, 'd' is density and **N_A** is Avogadro's number ($6.022 \times 10^{23} \text{ mol}^{-1}$).

Rank of unit cell can be computed by packing efficiency value

Type of Unit Cell	Packing efficiency	Rank of Unit Cell
SC	52.4%	1
BCC	68.0%	2
FCC	74%	4

Solution

1. Mole fraction (x)

if the number of moles of A and B are n_A and n_B respectively, the mole fraction of A and B will be

$$x_A = \frac{n_A}{n_A + n_B}, \text{ and } x_B = \frac{n_B}{n_A + n_B}$$

$$x_A + x_B = 1$$

2. **Molarity (M)** = $\frac{\text{Moles of solute}}{\text{Volume of solution in litres}}$

3. **Moality (m)** = $\frac{\text{Moles of solute}}{\text{Mass of solvent in kilograms}}$

4. Parts per million (ppm)

$$= \frac{\text{Number of parts of the component}}{\text{Total number of parts of all components of the solution}} \times 10^6$$

5. Raoult's law for a solution of volatile solute in volatile solvent :

$$p_A = p_A^\circ x_A$$

$$p_B = p_B^\circ x_B$$

Where p_A and p_B are partial vapour pressures of component 'A' and component 'B' in solution. p_A° and p_B° are vapour pressures of pure components 'A' and 'B' respectively.

6. Raoult's law for a solution of non-volatile solute and volatile solvent :

$$\frac{p_A^\circ - p_A}{p_A^\circ} = i x_B \approx i \frac{n_B}{N_A} = i \frac{W_B \times M_A}{M_B \times W_A} \text{ (for dilute solution)}$$

Where x_B is mole fraction of solute, i is van't Hoff factor and $\frac{p_A^\circ - p_A}{p_A^\circ}$ is relative lowering of vapour pressure.

7. **Elevation in boiling point (ΔT_b)**

$$\Delta T_b = i \cdot K_b \cdot m$$

where $\Delta T_b = T_b - T_b^\circ$

K_b = molal boiling point elevation constant

m = molality of solution.

8. **Depression in freezing point (ΔT_f)**

$$\Delta T_f = i \cdot K_f \cdot m$$

where $\Delta T_f = T_f^\circ - T_f$

K_f = molal depression constant

m = molality of solution.

9. **Osmotic pressure (π) of a solution**

$$\pi V = inRT \quad \text{or} \quad \pi = i CRT$$

where π = osmotic pressure in bar or atm

V = volume in litres

i = Van't Hoff factor

c = molar concentration in moles per litres

n = number of moles

T = Temperature on Kelvin Scale

$R = 0.083 \text{ L bar mol}^{-1} \text{ K}^{-1}$

$R = 0.0821 \text{ L atm mol}^{-1} \text{ K}^{-1}$

10. **Van't Hoff factor (i)**

$$i = \frac{\text{Observed colligative property}}{\text{Theoretically calculated colligative property}}$$

$$i = \frac{\text{Normal molar mass}}{\text{Abnormal molar mass}}$$

$$\begin{cases} i > 1 & \text{For dissociation of molecules} \\ i < 1 & \text{For association of molecules} \\ i = 1 & \text{For ideal solution} \end{cases}$$

11. **Relationship between relative lowering in vapour pressure and elevation in b.p.**

$$\frac{\Delta p}{p_A^\circ} = i \frac{\Delta T_b}{K_b} M_A \times 1000$$

Here

Δp is lowering in vapour pressure, p_A° is vapour pressure of pure solvent, i is van't Hoff factor, ΔT_b is elevation in boiling point, K_b is molal elevation constant and M_A is molar mass of solvent

Electrochemistry

1. **Conductivity (k)**

$$K = \frac{1}{P} = \frac{1}{R} \times \frac{l}{A} = G \times G^*$$

Where R is resistance, $l/A = \text{cell constant } (G^*)$ and $\frac{1}{P}$ is resistivity.

2. Relationship between k and Λ_m

$$\Lambda_m = \frac{1000 \times k}{c}$$

Where Λ_m is molar conductance, k is conductivity and C is molar concentration.

Kohlrausch's law

(a) In general if an electrolyte on dissociation gives v_+ cations and γ_- anions then, its limiting molar conductivity is given by

$$\Lambda_m^\circ = \gamma_+ \lambda_+^\circ + \gamma_- \lambda_-^\circ$$

Here λ_+° and λ_-° are the limiting molar conductivities of cation and anion respectively and v_+ and v_- are the number of cations and anions furnished by one formula unit.

(b) **Degree of dissociation (α)** is given by :

$$\alpha = \frac{\Lambda_m^c}{\Lambda_m^\circ}$$

Here Λ_m° is molar conductivity at the concentration C and Λ_m° is limiting molar conductivity of the electrolyte.

(c) Dissociation constant (K.) of weak electrolyte

$$K = \frac{C\alpha^2}{1-\alpha} = \frac{C \left(\frac{\Lambda_m^c}{\Lambda_m^\circ} \right)^2}{\left(1 - \frac{\Lambda_m^c}{\Lambda_m^\circ} \right)}$$

3. **Nernst Equation for electrode reaction : $M^{n+} + ne^- \rightarrow M$.**

$$E = E^\theta - \frac{2.303 RT}{nF} \log \frac{1}{[M^{n+}]}$$

For Cell potential of electrochemical reaction $aA : bB \xrightarrow{ne^-} cC + dD$

$$E_{\text{cell}} = E_{\text{cell}}^\theta - \frac{2.303RT}{nF} \log [Q_c]$$

4. **Relationship between E^θ cell and equilibrium constant (K_c)**

$$E^\theta_{\text{cell}} = \frac{2.303RT}{nF} \log K_c$$

$$E^\theta_{\text{cell}} = \frac{0.059V}{n} \log K_c$$

5. $\Delta G^\theta = - nF E^\theta_{\text{cell}}$

Where ΔG^θ = standard Gibbs energy change and nF is the amount of charge passed.

$$\Delta G^\theta = - 2.303 RT \log K_c$$

Chemical Kinetics

1. Integrated rate law equation for zero order reaction

$$(a) \quad k = \frac{[R]_0 - [R]}{t}$$

Where k is rate constant and $[R]_0$ is initial molar concentration.

$$(b) \quad t_{1/2} = \frac{[R]_0}{2k}$$

$t_{1/2}$ is half life period of zero order reaction.

2. Integrated rate law equation for first order reaction

$$(a) \quad k = \frac{2.303}{t} \log \frac{[R]_0}{[R]}$$

Where k is rate constant, $[R]_0$ is initial molar concentration and $[R]$ is final concentration at time 't'.

(b) Half life period ($t_{1/2}$) for first order reaction :

$$t_{1/2} = \frac{0.693}{k}$$

3. Arrhenius equation

$$(a) \quad k = A e^{-E_a/RT}$$

Where 'A' is frequency factor, E_a is the energy of activation, R is universal gas constant and T is absolute temperature.

$e^{-E_a/RT}$ gives the fraction of collisions having energy equal to or greater than E_a .

$$(b) \quad \log \frac{k_2}{k_1} = \frac{E_a}{2.303 R} \left(\frac{T_2 - T_1}{T_1 T_2} \right)$$

Where k_1 is rate constant at temperature T_1 and k_2 is rate constant at temperature T_2 .

Unit-1
THE SOLID STATE

QUESTIONS

VSA QUESTIONS (1 - MARK QUESTIONS)

1. What are anisotropic substances.
2. Why are amorphous solids isotropic in nature?
3. Why glass is regarded as an amorphous solid?
4. Define the term 'crystal lattice.'
8. Define the term voids.
9. What type of stoichiometric defect is shown by (i) ZnS and (ii) CsCl?
[Hint. : (i) Frenkel defect (ii) Schottky defect]
- *10. If the formula of a compound is A_2B , which sites would be occupied by A ions?
[Hint. : Number of A ions is double to B ions, so ions will occupy tetrahedral voids]
11. What is the coordination number for
 - (a) an octahedral void
 - (b) a tetrahedral void.[Hint. : (a) 6; (b) 4]
- *12. How many octahedral voids are there in 1 mole of a compound having cubic closed packed structure? [Ans. : 1 mole]
13. Arrange simple cubic, bcc and fcc lattice in decreasing order of the fraction of the unoccupied space.
[Hint. : fcc < bcc < sc]
14. How much space is empty in a hexagonal closed packed solid?

15. An element crystallises separately both in hcp and ccp structure. Will the two structures have the same density? Justify your answer.

[Hint : Both crystal structures have same density because the percentage of occupied space is same.]

16. In NaCl crystal, Cl^- ions form the cubic close packing. What sites are occupied by Na^+ ions.

17. In Corundum, O^{2-} ions form hcp and Al^{3+} occupy two third of octahedral voids. Determine the formula of corundum. [Ans. : Al_2O_3]

18. Why is Frenkel defect not found in pure alkali metal halides?

19. Which point defect is observed in a crystal when a vacancy is created by an atom missing from a lattice site.

20. Define the term 'doping'.

21. Why does conductivity of silicon increase with the rise in temperature.

22. Name the crystal defect which lowers the density of an ionic crystal.

[Ans. : Schottky defect]

23. What makes the crystal of KCl sometimes appear violet?

[Hint : F-Centre]

24. Which point defect in ionic crystal does not alter the density of the relevant solid?

25. Name one solid in which both Frenkel and Schottky defects occur.

26. Which type of defects are known as thermodynamic defects?

[Ans. : Stoichiometric defects]

27. In a p-type semiconductor the current is said to move through holes. Explain.

28. Solid A is very hard, electrical insulator in solid as well as in molten state and melts at extremely high temperature. What type of solid is it?

[Hint : Covalent solid]

SA (I) TYPE QUESTIONS (2 - MARK QUESTIONS)

- List four distinctions between crystalline and amorphous solids with one example of each.
- Give suitable reason for the following—
 - Ionic solids are hard and brittle.
 - Copper is malleable and ductile.
- Define F-centre. Mention its one consequence.
- What is packing efficiency. Calculate the packing efficiency in body-centered cubic crystal.
- Explain :
 - List two differences between metallic and ionic crystals.
 - Sodium chloride is hard but sodium metal is soft.
- Account for the following :
 - Glass objects from ancient civilizations are found to become milky in appearance.
 - Window glass panes of old buildings are thicker at the bottom than at the top.
- Why is graphite soft lubricant and good conductor of electricity?
- What do you understand by the following types of stacking sequences :
 - AB AB
 - A B CABCWhat kind of lattices do these sequences lead to?
- Derive the formula for the density of a crystal whose length of the edge of the unit cell is known?

$$\left[\text{*Hint : } d = \frac{zm}{a^3 \times n_A} \right]$$

- Explain how much portion of an atom is located at (a) corner (b) body centre (c) face-centre and (d) edge centre of a cubic unit cell.
- *11. In a fcc arrangement of A and B atoms A are present at the corners of the unit cell and B are present at the face centres. If one atom of A is missing from its position at the corner, what is the formula of the compound?

[Ans. : A₇B₂₄]

- *12. A compound made up of elements 'A' and 'B' crystallises in a cubic close packed structure. Atoms A are present on the corners as well as face centres, whereas atoms B are present on the edge-centres as well as body centre. What is the formula of the compound? [Ans. AB]
13. Explain the terms :
- Intrinsic semiconductor
 - Extrinsic semiconductor.
14. Explain how vacancies are introduced in a solid NaCl crystal when divalent cations are added to it.
15. What is meant by non-stoichiometric defect? Ionic solids which have anionic vacancies due to metal excess defect develop colour. Explain with the help of suitable example.
16. Define the term '**point defects**'. Mention the main difference between stoichiometric and non-stoichiometric point defects.

THE SOLID STATE (2 - MARK QUESTIONS)

17. A compound M_pX_q has cubic close packing (ccp) arrangement of X. Its unit cell structure is shown below :

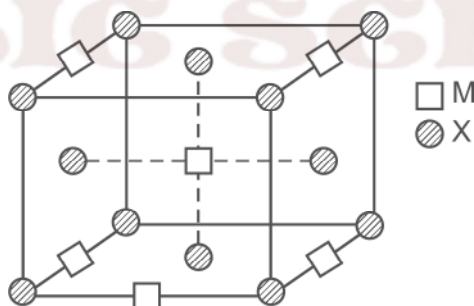

Determine the empirical formula of the compound. [Ans : MX_2]

18. The concentration of cation vacancies in NaCl crystal doped with $CdCl_2$ is found to be $6.02 \times 10^{16} \text{ mol}^{-1}$. What is the concentration of $CdCl_2$ added to it? [Ans : $10^{-5} \text{ mol\% CdCl}_2$]
19. Iron changes its crystal structure from body centred to cubic close packed structure when heated to 916°C . Calculate the ratio of the density of the BCC crystal to that of CCP crystal. Assume that the metallic radius of the atom does not change. [Ans : 1]

SA (II) TYPE QUESTIONS (3 - MARK QUESTIONS)

- Write the relationship between atomic radius (r) and edge length (a) of cubic unit cell for
 - Simple cubic unit cell
 - Body-centred cubic unit cell
 - Face-centred cubic unit cell

[*Hint: (a) $a = 2r$ (b) $a = \frac{4}{\sqrt{3}}r$ (c) $a = 2\sqrt{2}r$]
- Define a semiconductor? Describe the two main types of semiconductors when it is doped with
 - group 13 element,
 - group 15 element.
- Explain the following terms with one example each :
 - Ferrimagnetism
 - Antiferromagnetism
 - 13-15 compounds
- *4. Examine the defective crystal lattice given below and answer the following questions :

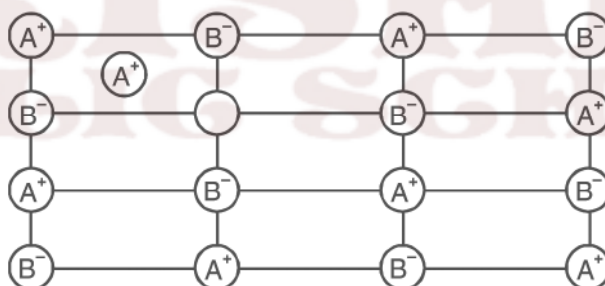

- Name the crystal defect present in ionic solid.
 - Out of AgCl and NaCl, which is most likely to show this type of defect and why?
 - Why this defect is also known as dislocation defect?
- Tungsten crystallizes in body centred cubic unit cell. If the edge of the unit cell is 316.5 pm, calculate the radius of tungsten atom?
 - Iron has a body centred cubic unit cell with a cell dimension of 286.65 pm. The density of iron is 7.874 g cm⁻³. Use this information to calculate Avogadro number.
(At. Mass of Fe = 55.845u).

NUMERICALS

1. Sodium crystallises in a bcc unit cell. What is the approximate number of unit cells in 4.6 g of sodium? Given that the atomic mass of sodium is 23 g mol⁻¹. [Ans. : 6.022 × 10²²]
- *2. In a crystalline solid anions 'C' are arranged in cubic close packing, cations 'A' occupy 50% of tetrahedral voids and cations 'B' occupy 50% of octahedral voids. What is the formula of the solid? [Ans. : A₂BC₂]
- *3. Magnetite, a magnetic oxide of iron used on recording tapes, crystallises with iron atoms occupying $\frac{1}{8}$ of the tetrahedral holes and $\frac{1}{2}$ of the octahedral holes in a closed packed array of oxides ions. What is the formula of magnetite? [Ans. : Fe₃O₄]
4. A metal crystallises into two cubic lattices fcc and bcc, whose edge length are 3.5Å and 3.0Å respectively. Calculate the ratio of the densities of fcc and bcc lattices.
5. An element of atomic mass 98.5 g mol⁻¹ occurs in fcc structure. If its unit cell edge length is 500 pm and its density is 5.22 g cm⁻³. Calculate the value of Avogadro constant. [Ans. : 6.03 × 10²³ mol⁻¹]
6. An element crystallises in a cubic close packed structure having a fcc unit cell of an edge 200 pm. Calculate the density if 200 g of this element contain 24 × 10²³ atoms. [Ans. : 41.6 g cm⁻³]
7. Analysis shows that a metal oxide has a empirical formula M_{0.96}O. Calculate the percentage of M²⁺ and M³⁺ ions in this crystal. [Ans. : M²⁺ = 91.7%, M³⁺ = 8.3%]
8. AgCl is doped with 10⁻² mol% of CdCl₂, find the concentration of cation vacancies. [Ans. : 10⁻⁴ mol]
9. A metallic element has a body centered cubic lattice. Edge length of unit cell is 2.88 × 10⁻⁸ cm. The density of the metal is 7.20 gcm⁻³. Calculate
 - (a) The volume of unit cell.
 - (b) Mass of unit cell.
 - (c) Number of atoms in 100 g of metal.[Ans. : (a) 2.39 × 10⁻²³ cm³ (b) 1.72 × 10⁻²² g, (c) 1.162 × 10²⁴ atoms]
10. Molybdenum has atomic mass 96 g mol⁻¹ with density 10.3 g/cm³. The

edge length of unit cell is 314 pm. Determine lattice structure whether simple cubic, bcc or fcc.

(Given $N_A = 6.022 \times 10^{23} \text{ mol}^{-1}$) [Ans. : $Z = 2$, bcc type]

- *13. The density of copper metal is 8.95 g cm^{-3} . If the radius of copper atom is 127 pm, is the copper unit cell a simple cubic, a body-centred cubic or a face centred cubic structure?

(Given at. mass of Cu = 63.54 g mol^{-1} and $N_A = 6.02 \times 10^{23} \text{ mol}^{-1}$)
[Ans. : $Z = 4$, fcc type]

[Hint : $d = \frac{ZM}{a^3 \times N_A}$ calculate Z/a^3 by putting the values given in the question.

Calculate packing efficiency by $\frac{z \times \frac{4}{3} \pi r^3 \times 100}{a^3}$ using value of

Z/a^3 , which is 74%. This shows that $Z = 4$

14. The well known mineral fluorite is chemically calcium fluoride. It is known that in one unit cell of this mineral there are 4 Ca^{2+} ions and 8 F^- ions and that Ca^{2+} ions are arranged in a fcc lattice. The F^- ions fill all the tetrahedral holes in the fcc lattice of Ca^{2+} ions. The edge of the unit cell is $5.46 \times 10^{-8} \text{ cm}$ in length. The density of the solid is 3.18 g cm^{-3} . Use this information to calculate Avogadro's number (Molar mass of $\text{CaF}_2 = 78.08 \text{ g mol}^{-1}$)

[Ans. : $6.02 \times 10^{23} \text{ mol}^{-1}$]

Unit - 2

SOLUTIONS

VSA QUESTIONS (1 - MARK QUESTIONS)

1. Give an example of 'liquid in solid' type solution.
2. Which type of solid solution will result by mixing two solid components with large difference in the sizes of their molecules?
3. What is meant by semimolar and decimolar solutions? [Ans.: $\frac{M}{2}$, $\frac{M}{10}$]
4. What will be the mole fraction of water in C_2H_5OH solution containing equal number of moles of water and C_2H_5OH ? [Ans. : 0.5]
5. Which of the following is a dimensionless quantity : molarity, molality or mole fraction? [Ans. : mole fraction]
6. 10 g glucose is dissolved in 400 g. of solution. Calculate percentage concentration of the solution. [Ans. : 2.5% w/w]
7. Gases tend to be less soluble in liquids as the temperature is raised. Why?
8. State the conditions which must be satisfied if an ideal solution is to be formed.
9. A mixture of chlorobenzene and bromobenzene forms nearly ideal solution but a mixture of chloroform and acetone does not. Why?
10. How is the concentration of a solute present in trace amount in a solution expressed?
- *12. N_2 and O_2 gases have K_H values 76.48 kbar and 34.86 kbar respectively at 293 K temperature. Which one of these will have more solubility in water?

- *13. Under what condition molality and molarity of a solution are identical. Explain with suitable reason.
- *14. Addition of H_2I_2 to KI (aq.) shows decrease in vapour pressure. Why?
15. What will happen to the boiling point of the solution formed on mixing two miscible liquids showing negative deviation from Raoult's law?
16. Liquid 'Y' has higher vapour pressure than liquid 'X', which of them will have higher boiling point?
17. When 50 mL of ethanol and 50 mL of water are mixed, predict whether the volume of the solution is equal to, greater than or less than 100 mL. Justify.
18. Which type of deviation is shown by the solution formed by mixing cyclohexane and ethanol?
19. A and B liquids on mixing produce a warm solution. Which type of deviation from Raoult's law is there?
20. Define cryoscopic constant (molal freezing point depression constant.)
21. Mention the unit of ebullioscopic constant (molal boiling point elevation constant.)
22. If k_f for water is $1.86 \text{ K kg mol}^{-1}$, what is the freezing point of 0.1 molal solution of a substance which undergoes no dissociation or association of solute?
- [Hint : $\Delta T_f = iK_f \cdot m$]
24. What is reverse osmosis? Give one large scale use of it.
- *25. What is the maximum value of van't Hoff factor (i) for $Na_2SO_4 \cdot 10H_2O$?
[Ans. : $i = 3$]
26. What is the value of van't Hoff factor (i) if solute molecules undergo dimerisation.
[Ans. : $i = 0.5$]
27. Under what condition is van't Hoff factor less than one?
[Ans. : Association]
- *28. The Phase Diagram for pure solvent and the solution containing nonvolatile solute are recorded below. The quantity indicated by 'X' in the figure is known as :
[Ans. : ΔT_b]

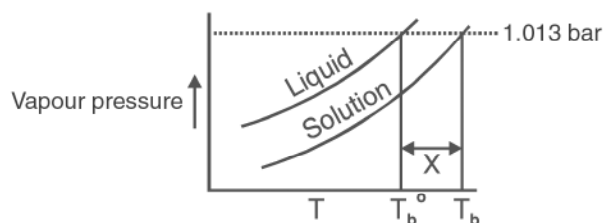

- *29. AgNO_3 on reaction with NaCl in aqueous solution gives white precipitate. If the two solutions are separated by a semi-permeable membrane, will there be appearance of a white ppt. in the side 'X' due to osmosis?

0.1 M AgNO_3 X	S P M	0.01 M NaCl Y
-------------------------------	-------------	------------------------------

[Ans. : No ppt, because only solvent particles moves through SPM]

SA (I) - TYPE QUESTIONS (2 - MARK QUESTIONS)

- Explain the following :
 - Solubility of a solid in a liquid involves dynamic equilibrium.
 - Ionic compounds are soluble in water but are insoluble in nonpolar solvents.
- Give two examples each of a solution :
 - showing positive deviation from Raoult's Law.
 - showing negative deviation from Raoult's Law.
- Draw vapour pressure vs composition (in terms of mole fraction) diagram for an ideal solution.
- Define azeotropes with one example of each type.
- Draw the total vapour pressure vs. mol fraction diagram for a binary solution exhibiting non-ideal behaviour with negative deviation.
- The vapour pressure curve for three solutions having the same non-volatile solute in the same solvent are shown. The curves are parallel to each other and do not intersect. What is the correct order of the concentrations of the solutions. [Hint. : $A < B < C$]

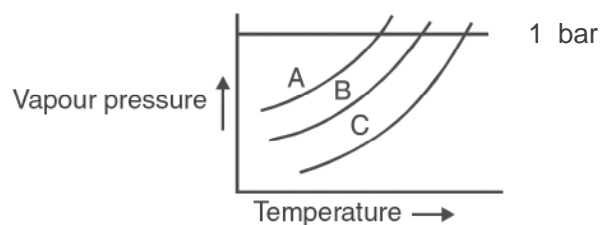

7. Show that the relative lowering of vapour pressure of a solvent is a colligative property.
8. Benzene and toluene form a nearly ideal solution. At a certain temperature, calculate the vapour pressure of solution containing equal moles of the two substances.
[Given : $P^{\circ}_{\text{Benzene}} = 150 \text{ mm of Hg}$, $P^{\circ}_{\text{Toluene}} = 55 \text{ mm of Hg}$]
9. What is meant by abnormal molecular mass? Illustrate it with suitable examples.
- *10. When 1 mole of NaCl is added to 1 litre water, the boiling point increases? When 1 mole of CH_3OH is added to 1 litre water, the boiling point decreases? Suggest reasons.
11. Can we separate water completely from HNO_3 solution by vapourisation? Justify your answer.
- *12. 1 gram each of two solutes 'A' and 'B' (molar mass of A > molar mass of B) are dissolved separately in 100 g each of the same solvent. Which solute will show greater elevation in boiling point and Why?

Solution

2 - MARK QUESTIONS

13. Examine the following illustrations and answer the following questions

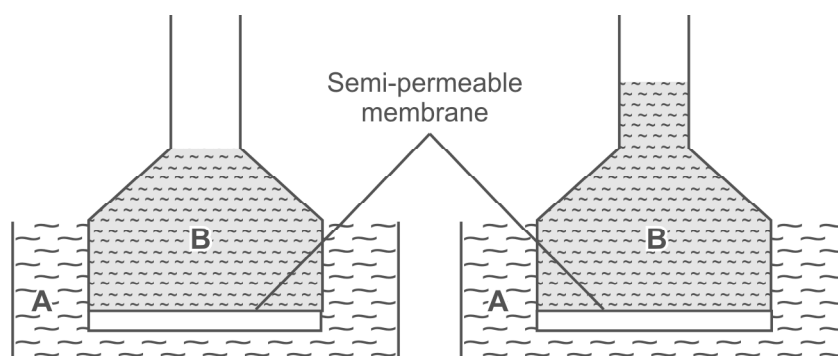

- (a) Identify the liquid A and liquid B (pure water or sugar solution)
- (b) Name the phenomenon involved in this experiment so that the level of liquid in this the funnel has risen after some time.
14. How relative lowering in vapour pressure is related with depression in freezing point and elevation in boiling point?

SA (II) TYPE QUESTIONS (3 - MARK QUESTIONS)

1. (a) State Henry's Law.
- (b) If O_2 is bubbled through water at 393 K, how many millimoles of O_2 gas would be dissolved in 1L of water? Assume that O_2 exerts a pressure of 0.95 bar.
- (Given K_H for $O_2 = 46.82$ bar at 393K).
2. Given reason for the following :-
- (a) Aquatic species are more comfortable in cold waters than in warm waters.
- (b) To avoid bends scuba divers use air diluted with helium.
- (c) Cold drinks bottles are sealed under high pressure of CO_2 .
3. Why should a solution of a non-volatile and non-eletrolyte solute boil at a higher temperature? Explain with the help of a diagram. Derive the relationship between molar mass and elevation in boiling point.
4. Account for the following :-
- (a) $CaCl_2$ is used to clear snow from roads in hill stations.
- (b) Ethylene glycol is used as antifreeze solution in radiators of vehicles in cold countries.
- (c) The freezing point depression of 0.01 m NaCl is nearly twice that of 0.01 m glucose solution.
5. Why do colligative properties of solution of a given concentration are found to give abnormal molecular weight of solute. Explain with the help of suitable examples.
6. Give reasons for the following :-
- (a) RBC swell up and finally burst when placed in 0.1% NaCl solution.
- (b) When fruits and vegetables that have been dried are placed in water, they slowly swell and return to original form.

- (c) A person suffering from high blood pressure is advised to take less amount of table salt.
- *7. Glycerine, ethylene glycol and methanol are sold at the same price per kg. Which would be cheaper for preparing an antifreeze solution for the radiator of an automobile? **[Ans. : Methanol]**
- *8. Determine the correct order of the property mentioned against them :
- (a) 10% glucose (p_1), 10% urea (p_2), 10% sucrose (p_3) **[Osmotic pressure]**
- (b) 0.1 m NaCl, 0.1 m urea, 0.1 m $MgCl_2$ **[Elevation in b.pt.]**
- (c) 0.1 m $CaCl_2$, 0.1 m sucrose, 0.1 m NaCl **[Depression in f.pt.]**
9. For a dilute solution containing 2.5 g of a non-volatile non-electrolyte solute in 100 g of water, the elevation in boiling point at 1 atm pressure is $2^\circ C$. Assuming concentration of solute is much lower than the concentration of solvent, determine the vapour pressure (mm of Hg) of the solution.

[Given : K_b for water = 0.76 kg mol^{-1}] [Ans.: 724 mm of Hg]

[Hind : $\Delta T_b = K_b \cdot m \Rightarrow 0.76 \times \frac{2.5}{M_b} \times \frac{1000}{100} = 2k$

$$M_b = 9.5 \text{ g mol}^{-1}$$

$$\frac{p_A^\circ - p_A}{p_A^\circ} = \frac{25}{95} \times \frac{18}{100}$$

$$\frac{760 - p_A}{760} = \frac{25}{95} \times \frac{18}{100} \Rightarrow p_A = 724 \text{ mm of Hg]$$

10. 15.0 g of an unknown molecular substance was dissolved in 450 g of water. The resulting solution was found to freeze at $-0.34^\circ C$. What is the molar mass of this substance. (K_f for water = $1.86 \text{ K kg mol}^{-1}$).

LONG ANSWER TYPE QUESTIONS (5 MARKS)

1. (a) What are ideal solutions? Write two examples.
- (b) Calculate the osmotic pressure in pascals exerted by a solution prepared by dissolving 1.0g of polymer of molar mass 185000 in 450 mL of water at $37^\circ C$.

2. (a) Describe a method of determining molar mass of a non-volatile solute from vapour pressure lowering.
- (b) How much urea (mol. mass 60 g mol^{-1}) must be dissolved in 50g of water so that the vapour pressure at the room temperature is reduced by 25%? Also calculate the molality of the solution obtained.
[Ans. : 55.55 g and 18.5 m]
3. (a) Why is the freezing point depression considered as a colligative property?
- (b) The cryoscopic constant of water is $1.86 \text{ K kg mol}^{-1}$. Comment on this statement.
- (c) Calculate the amount of ice that will separate out on cooling solution containing 50 g of ethylene glycol in 200 g H_2O to -9.3°C . (K_f for water = $1.86 \text{ K kg mol}^{-1}$)
[Ans. : 38.71g]
4. (a) Define osmotic pressure.
- (b) Why osmotic pressure is preferred over other colligative properties for the determination of molecular masses of macromolecules?
- (c) What is the molar concentration of particles in human blood if the osmotic pressure is 7.2 atm at normal body temperature of 37°C ?
[Ans. : 0.283 M]

NUMERICAL PROBLEMS

1. Calculate the mass percentage of benzene (C_6H_6) and carbon tetrachloride (CCl_4), if 22g of benzene is dissolved in 122g of carbon tetrachloride.
[Ans. : $\text{C}_6\text{H}_6 = 15.3\%$, $\text{CCl}_4 = 84.7\%$]
2. Calculate the molarity of a solution prepared by mixing 500 mL of 2.5 M urea solution and 500 mL of 2M urea solution.
[Ans. : 2.25 m]
[Hint : $M = \frac{M_1 V_1 + M_2 V_2}{V_1 + V_2}$]
3. The mole fraction of CH_3OH in an aqueous solution is 0.02 and density of solution 0.994 g cm^{-3} . Determine the molality and molarity.
[Ans. : 1.13m, 1.08m]
4. 200 mL of calcium chloride solution contains 3.011×10^{22} Cl^- ions. Calculate the molarity of the solution. Assume that calcium chloride is completely ionized.
[Ans. : 0.125 M]

5. 6×10^{-3} g oxygen is dissolved per kg of sea water. Calculate the ppm of oxygen in sea water. [Ans. : 6 ppm]
6. The solubility of oxygen in water is 1.35×10^{-3} mol L⁻¹ at 20°C and 1 atm pressure. Calculate the concentration of oxygen at 20°C and 0.2 atm pressure. [Ans. : 2.7×10^{-4} mol L⁻¹]
7. Two liquids X and Y on mixing form an ideal solution. The vapour pressure of the solution containing 2 mol of X and 1 mol of Y is 550 mm Hg. But when 4 mol of X and 1 mole of Y are mixed, the vapour pressure of solution thus formed is 560 mm Hg. What will be the vapour pressure of pure X and pure Y at this temperature? [Ans. : X = 600 mm Hg; Y = 400 mm Hg]
8. An aqueous solution containing 3.12 g of barium chloride in 250 g of water is found to be boil at 100.0832°C. Calculate the degree of dissociation of barium chloride.
[Given molar mass BaCl₂ = 208 g mol⁻¹, K_b for water = 0.52 K/m]
[Ans. : 83.3%]
9. The degree of dissociation of Ca(NO₃)₂ in a dilute aqueous solution, containing 7.0 g of salt per 100 g of water at 100°C is 70%. If the vapour pressure of water at 100°C is 760 mm of Hg, calculate the vapour pressure of the solution. [Ans. : 745.3 mm of Hg]
10. 2g of C₆H₅COOH dissolved in 25g of benzene shows depression in freezing point equal to 1.62K. Molar freezing point depression constant for benzene is 4.9 K kg mol⁻¹. What is the percentage association of acid if it forms a dimer in solution? [Ans. : 99.2%]
11. Calculate the amount of NaCl which must added to one kg of water so that the freezing point is depressed by 3K. Given K_f = 1.86 K kg mol⁻¹, Atomic mass : Na = 23, Cl = 35.5). [Ans. : 0.81 mol NaCl]
12. Three molecules of a solute (A) associate in benzene to form species A₃. Calculate the freezing point of 0.25 molal solution. The degree of association of solute A is found to be 0.8. The freezing point of benzene is 5.5°C and its K_f value is 5.13 K/m. [Ans. : 4.9°C]
13. A 5% solution of sucrose (C₁₂H₂₂O₁₁) is isotonic with 0.877% solution of urea. NH₂CONH₂) Calculate the molecular mass of urea.[Ans. : 59.99 g mol⁻¹]
14. Osmotic pressure of a 0.0103 molar solution of an electrolyte was found to be 0.75 atm at 27°C. Calculate Van't Hoff factor. [Ans. : $i = 3$]

- *15. The maximum allowable level of nitrates in drinking water is 45 mg nitrate ions/dm³. Express this level in ppm? [Ans. : 45 ppm]
16. 75.2 g of Phenol (C₆H₅OH) is dissolved in 1 kg solvent of K_f = 14 K m⁻¹, if the depression in freezing point is 7K, then find the % of phenol that dimerises. [Ans. : 75%]
- *17. An aqueous solution of glucose boils at 100.01°C. The molal boiling point elevation constant for water is 0.5 K kg mol⁻¹. What is the number of glucose molecule in the solution containing 100 g of water. [Ans. : 1.2 × 10²¹ molecules]
18. A bottle of commercial H₂SO₄ [density = 1.787 g/mL] is labelled as 86% by mass.
- (a) What is the molarity of the acid?
- (b) What volume of the acid has to be used to make 1 litre 0.2 M H₂SO₄?
- (c) What is the molality of the acid? [Ans. : 15.7 M, 12.74 mL, 62.86 m]
19. A solution containing 30g of non-volatile solute exactly in 90g of water has a vapour pressure of 2.8 kPa at 298 K. Further, 18 g of water is then added to the solution and the new vapour pressure becomes 2.9 kPa at 298 K. Calculate :
- (i) molar mass of the solute
- (ii) Vapour pressure of water at 298 K. [Ans. : 34 g mol⁻¹, 3.4 kPa]
20. The vapour pressure of pure liquids A and B are 450 and 750 mm Hg respectively, at 350K. Find out the composition of the liquid mixture if total vapour pressure is 600 mm Hg. Also find the composition of the vapour phase. [Ans. : X_A = 0.4, X_B = 0.6, Y_A = 0.3, Y_B = 0.7]
21. An aqueous solution of 2% non-volatile solute exerts a pressure of 1.004 bar at the normal boiling point of the solvent. What is the molar mass of the solute? [Ans. : 41.35 g mol⁻¹]

Unit - 3

ELECTROCHEMISTRY

VSA QUESTIONS (1 - MARK QUESTIONS)

1. What is a galvanic cell?
2. Give the cell representation for Daniell Cell.
3. Mention the purpose of salt-bridge placed between two half-cells of a galvanic cell?
4. Give the condition for Daniell Cell in which there is no flow of electrons or current.
5. How is electrode potential different from cell potential?
6. Can you store zinc sulphate solution in a copper container? Give suitable reason. ($E^{\ominus}\text{Zn}^{2+}/\text{Zn} = - 0.76\text{V}$, $E^{\ominus}\text{Cu}^{2+}/\text{Cu} = 0.34\text{V}$)
7. How does electrochemical series help us in predicting whether a redox reaction is feasible or not?
8. Write Nernst equation for the electrode reaction. $\text{M}^{n+}_{(\text{aq})} + n\text{e}^{-} \rightarrow \text{M}_{(\text{s})}$ at 298 K and 1 bar pressure.
10. List the two factors that influence the value of cell potential of a galvanic cell.
11. How is equilibrium constant of a reaction related to standard cell potential?
12. Write the relation between $E^{\ominus}\text{cell}$ and equilibrium constant (K) of cell reaction.
13. Define cell constant. Write the SI unit of cell constant.
14. How does specific conductance or conductivity of electrolytic solution vary with temperature?
15. What is the SI unit of (i) Conductance; (ii) Conductivity.
16. Represent a concentration cell with a suitable example.

17. State one difference between a primary battery and secondary battery.
- *18. Galvanized iron does not corrode even if the coating of zinc is broken. Explain why?

(Given : $E^\ominus \text{Fe}^{2+}/\text{Fe} = -0.44\text{V}$; $E^\ominus \text{Zn}^{2+}/\text{Zn} = -0.76\text{V}$)

19. Write the unit of Faraday constant.
- *20. Write the name of a chemical substance which is used to prevent corrosion.

[Ans. : Bisphenol]

21. Show the direction of flow of electrons in the following cell :



22. Rusting of iron becomes quicker in saline water?
- *23. Two metals A and B have reduction potential values of -0.25V and 0.80V respectively. Which of these will liberate hydrogen gas from dilute H_2SO_4 ?
24. Express the relation between conductivity and molar conductivity.
25. Name the cell which was used in Apollo space programme.
26. How many faradays are required to oxidise 1 mole of H_2O to O_2 .

[Ans. : 2F]

SA (I) TYPE QUESTIONS (2 - MARK QUESTIONS)

1. List two points of difference between metallic conductance and electrolytic conductance.
2. List two points of difference between electrochemical cell and electrolytic cell.
3. List two factors which affect the conductivity of ionic solutions.
4. A conventional method of representing a Daniel cell is :
 $\text{Zn (s)} \mid \text{Zn}^{2+} \text{ (1M)} \parallel \text{Cu}^{2+} \text{ (1M)} \mid \text{Cu (s)}$.
- (i) Draw a diagram of the cell and mark anode and cathode as current is drawn from the cell.
- (ii) Write the reactions taking place at the cathode and the anode during the operation of Daniel cell.
- *5. Suggest a method to determine the Λ^\ominus_m value of water.

6. Write the cell reaction which occur in the lead storage battery (a) when the battery is in use (b) when the battery is on charging.
7. Why absolute value of electrode potential cannot be determined?
8. Account for the fact that when chlorine is passed through a fluoride solution, no reaction takes place. (Given $E^\theta_{F_2/2F^-} = 2.87V$; $E^\theta_{Cl_2/2Cl^-} = 1.36V$)
9. Copper does not dissolve in HCl (aq) but dissolves in HNO_3 (aq) producing Cu^{2+} ions. Explain the difference in behaviour.

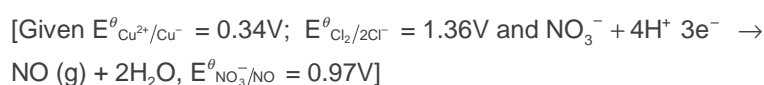

10. Explain the following observations :
- (a) The product of electrolysis of molten NaCl are sodium metal and chlorine gas.
- (b) The product of electrolysis of aqueous sodium chloride solution are NaOH, Cl_2 and H_2 .
11. What are fuel cells? Describe the principle and overall reaction involved in the working of hydrogen–oxygen fuel cell or $CH_3OH - O_2$ fuel cell.
12. Explain the meaning of the terms
- (a) Ionic mobility. (b) Overvoltage.
- *13. Some standard reduction potential are as given below :

Half Cell	E^θ Value
F_2/F^-	2.9V
Ag^+/Ag	0.8V
Cu^+/Cu	0.5V
Fe^{2+}/Fe	-0.4V
Na^+/Na	-2.7V
K^+/K	-2.9V

- (a) Arrange oxidising agents in order of increasing strength.
- (b) Which of these oxidising agents will oxidise Cu to Cu^+ under standard conditions?

14. Account for the following observations :

- (a) In a dry cell, the build up of ammonia around the carbon cathode should disrupt the electric current, but in practice this does not happen.
- (b) Ordinary dry cells are not rechargeable.

*15. The following figure shows two electrolytic cells connected in series.

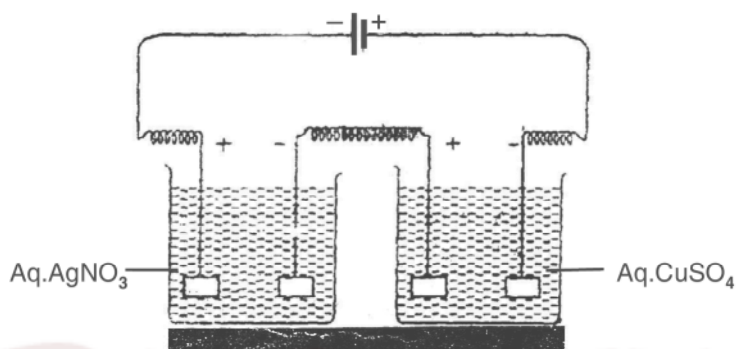

- (a) How much electricity is required for the reduction of 1 mole of Ag⁺ ions to Ag?
- (b) If three faradays of electricity is passed through these cells, what is the ratio of cations Ag⁺ and Cu²⁺ deposited on cathodes?

[Ans. : (a) 1F, (b) 2:1]

16. You are acquainted with the construction and working of a lead storage battery. Give the plausible reasons for these facts.

- (a) There is only a single compartment unlike other electrochemical cells which have two compartments
- (b) Addition of water is necessary from time to time for maintenance

SA (II) TYPE QUESTIONS (3 - MARK QUESTIONS)

1. Using the standard electrode potential, predict the reaction, if any that occurs between the following :

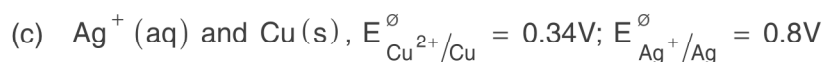
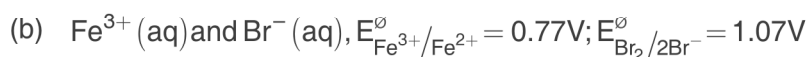
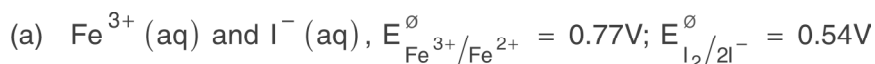

2. State the relationship amongst cell constant of a cell, resistance of the solution in the cell and conductivity of the solution. How is molar conductivity of a solute related to conductivity of its solution?

3. Describe the composition of anode and cathode in a mercury cell. Write the electrode reactions for this cell. Why does it provide constant voltage throughout its life?

4. Give reasons for :

(a) For a weak electrolyte, its molar conductivity of dilute solution increases as the concentration of solution is decreased.

(b) Molar conductivity of a strong electrolyte like KCl decreases almost linearly while increasing concentration?

(c) It is not easy to determine Λ°_m of a weak electrolyte by extrapolation of \sqrt{c} vs Λ_m curves?

5. (a) Write the mechanism of the corrosion of metals.

(b) How is underground iron pipe protected from corrosion?

6. Formulate the galvanic cell in which the following reaction takes place :

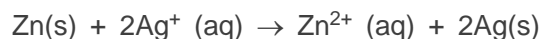

State

(a) Which one of its electrodes is negatively charged?

(b) The reaction taking place at each of its electrode.

(c) The direction of current within this cell.

*7. The standard reduction potentials are as given below :-

Half Cell	E° Value
Zn (OH) ₂ /Zn	- 1.245 V
Mg (OH) ₂ /Mg	- 2.690 V
Fe (OH) ₂ /Fe	- 0.877 V
Fe (OH) ₃ /Fe	- 2.30 V

Under standard conditions :

- Which is the strongest reducing agent?
- Which reducing agent could reduce Zn(OH)₂ to Zn?
- Which reducing agent could reduce Fe(OH)₂ to Fe?

LONG ANSWER TYPE QUESTIONS (5 MARKS)

- Explain with example the terms weak and strong electrolytes.
 - Calculate the emf of the cell

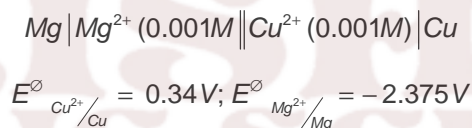

[Ans. : 2.651 V]

- Explain Kohlrausch law of independent migration of ions. Mention two applications of this law.
 - The conductivity of 0.001M CH₃COOH is $4.95 \times 10^{-5} \text{ Scm}^{-1}$. Calculate its dissociation constant. Given for acetic acid Λ_m° is $390.5 \text{ S cm}^2 \text{ mol}^{-1}$.
[Ans. : = 0.126]
- Define molar conductivity. Draw the plots showing the variation of molar conductivity for strong and weak electrolyte with square root of concentration.
 - Resistance of a solution (A) is 50 ohm and that of solution (B) is 100 ohm, both solutions being taken in the same conductivity cell, if equal volumes of solutions (A) and (B) are mixed, what will be the resistance of the mixture, using the same cell? Assume that there is no increase in the degree of dissociation of (A) and (B) on mixing.
[Ans. : 66.66 ohm]

[Hint. : k = Conductivity, y = Cell constant]

$$k_1 = \frac{1}{50} y, k_2 = \frac{1}{100} y : \text{ and specific conductance of mixture is given by}$$
$$= \frac{k_1 + k_2}{2}$$

$$\frac{k_1 + k_2}{2} = \frac{1}{R} \times y, \frac{1}{2} \left[\frac{y}{50} + \frac{y}{100} \right] = \frac{1}{R} \times y \Rightarrow R = 66.66 \text{ ohm}$$

4. (a) State Faraday's first and second laws of electrolysis.
(b) Silver is deposited on a metallic vessel of surface area 800 cm^2 by passing current of 0.2 ampere for 3 hours. Calculate the thickness of silver deposited.

(Density of silver = 10.47 g cm^{-3} , Molar atomic mass of silver =

$107.924 \text{ g mol}^{-1}$) [Ans. : $2.9 \times 10^{-4} \text{ cm}$]

5. (a) Draw the diagram of standard hydrogen electrode. Write the electrode reaction.
(b) Calculate the equilibrium constant for the reaction :



Given $E^\ominus_{\text{Ce}^{4+}/\text{Ce}^{3+}} = 1.44 \text{ V}; E^\ominus_{\text{Fe}^{3+}/\text{Fe}^{2+}} = 0.68 \text{ V}$

[Ans. : 7.6×10^{12}]

NUMERICAL PROBLEMS

- *1. The emf of the following cells are:

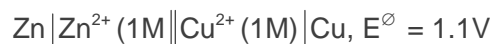

Calculate emf of the cell :



2. For concentration cell



- (a) Calculate the cell potential.
(b) Will the cell generate emf when concentration becomes equal?

[Ans. : (a) 0.295V, (b) No.]

3. Calculate the equilibrium constant for the reaction at 25°C.

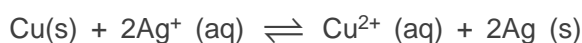

The standard cell potential for the reaction at 25°C is 0.46V.

[Given $R = 8.314 \text{ JK}^{-1} \text{ mol}^{-1}$]

[Ans. : 4.0×10^{15}]

4. Calculate ΔG° for the reaction.

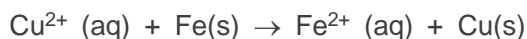

$$E^\circ_{\text{Cu}^{2+}/\text{Cu}} = +0.34\text{V}; E^\circ_{\text{Fe}^{2+}/\text{Fe}} = -0.44\text{V}$$

[Ans. : -150, 540 kJ]

6. Write the Nernst equation and calculate the emf of the following cell at 298K.

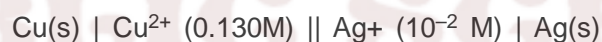

$$\text{Given } E^\circ_{\text{Cu}^{2+}/\text{Cu}} = +0.34\text{V}; E^\circ_{\text{Ag}^+/\text{Ag}} = +0.80\text{V}$$

[Ans. : 0.37V]

7. A zinc rod is dipped in 0.1M solution of ZnSO_4 . The salt is 95% dissociated at this dilution at 298K. Calculate the electrode potential

$$\left(E^\circ_{\text{Zn}^{2+}/\text{Zn}} = -0.76\text{V} \right).$$

[Ans. : -0.7902V]

8. For the electrode $\text{Pt, H}_2 (1 \text{ atm}) | \text{H}^+_{(\text{aq})} (x\text{M})$, the reduction electrode potential at 25°C is - 0.34V. Write the electrode reaction and calculate the value of x. and the pH of solution.

[Ans. : $x = 1.807 \times 10^{-6}$, pH = 5.743]

9. For what concentration of $\text{Ag}^+ (\text{aq})$ will the emf of the given cell be zero at 25°C if concentration of $\text{Cu}^{2+} (\text{aq})$ is 0.1M?

Given $E^{\ominus}_{\text{Ag}^+/\text{Ag}} = 0.80\text{V}$; $E^{\ominus}_{\text{Cu}^{2+}/\text{Cu}} = +0.34\text{V}$.

Cell : $\text{Cu (s)} \mid \text{Cu}^{2+} (\text{aq}) \parallel \text{Ag}^+ (\text{aq}) \mid \text{Ag (s)}$ [Ans. : 5.3×10^{-9}]

10. Zinc granules are added in excess to 500 mL of 1.0 M nickel nitrate solution at 25°C until the equilibrium is reached. If the standard reduction potential of $\text{Zn}^{2+} \mid \text{Zn}$ and $\text{Ni}^{2+} \mid \text{Ni}$ are -0.75V and -0.24V respectively, find out the concentration of Ni^{2+} in solution at equilibrium.

[Ans. : $5.88 \times 10^{-18}\text{M}$]

11. The molar conductivity of 0.1M CH_3COOH solution is $4.6\text{ S cm}^2 \text{ mol}^{-1}$. Calculate the conductivity and resistivity of the solution.

[Ans. : $.00046\text{ S cm}^{-1}$, $2174\ \Omega \text{ cm}$]

12. The molar conductivities of NH_4^+ ion and Cl^- ion are $73.5\text{ S cm}^2 \text{ mol}^{-1}$ and $76.255\text{ S cm}^2 \text{ mol}^{-1}$ respectively. The specific conductivity of 0.1 M NH_4Cl is $1.288 \times 10^{-2}\text{ S cm}^{-1}$. Calculate the dissociation constant of NH_4Cl .

[Ans. : 7.396×10^{-2}]

13. Molar conductivity at infinite dilution for NH_4Cl , NaOH and NaCl solution at 298K are respectively 129.8, 218.4 and $108.9\text{ S cm}^2 \text{ mol}^{-1}$ and m for 10^{-2} M solution of NH_4OH is $9.33\text{ S cm}^2 \text{ mol}^{-1}$. Calculate the degree of dissociation of NH_4OH .

[Ans. : 0.039]

14. Write the Nernst equation and emf of the following cell at 298 K; $\text{Pt (s)} \mid \text{Br}_2 (\text{l}) \mid \text{Br}^- (0.010\text{M}) \parallel \text{H}^+ (0.030\text{M}) \mid \text{H}_2 (\text{g}) (0.9\text{ bar}) \mid \text{Pt (s)}$. $E^{\ominus}_{\text{Br}_2/\text{Br}^-/\text{Pt}} = 1.09\text{V}$.

[Ans. : -1.297V]

15. In the button cells widely used in watches and other devices, the following reaction takes place :

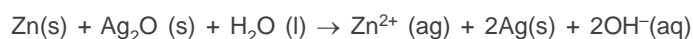

Determine $\Delta_r G^{\ominus}$ and E^{\ominus} for the reaction.

Given $E^{\ominus}_{\text{Zn}^{2+}/\text{Zn}} = -0.76\text{V}$; $E^{\ominus}_{\text{Ag}^+/\text{Ag}} = 0.8\text{V}$

[Ans.: -301.08 kJ / mol. , $E^{\ominus}_{\text{cell}} = 1.56\text{V}$]

Unit - 4

CHEMICAL KINETICS

VSA QUESTIONS (1 - MARK QUESTIONS)

1. Define the term 'rate of reaction'.
2. Mention the units of rate of reaction.
3. Express the rate of reaction in terms of $\text{Br}^- (\text{aq})$ as reactant and $\text{Br}_2 (\text{aq})$ as product for the reaction :

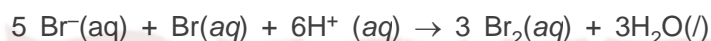

4. For a chemical reaction represented by $\text{R} \rightarrow \text{P}$ the rate of reaction is denoted by

$$\frac{-\Delta[\text{R}]}{\Delta t} \text{ or } \frac{+\Delta[\text{P}]}{\Delta t}$$

Why a positive sign (+) is placed before $\frac{\Delta[\text{P}]}{\Delta t}$ and negative sign (-)

before $\frac{\Delta[\text{R}]}{\Delta t}$?

5. Express the rate of reaction in terms of disappearance of hydrogen and appearance of ammonia in the given reaction.



6. Why rate of reaction does not remain constant throughout?
7. Write the unit of first order rate constant of a gaseous reaction if the partial pressure of gaseous reactant is given in bar.
8. For a zero order reaction :

$\text{R} \rightarrow \text{P}$, the change in concentration of reactant w.r.t. time is shown by following graph.

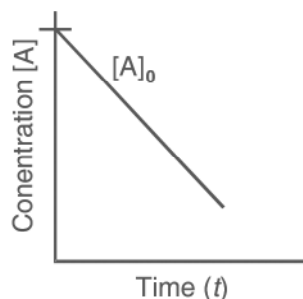

9. What will be the order of reaction, if the rate of reaction does not depend on the concentration of any of the reactant.

10. For the elementary step of a chemical reaction :

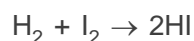

rate of reaction $\propto [\text{H}_2] [\text{I}_2]$

What is the (i) molecularity and (ii) order of the reaction.

[Ans. : (i) 2 (ii) 1]

11. For a chemical reaction $\text{A} \rightarrow \text{B}$. The rate of the reaction is given as $\text{Rate} = k [\text{A}]^n$, the rate of the above reaction quadruples when the concentration of A is doubled. What is the value of n? [Ans. : n = 2]

12. Mention one example of zero order reaction.

13. What is the value of the order of reaction of radioactive decay?

[Ans. : First order]

*14. Express the relation between the half life period of a reactant and initial concentration for a reaction of n^{th} order.

$$[\text{Ans. : } t_{1/2} \propto \frac{1}{[\text{A}]_0^{n-1}}$$

*15. A reaction is 50% complete in 2 hours and 75% complete in 4 hours. What is the order of reaction? **Ans** : [First order]

16. Suggest an appropriate reason for the observation : "On increasing temperature of the reacting system by 10 degrees, the rate of reaction almost doubles or even sometimes becomes five folds."

*17. For a chemical reaction, activation energy is zero and at 300K rate constant is $5.9 \times 10^{-5} \text{ s}^{-1}$, what will be the rate constant at 400K?

[Ans. : $5.9 \times 10^{-5} \text{ s}^{-1}$]

- *18. Two reactions occurring at the same temperature have identical values of E_a . Does this ensure that also they will have the same rate constant? Explain.

[Hint : Rate depends on the nature and concentrations of reactants and also pre-exponential factor.]

19. The rate constant of a reaction is given by the expression $k = Ae^{-E_a/RT}$. Which factor in this expression should register a decrease so that the reaction proceeds rapidly?
20. For a chemical reaction rate constant $k = 5.3 \times 10^{-4} \text{ mol L}^{-1} \text{ s}^{-1}$, what will be the order of reaction? [Ans. : Zero order]
21. Write the rate law and order for the following reaction :



[Ans. : Rate = $k [AB_2] [C_2]$; Order = $1 + 1 = 2$]

SA (I) TYPE QUESTIONS (2 - MARKS QUESTIONS)

22. List four factors which affect the rate of a chemical reaction. State how each of these factors changes the reaction rate.
23. Differentiate between
- (a) Average rate and instantaneous rate of a chemical reaction.
- (b) Rate of a reaction and specific rate of reaction, i.e., rate constant.
24. The rate law for the reaction : $A + B \rightarrow P$ is given by

$$\text{Rate} = k [A]^n [B]^m$$

On doubling the concentration of A and reducing the concentration of B to half of its original concentration, calculate the ratio of the new rate to the previous rate of reaction. [Ans. : 2^{n-m}]

$$\left[\text{Hint : } \frac{\text{New rate}}{\text{Previous rate}} = \frac{k [2A]^n \left[\frac{B}{2}\right]^m}{k [A]^n [B]^m} \right]$$

25. For the reaction in a closed vessel :

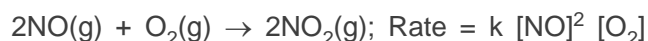

If the volume of the reaction vessel is doubled, how would it affect the rate of the reaction? [Ans. : Diminish to 1/8 of initial value]

26. Explain with an example, what is a pseudo first order reaction?
27. Show that time required for 99.9% completion of the first order reaction is 10 times of $t_{1/2}$ for first order chemical reaction.
28. The graphs (1 and 2) given below are plots of rate of reaction verses concentration of the reaction. Predict the order from the graphs.

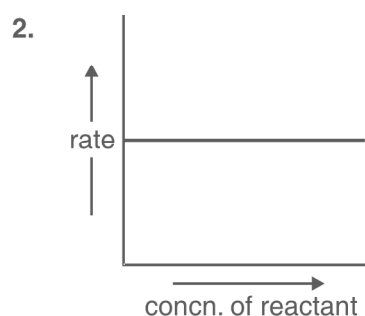
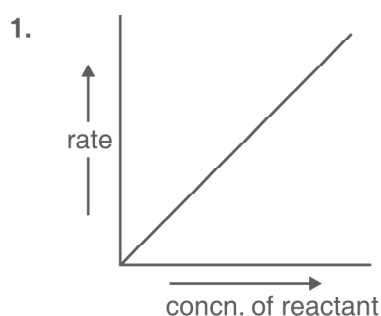

29. (a) For a reaction $A + B \rightarrow \text{Products}$, the rate law is given by

$$r = k [A]^{1/2} [B]^2$$

What is the order of reaction?

- (b) the conversion of molecules X to Y follows second order kinetics. If concentration of X is increased to three times, how will it affect the rate of formation of Y? [Ans. : (a) 5/2; (b) 9 times]

SA (II) TYPE QUESTIONS (3 - MARK QUESTIONS)

31. What is meant by zero order reaction? Derive an integrated rate equation for a zero order reaction.
32. (a) Write two points of difference between order of reaction and molecularity of a reaction.
- (b) Write one point of difference between rate of reaction and rate constant.
33. Draw a graph between fraction of molecules and kinetic energy of the reacting species for two different temperatures :
- (a) Room temperature
- (b) Temperature 10°C higher than the room temperature
- (c) Indicate the fraction of additional molecules which react at $(t + 10)^\circ\text{C}$.

LONG ANSWER TYPE QUESTIONS (5 - MARK - QUESTIONS)

34. (a) A chemical reaction is of second order w.r.t. a reactant. How will the rate of reaction be affected if the concentration of this reactant is :
(a) doubled; (b) reduced to 1/8th.

[Ans. : (a) Four times (b) 1/64]

- (b) For the reaction



the following data were collected. All the measurements were taken at 263k

Experiment No.	Initial [NO] / M	Initial [Cl ₂] / M	Initial rate of disappearance of Cl ₂ [M / min]
1	0.15	0.15	0.60
2	0.15	0.30	1.20
3	0.30	0.15	2.40
4	0.25	0.25	?

- (i) Write the expression for rate law.
(ii) Calculate the value of rate constant and specify its units.
(iii) What is the initial rate of disappearance of Cl₂ in exp. 4?

[Ans.: (i) Rate = k [NO]² [Cl₂], (ii) k = 177.7 L² mol⁻² min⁻¹, (iii) 2.7765 M/min

35. (a) Draw a plot between log k and reciprocal of absolute temperature (T).
(b) The energy of activation for a chemical reaction is 100 kJ/mol. Presence of a catalyst lowers the energy of activation by 75%. What will be effect on the rate of reaction at 20°C, if other factors are equal?
36. (a) Derive the equation for rate constant of a first order reaction. What would be the units of the first order rate constant if the concentration is expressed in moles per litre and time in seconds?
(b) For first order chemical reaction half life period (t_{1/2}) is concentration independent. Justify the statement by using integrated rate equation.

NUMERICALS

37. The reaction $\text{SO}_2\text{Cl}_2(\text{g}) \xrightarrow{k} \text{SO}_2(\text{g}) + \text{Cl}_2(\text{g})$ is a first order reaction with half life of 3.15×10^4 s at 575 K. What percentage of SO_2Cl_2 would be decomposed on heating at 575K for 90 min. [Ans. : 11.2%]
38. A certain reaction is 50% complete in 20 min at 300K and the same reaction is again 50% complete in 5 min at 350K. Calculate the activation energy if it is a first order reaction.
($R = 8.314 \text{ J K}^{-1} \text{ mol}^{-1}$, $\log 4 = 0.602$) [Ans. : 24.206 kJ/mol]
39. For a chemical reaction $\text{A} \rightarrow \text{B}$, it was found that concentration of B increases by 0.2 mol L^{-1} in half an hour. What is the average rate of reaction.
[Ans. : $0.0066 \text{ mol L}^{-1} \text{ min}^{-1}$]
40. In the reaction $\text{R} \rightarrow \text{P}$, the concentration of R decreases from 0.03M to 0.02 M in 25 minutes. Calculate the average rate of reaction using unit of time both in minutes and seconds.
[Ans. : $4 \times 10^{-4} \text{ M min}^{-1}$, $6.66 \times 10^{-6} \text{ M s}^{-1}$]
41. A first order reaction has a rate constant $1.15 \times 10^{-3} \text{ s}^{-1}$. How long will 5g of this reactant take to reduce to 3g? [Ans. : $t = 444 \text{ s}$]
42. The rate of reaction triples when the temperature changes from 20°C to 50°C . Calculate the energy of activation. [$R = 8.314 \text{ J K}^{-1} \text{ mol}^{-1}$, $\log 3 = 0.48$] [Ans. : 12.59 kJ]
43. A hydrogenation reaction is carried out at 550 K. If the same reaction is carried out in the presence of a catalyst at the same rate, the temperature required is 400 K. Calculate the activation energy of the reaction if the catalyst lowers the activation barrier by 20 kJ mol^{-1} .
[Hint : $k = Ae^{-E_a/RT}$. In the absence of catalyst, $E_a = x \text{ kJ mol}^{-1}$. In the presence of catalyst, $E_a = (x - 20) \text{ kJ mol}^{-1}$] [Ans. : $E_a = 100 \text{ kJ mol}^{-1}$]
44. The rate constant for the first order decomposition of H_2O_2 is given by the following equation $\log k = 14.34 - 1.25 \times 10^4 \text{ K/T}$. Calculate E_a for this reaction and at what temperature will its half-life be 256 minutes.
[Ans. : $E_a = 239.34 \text{ kJ}$; $T = 670\text{K}$]
45. Show that for a first order reaction, time required for 99% completion is twice for the time required for the 90% completion of reaction.

46. The experimental data for the reaction : $2A + B_2 \rightarrow 2AB$, are as follows. Write probable rate expression.

$[A] \text{ mol/L}^{-1}$	$[B_2] \text{ mol/L}^{-1}$	Initial rate ($\text{mol L}^{-1} \text{ sec}^{-1}$)
0.5	0.5	1.6×10^{-4}
0.5	1.0	3.2×10^{-4}
1.0	1.0	3.2×10^{-4}

[Ans : Rate = k $[B_2]$]

47. A reaction is 20% complete in 20 minutes. Calculate the time required for 80% completion of reaction, If reaction follows the first order kinetics.

[Ans. : 144 min]

48. The decomposition of phosphine $4PH_3(g) \rightarrow P_4(g) + 6H_2(g)$ has rate law; Rate = k $[PH_3]$. The rate constant is $6.0 \times 10^{-4} \text{ s}^{-1}$ at 300K and activation energy is $3.05 \times 10^5 \text{ J mol}^{-1}$. Calculate the value of the rate constant at 310K. ($R = 8.314 \text{ J K}^{-1} \text{ mol}^{-1}$).

[Ans. : $30.97 \times 10^{-3} \text{ s}^{-1}$]

49. For the decomposition of azoisopropane to hexane and nitrogen at 543K, the following data is obtained.

t (sec.)	0	360	720
Pressure (atm.)	35.0	54.0	63.0

Calculate the rate constant.

[Ans. : $k_{360} = 2.17 \times 10^{-3} \text{ s}^{-1}$; $k_{720} = 2.24 \times 10^{-3} \text{ s}^{-1}$]

50. The decomposition of hydrocarbon follows the equation

$$k = (4.5 \times 10^{11} \text{ s}^{-1}) e^{-28000 \text{ K/T}}$$

Calculate activation energy (E_a).

[Ans. : $232.79 \text{ kJmol}^{-1}$]

Unit - 5

SURFACE CHEMISTRY

VSA QUESTIONS (1 - MARK QUESTIONS)

1. Why does a gas mixed with another gas not form a colloidal system?
2. Why are adsorbate particles attracted and retained on the surface of adsorbent?
3. Explain the terms sorption and desorption.
4. "Chemisorption is highly specific." Illustrate with an example.
5. "Adsorbents in finely divided form are more effective." Why?
6. Name two compounds used as adsorbent for controlling humidity.
[Ans. : Silica gel, Alumina gel]
7. Mention one shape selective catalyst used to convert alcohol directly into gasoline.
8. 'Generally high temperature is favourable for chemisorption.' Why?
9. Name the catalyst used in the following process :
 - (a) Haber's process for the manufacture of NH_3 gas.
 - (b) Ostwald process for the manufacture of nitric acid.
10. Explain the relationship given by Freundlich in adsorption isotherm.
11. Which group elements show maximum catalytic activity for hydrogenation reactions?
[Hint : 7–9 group elements]
12. Why gas masks are used by miners in coal mines while working?
13. Write the chemical reaction involved in the preparation of sulphur sol.
14. Name the enzyme which converts milk into curd. [Ans. : lactobacilli]

15. What are the optimum temperature and pH at which enzymes are highly active. [Ans. : Temperature 298–310K and pH 5 to 7]
16. What are the physical states of dispersed phase and dispersion medium in foam rubber.
18. What is the composition of colloidal solution?
19. Why do colloidal particles show Brownian movement?
[Hint : Due to unbalanced bombardment of the particles by the molecules of the dispersion medium]
21. State the sign of entropy change involved when the molecules of a substance get adsorbed on a solid surface. [Ans. : $\Delta S = -ve$]
22. Why does sky appear blue to us?
23. What happens when hydrated ferric oxide and arsenious sulphide sols are mixed in almost equal proportions?
24. Gelatin is generally added to ice-cream. Why?
[Hint : Ice-cream is water in oil type emulsion and gelatin acts as emulsifier].
25. How is lake test for aluminium ion based upon adsorption?
[Hint : $Al_2O_3 \cdot xH_2O$ has the capacity to adsorb the colour of blue litmus from the solution]
26. What is saturation pressure in Freundlich's isotherm?
27. Mention the two conditions for the formation of micelles.
[Hint. : CMC and T_k]
28. How is Brownian movement responsible for the stability of sols?
[Hint : Stirring effect due to Brownian movement does not allow the particles to settle down.]
29. Which of the following is more effective in coagulating positively charged hydrated ferric oxide sol : (i) KCl (ii) $CaSO_4$ (iii) $K_3[Fe(CN)_6]$.
30. State the purpose of impregnating the filter paper with colloidal solution.
31. Mention one use of ZSM-5 catalyst.

SA (I) TYPE QUESTIONS (2 - MARK QUESTIONS)

35. Explain the effect of temperature on the extent of physical and chemical adsorption.
36. Define the term peptization and mention its cause.
37. What will be the charge on colloidal solutions in the following cases.

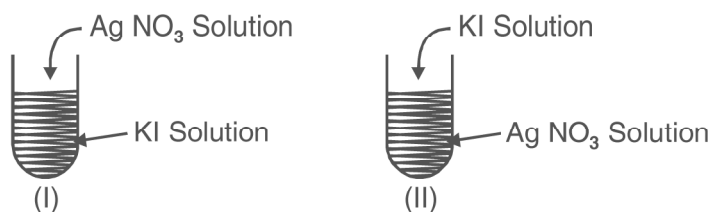

Give reasons for the origin of charge.

38. Write the factors upon which the catalytic reaction of shape-selective catalyst depends?

[Hint : (a) Pore structure of the catalyst; (b) Size and shape of the reactant and product molecules.]

39. Mention two examples of emulsifying agents for o/w emulsions and w/o emulsions.
40. Suggest a mechanism of enzyme catalysed reaction.
41. A small amount of silica gel and a small amount of anhydrous calcium chloride are placed separately in two beakers containing water vapour. Name of phenomenon that takes place in both the beakers.

[Hint : Silica gel – Adsorption, Anhydrous CaCl₂–Absorption, as it forms CaCl₂· 2H₂O)

42. Write the differences between adsorption and absorption?
43. How can physisorption be distinguished from chemisorption?
44. Classify the following reactions as homogeneous and heterogeneous catalysis :

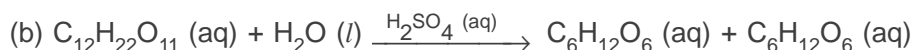
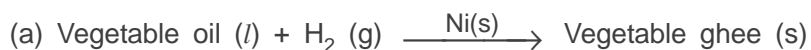

45. In what way these are different : (a) a sol and a gel (b) a gel and an emulsion.
46. State "Hardy Schulze Rule" with one example.
47. What is an emulsifying agent? What role does it play in forming an emulsion?
48. Define the terms :
- Helmholtz electrical double layer.
 - Zeta potential.
49. A graph between $\frac{x}{m}$ and $\log p$ is a straight line at an angle of 45° with intercept on the y-axis i.e. $(\log k)$ equal to 0.3010. Calculate the amount of the gas absorbed per gram of the adsorbent under a pressure of 0.5 atmosphere.

$$\left[\begin{array}{l} \text{Hint : Refer to NCERT Text Book page 125, Fig. 5.2} \\ \frac{1}{n} = \tan 45^\circ = 1, \log k = 0.3010, k = 2, p = 0.5 \text{ atm.} \\ \frac{x}{m} = kp^{\frac{1}{n}} = 2 \times (0.5)^1 = 1.0 \end{array} \right]$$

50. Mention the two necessary conditions for the observation of Tyndall Effect.
51. Account for the following :
- Artificial rain can be caused by spraying electrified sand on the clouds.
 - Electrical precipitation of smoke.
52. Write chemical equations for the preparation of sols :
- Gold sol by reduction.
 - hydrated ferric oxide sol by hydrolysis.
53. How can the two emulsions can be distinguished :
- oil in water type (O/W) and
 - water in oil type (W/O)

SA (II) TYPE QUESTIONS (3 - MARK QUESTIONS)

54. Write the difference between
- catalysts and enzymes
 - promoters and poisons
55. Write the steps of 'Modern Adsorption Theory of Heterogenous Catalysis.'
56. Mention the two important features of solid catalysts and explain with the help of suitable examples.
57. How are the following colloids different from each other in respect of dispersion medium and dispersed phase? Give one example of each type.
- An aerosol
 - A hydrosol
 - An emulsion.
58. What happens :
- by persistent dialysis of a sol.
 - when river water meets the sea water.
 - when alum is applied on cuts during bleeding.
59. Distinguish between multimolecular, macromolecular and associated colloids with the help of one example of each.
60. (a) Which property of colloids is responsible for the sun to look red at the time of setting?
- (b) C_2H_2 on addition with H_2 forms ethane in presence of palladium catalyst but if reaction is carried in the presence of barium sulphate and quinoline, the product is ethene and not ethane. Why?

[Ans. (a) Sun is at horizon and blue part of the light is scattered away by the dust particles as light has to travel a long distance through the atmosphere.

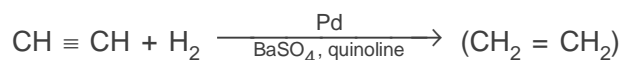
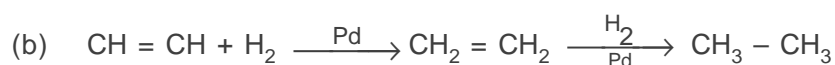

($BaSO_4$ in presence of quinoline act as poison. The catalyst in this case is not effective in further reduction].

Unit - 6

GENERAL PRINCIPLES AND PROCESSES OF ISOLATION OF ELEMENTS

VSA QUESTIONS (1 - MARK QUESTIONS)

1. Name three metals which occur in native state in nature.
[Ans. : Au, Ag and Pt]
2. What are collectors in froth floatation process? Give one example.
[Ex. : Pine oil]
- *3. Give the names and formulae of three ores which are concentrated by froth floatation process.
[Ans. : Galena (PbS), zinc blend (zns) cinnabar (HgS)]
4. Among Fe, Cu, Al and Pb, which metal (s) can not be obtained by smelting.
[Ans. : Al]
5. What is the thermodynamic criteria for the feasibility of a reaction?
[Ans. : ΔG should be $-ve$ or $\log K = + ve$]
8. Why can't aluminium be reduced by carbon?
[Hint : Al is stronger reducing agent than carbon]
9. Name the most important form of iron. Mention its one use.
[Ans. : Cast iron is used for making gutter pipes, castings, railway sleepers, toys etc.]
10. Name the impurities present in bauxite ore.
[Ans. : SiO_2 , Fe_2O_3 and TiO_2]
11. What is the composition of copper matte?
[Hint : Cu_2S and FeS]

12. Which form of copper is called blister copper?
13. What are froth stabilizers? Give two examples.
[Ex. : Cresol and aniline].
14. A sample of galena is contaminated with zinc blend. Name one chemical which can be used to concentrate galena selectively by froth floatation method.
[Ans. : NaCN]
15. What are the constituents of German silver?
[Ans. : Cu = 25-30%, Zn = 25-30%, Ni = 40-50%]
16. Why is froth floatation process selected for concentration of the sulphide ore?
[Ans. : Sulphide ore particles are wetted by oil (Pine oil) and gangue particles by water]
17. Write the reaction involved in the extraction of copper from low grade ores.
[Ans. : First step is leaching of ore with acid or bacteria then
 $\text{Cu}^{2+}(\text{aq}) + \text{H}_2(\text{g}) \rightarrow \text{Cu}(\text{s}) + 2\text{H}^+(\text{g})$]
18. Although aluminium is above hydrogen in the electrochemical series, it is stable in air and water. Why?
19. Which method of purification is represented by the following reaction
$$\text{Ti}(\text{s}) + 2\text{I}_2(\text{g}) \xrightarrow{523\text{K}} \text{TiI}_4(\text{g}) \xrightarrow{1700\text{K}} \text{Ti}(\text{s}) + 2\text{I}_2(\text{g})$$
20. Zinc is used but not copper for the recovery of metallic silver from the complex $[\text{Ag}(\text{CN})_2]^-$, although electrode potentials of both zinc and copper are less than that of Ag. Explain why?
[Hint : Zinc reacts at faster rate as compared with copper, further zinc is cheaper than copper].
21. Write the composition of molten mixture which is electrolysed to extract aluminium.

SA (I) QUESTIONS (2 - MARK QUESTIONS)

*22. What is hydrometallurgy? Give one example where it is used for metal extraction.

[Ans. : Leaching followed by reduction is called hydrometallurgy. It is used in extraction and copper

*23. Name the process for the benefaction/concentration of (i) an ore having lighter impurities (ii) sulphide ore.

24. Mention the role of cryolite in the extraction of aluminium.

25. Mention the role of following :

(a) SiO_2 in the metallurgy of Cu.

(b) CaCO_3 in the metallurgy of Fe.

(c) CO in the metallurgy of iron

(d) I_2 in the purification of zirconium.

26. Extraction of copper directly from sulphide ore is less favourable than from its oxide through reduction. Explain.

[Ans. : $2\text{CuS}(s) + \text{C}(s) \rightarrow \text{CS}_2(l) + 2\text{Cu}(s)$

$\text{CuO}(s) + \text{C}(s) \rightarrow \text{CO}(g) + \text{Cu}(s)$

ΔG value is more -ve in second case as compared with first case]

27. The graphite electrodes in the extraction of 'aluminium' by Hall-Heroult process need to be changed frequently. Why?

28. Write the chemical formulae of the following ores (a) Haematite (b) Magnetite (c) Limonite (d) Siderite.

[Ans. : (a) Fe_2O_3 (b) Fe_3O_4 (c) $\text{Fe}_2\text{O}_3 \cdot 2\text{H}_2\text{O}$ (d) FeCO_3]

29. Give equations for the industrial extraction of zinc from calamine.

[Ans. : $\text{ZnCO}_3 \rightarrow \text{ZnO} + \text{CO}_2$ (Calcination) $\text{ZnO} + \text{C} \rightarrow \text{Zn} + \text{CO}$ (Reduction)]

30. Name the elements present in anode mud during refining of copper. Why does it contain such elements?

[Ans. : Au and Ag. They are not oxidised at anode. They are less electropositive than copper.]

31. Write the Chemical reactions taking place in different zones in the blast furnace for the extraction of iron from its ore.

32. How are impurities separated from bauxite ore to get pure alumina?
33. Why is the reduction of a metal oxide easier if metal formed is in liquid state at the temperature of reduction?

[Hint : Entropy is more positive when the metal is in liquid state as compared with solid state, so ΔG becomes more $-ve$]

34. What is pyrometallurgy? Explain with one example.

[Ans. : A process of reducing a metal oxide by heating with either coke or some other reducing agent e.g., Al, Mg etc.

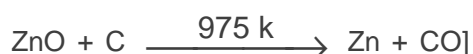

35. Write the method to produce Copper matte from copper pyrites.

- *38. Copper can be extracted by hydrometallurgy but not zinc. Explain why?

[Hint : $E^{\ominus}_{\text{Zn}^{2+}/\text{Zn}}$ is $-ve$, $E^{\ominus}_{\text{Cu}^{2+}/\text{Cu}}$ is $+ve$]

- *39. Gibbs energies of formation $\Delta_f G$ of MgO(s) and CO(g) at 1273K and 2273 K are given below:

$$\Delta_f G [\text{MgO(s)}] = -941 \text{ kJ mol}^{-1} \text{ at } 1273 \text{ K.}$$

$$\Delta_f G [\text{CO(g)}] = -439 \text{ kJ mol}^{-1} \text{ at } 1273 \text{ K.}$$

$$\Delta_f G [\text{MgO(s)}] = -314 \text{ kJ mol}^{-1} \text{ at } 2273 \text{ K.}$$

$$\Delta_f G [\text{CO(g)}] = -628 \text{ kJ mol}^{-1} \text{ at } 2273 \text{ K.}$$

On the basis of above data, predict the temperature at which carbon can be used as a reducing agent for MgO(s).

[Ans. : For the reaction, $\text{MgO(s)} + \text{C(s)} \rightarrow \text{Mg(s)} + \text{CO(g)}$

$$\text{At } 1273\text{K, } \Delta_r G = \Delta_f G[\text{CO(g)}] - \Delta_f G[\text{MgO(s)}] = -439 - (-941) \text{ kJ mol}^{-1} = 502 \text{ kJ mol}^{-1}$$

$$\text{At } 2273 \text{ K, } \Delta_r G = -628 - (-314) \text{ kJ mol}^{-1} = -314 \text{ kJ mol}^{-1}$$

The temperature is 2273 K]

SA (II) TYPE QUESTIONS (3 - MARK QUESTIONS)

- *40. State the principles of refining of metal by the following methods.
(a) Zone refining (b) Electrolytic refining (c) Vapour phase refining.
41. How is pure copper obtained from its principle ore? Write the chemical reactions occurring during the extraction.
42. Name the method of refining of the following metals –
(a) Hg (b) Sn (c) Cu (d) Ge (e) Ni (f) Zr
[Ans. : (a) Distillation, (b) Liquation; (c) Electrolytic refining
(d) Zone refining; (e) Mond Process (f) Van Arkel Process]
- *44. The native silver forms a water soluble compound (B) with dilute aqueous solution of NaCN in the presence of a gas (A). The silver metal is obtained by the addition of a metal (C) to (B) and complex (D) is formed as a byproduct. Write the structures of (C) and (D) and identify (A) and (B) in the following sequence –
$$\text{Ag} + \text{NaCN} + [\text{A}] + \text{H}_2\text{O} \rightarrow [\text{B}] + \text{OH}^- + \text{Na}^+.$$
$$[\text{C}] + [\text{B}] \rightarrow [\text{D}] + \text{Ag}.$$

[Ans. : [A] = O_2
[B] = $\text{Na} [\text{Ag}(\text{CN})_2]$
[C] = Zn
[D] = $\text{Na}_2 [\text{Zn} (\text{CN})_4]$].
45. In the cyanamide extraction process of silver from argentite ore, name the oxidising and reducing agents. Write the chemical equations of the reactions involved.

Unit - 7

Anomalous behaviour of first member of p-Block Elements

Anomalous behaviour of first element in the p-block elements is attributed to small size, large (charge/radius) ratio, high ionization enthalpy, high electronegativity and unavailability of d-orbitals in its valence shell.

Consequences :

1. The first element in p-block element has four valence orbitals i.e. one 2s and three 2p, Hence maximum covalency of the first element is limited to four. The other elements of the p-block elements have vacant d-orbitals in their valence shell, e.g. elements of the third period have nine (9) one 3s, three 3p and five three 3d orbitals. Hence these show maximum covalence greater than four. Following questions can be answered -
 - (i) Nitrogen (N) does not form pentahalide while P forms PCl_5 , PF_5 , and PF_6^- . Why?
 - (ii) Sulphur (S) forms SF_6 but oxygen does not form OF_6 . Why?
 - (iii) Though nitrogen forms pentoxide but it does not form pentachloride. Explain. Why?
 - (iv) Fluorine forms only one oxoacid while other halogens form a number of oxoacids. Why?
- (2) The first member of p-block elements displays greater ability to form $p\pi$ - $p\pi$ bond (s) with itself, (e.g., $\text{C} = \text{C}$, $\text{C} \equiv \text{C}$, $\text{N} = \text{N}$, $\text{N} \equiv \text{N}$) and with the other elements of second period (e.g., $\text{C} = \text{O}$, $\text{C} \equiv \text{N}$, $\text{N} = \text{O}$) compared to the subsequent members of the group.

This is because p-orbitals of the heavier members are so large and diffuse that they cannot have effective sideways overlapping. Heavier members can form $p_\pi - d_\pi$ bonds with oxygen.

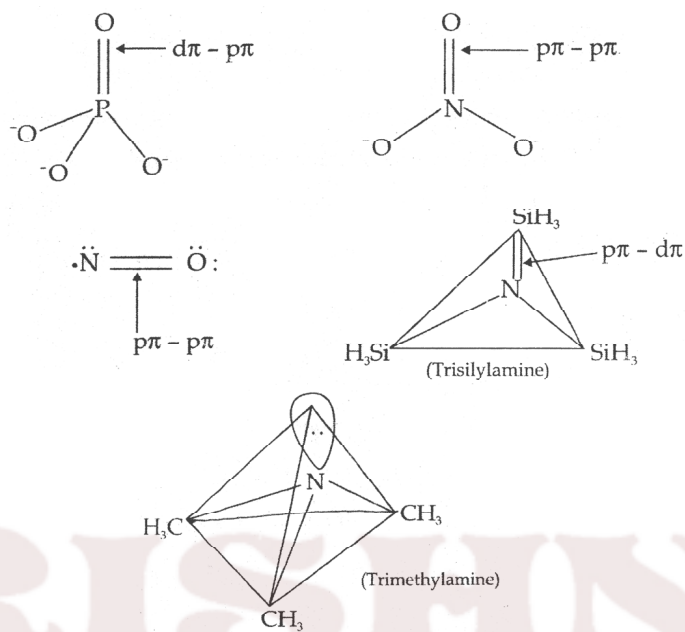

Nitrogen rarely forms $p\pi-d\pi$ bonds with heavier elements as in case of trisilylamine $(\text{SiH}_3)_3\text{N}$.



Now, the following questions can be explained using the above reasoning-

- (i) Nitrogen forms N_2 but phosphorus forms P_4 at room temperature. Why?
 - (ii) Oxygen forms O_2 but sulphur exists as S_8 . Why?
 - (iii) Explain why $(\text{CH}_3)_3\text{P} = \text{O}$ is known but $(\text{CH}_3)_3\text{N} = \text{O}$ is not known.
3. Due to small size and high electronegativity and presence of lone pair(s) of electrons, elements N, O, F when bonded to hydrogen atom, forms intermolecular hydrogen bonds which are stronger than other intermolecular forces. This results in exceptionally high m.p. and b.p. of the compounds having N-H/O-H/F-H bonds.

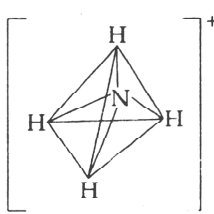
Shapes of some molecular/ionic species and hybridisation state of central atom.

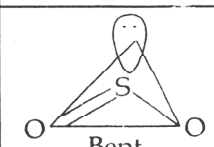
Lewis structure	lone pairs + bond pairs and hybridisation of central atom	Electron-pair geometry	Shape of species
$\left[\begin{array}{c} \text{H} \\ \\ \text{H}-\text{N}-\text{H} \\ \\ \text{H} \end{array} \right]^+$	$0 + 4 = 4$ (sp^3)	Tetrahedral	 Tetrahedral
$\begin{array}{c} \text{H}-\ddot{\text{N}}-\text{H} \\ \\ \text{H} \end{array}$	$1 + 3 = 4$ (sp^3)	Tetrahedral	 Pyramidal
$\begin{array}{c} \text{O}=\ddot{\text{Xe}}=\text{O} \\ \\ \text{O} \end{array}$	$1 + 3 = 4$ (sp^3)	Tetrahedral	Pyramidal
$\text{O}=\ddot{\text{S}}\rightarrow\text{O}$	$1 + 2 = 3$ (sp^2)	Trigonal planner	 Bent

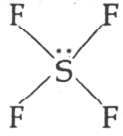
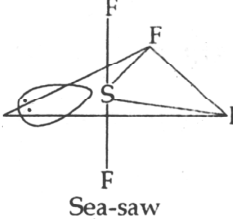
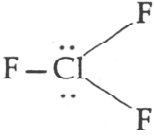
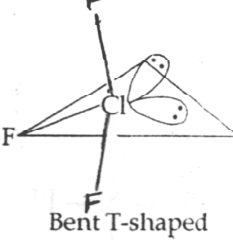
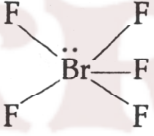
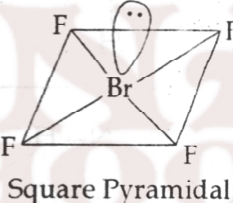
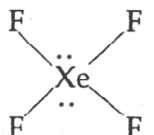
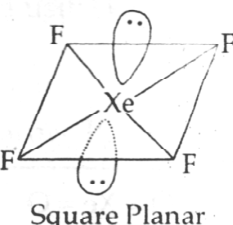
$O = C = O$	$0 + 2 = 2$ sp^2	Linear	Linear
	$1 + 4 = 5$ (sp^3d)	Trigonal-bipyramidal	 Sea-saw
	$2 + 3 = 5$ (sp^3d)	Trigonal-bipyramidal	 Bent T-shaped
	$1 + 5 = 6$ (sp^3d^2)	Octahedral	 Square Pyramidal
	$2 + 4 = 6$ (sp^3d^2)	Octahedral	 Square Planar

Note: Multiple bond is treated as single super pair. A π -bond shortens the bond length without affecting the geometry.

The state of hybridisation of the central atom is determined by sum of bond pairs and lone pair (s) if present around the central atom in a molecule/ion.

Isostructural species have same number of bond pairs and lone pairs if present around the central atom in a molecule/ion. Thus, they have the same geometry/shape/structure and the same hybridisation scheme. For example ICl_4^- / XeF_4 , BrO_3^- / XeO_3 , BH_4^- / NH_4^+ are the pairs of isostructural species.

Inert pair effect : Due to poor shielding effect of intervening d and/ or f-electrons, the effective nuclear charge is increased. This increased nuclear charge holds the ns^2 electrons of heavier elements to participate in bonding and the tendency of ns^2 electrons to take part in bonding is more and more restricted down the group. Consequently, more stable lower oxidation state which is two units less than higher oxidation state becomes more and more stable than the higher oxidation state. For example, following questions can be explained with the help of inert pair effect.

- For N and P, + 5 oxidation state is more stable than + 3 oxidation state but for Bi, + 3 oxidation state is more stable than + 5. Explain why?
- NaBiO_3 is a strong oxidising agent. Why?
(Hint : Bi(v) is least stable O.S.).
- In group 16 stability of + 6 oxidation state decreases and the stability of + 4 oxidation increases down the group. Why?
- SO_2 acts as reducing agent. Explain why?
- Why is BrO_4^- a stronger oxidising agent than ClO_4^- ?
[Hint : It is because + 7 oxidation state is less stable in BrO_4^- due to which Br – O bond becomes weaker.]
- BiCl_5 is highly unstable.
- The stability of highest oxidation state of 4p element is less than those of 3p and 5p elements of the same group?

Bond Length : Resonance averages bond lengths. The two oxygen–oxygen bond lengths are identical in the O_3 molecule because it is resonance hybrid of two canonical forms.

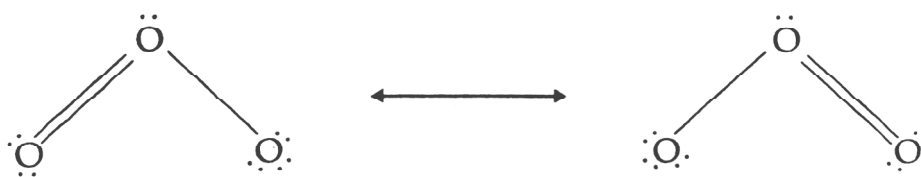

In case of HNO_3 , two nitrogen–oxygen bonds are identical and smaller than the third nitrogen–oxygen bond.

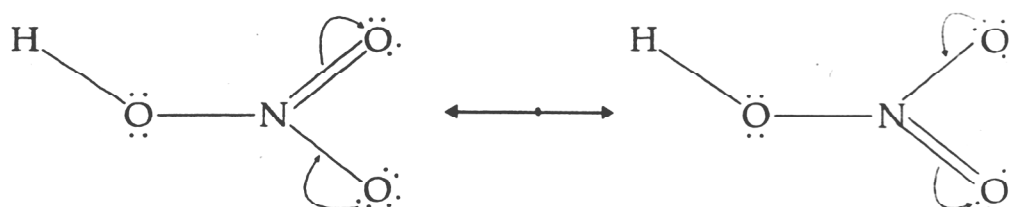

Now the following questions can be explained on the basis of this concept.

- (i) In SO_2 , the two sulphur-oxygen bonds are identical. Explain why?
- (ii) In NO_3^- ion all the three N–O bonds are identical. Why?

Bond angle : In regular structures (where no lone pairs are present in the valence shell of the central atom in a molecule/ion), the bond angle does not depend upon the size/electronegativity of the central or terminal atoms.

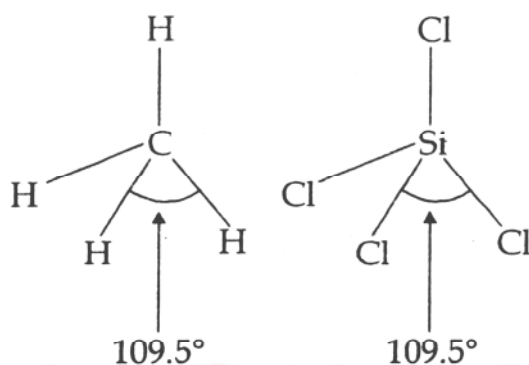

In presence of lone pair(s) on the central atom, the geometry is distorted and the bond angle is changed.

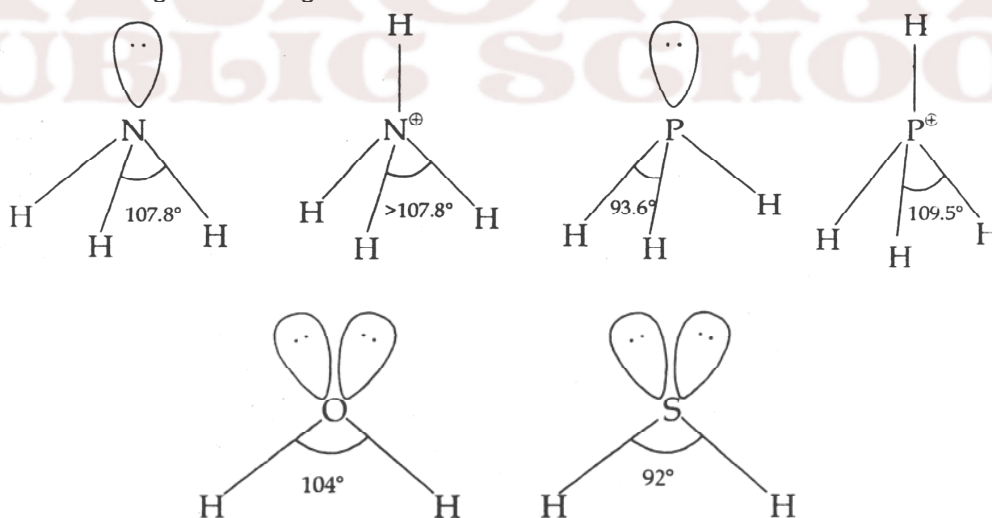

Comparison of HNH and HPH bond angles

Since N is more electronegative than P, the bonding electron pair of N–H bond will shift more towards N atom than the bonding electron pair of P–H bond would shift towards P atom. This results in more bond pair-bond pair repulsion in NH_3

molecules than PH_3 molecule. Because of lp-bp repulsion the N–H are pushed closer to a less extent than in PH_3 , Consequently, HNH bond angle is greater than HPH angle.

Now the following questions can be explained using the above mentioned concept.

- (i) Bond angle in PH_4^+ ion is higher than in PH_3 . Why?
- (ii) H–O–H bond in H_2O is greater than H–S–H angle in H_2S . Why?
- (iii) Cl–P–Cl bond angle in PCl_3 (100°) is less than F–N–F bond angle in NF_3 (102°). Explain why?
- (iv) Bond angle in OF_2 (105°) molecule is less than in OCl_2 (110°). Why?

Boiling and melting points of hydrides depends upon the molar mass (or surface area) of molecules. More the molar mass, the higher in the m.p. and b.p. Hydrides forming intermolecular hydrogen bonds have exceptionally high m.p. and b.p. since intermolecular hydrogen bonds are stronger than the Van der waals forces.

Increasing order of melting point and boiling point of hydrides is as given below :

$\text{PH}_3 < \text{AsH}_3 < \text{SbH}_3 < \text{NH}_3$; Melting point

$\text{PH}_3 < \text{AsH}_3 < \text{NH}_3 < \text{SbH}_3$; Boiling point

$\text{H}_2\text{S} < \text{H}_2\text{Se} < \text{H}_2\text{Te} < \text{H}_2\text{O}$; Melting point and Boiling point

$\text{HCl} < \text{HBr} < \text{HI} < \text{HF}$; Boiling point

$\text{HCl} < \text{HBr} < \text{HF} < \text{HI}$; Melting point

Thermal stability, reducing power and acid strength of hydrides depend upon bond dissociation enthalpy of E - H bond (E = group 15, group 16, and group 17 element). Due to the increase in size down the group, bond dissociation enthalpy of E - H bond decreases. Consequently, thermal stability, reducing power and acid strength of hydrides increases down the group.

The following questions can be explained using the above concepts.

Explain why :

- (i) NH_3 has higher boiling point than PH_3 .
- (ii) H_2O is liquid and H_2S is gas or H_2S is more volatile than H_2O .
- (iii) HE is weaker acid than HCl.
- (iv) Among hydrogen halides, HI is the strongest reducing agent.
- (v) H_2Te is more acidic than H_2S .

- (vi) NH_3 is mild oxidising agent while BiH_3 is the strongest reducing agent among the group-15 hydrides.
- (vii) H_2S is weaker reducing agent than H_2Te .

Basic nature of hydrides EH_3 of group 15 elements

All the hydrides EH_3 has one lone pair of electron. In ammonia the lone pair of electron is present in, sp^3 hybrid orbital of the N-atom. The sp^3 hybrid orbital is directional and further N is more electronegative than H, the bond pair of N - H is shifted towards N atom which further increases the electron density on N atom. In PH_3 , the lone pair of electron is present in large and more diffuse 3s orbital which is non-directional. As a result PH_3 is less basic than NH_3 and basic character decreases down the group. NH_3 donates electron pair more readily than PH_3 . $(\text{SiH}_3)_3\text{N}$ has less Lewis basic nature than that of $(\text{CH}_3)_3\text{N}$ because lone pair of electrons in p - orbital of N atom in $(\text{SiH}_3)_3\text{N}$ is transferred to the vacant d - orbital of Si atom forming $d\pi - p\pi$ bond.

COVALENT/IONIC CHARACTER OF HALIDES

Pentahalides are more covalent than trihalides since the element (E) in higher oxidation state (+ 5) has more polarising power than element (E) in lower oxidation state (+ 3) in trihalides, Similarly SnCl_4 , PbCl_4 , SbCl_5 and UF_6 are more covalent than SnCl_2 , PbCl_2 , SbCl_3 and UF_4 respectively.

Following questions can be explained by using this concept. Explain why :

- (i) SnCl_2 has more b.p. than SnCl_4 .
- (ii) SbCl_5 is more covalent than SbCl_3 .
- (iii) PCl_5 has lower boiling point than that of PCl_3 .

Oxoacids of N, P and halogens :

Strength of oxoacid depends upon the polarity of O-H bond which in turn, depends on the electron withdrawing power (or electronegativity) of the element E. Strength of oxoacids increase if the number of oxygen atom bonded with E increases.

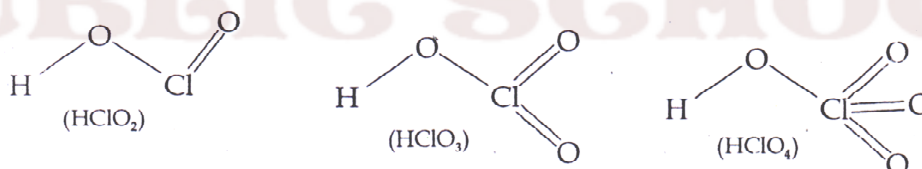
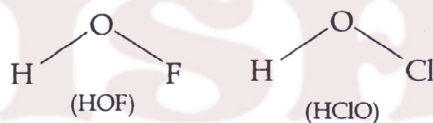
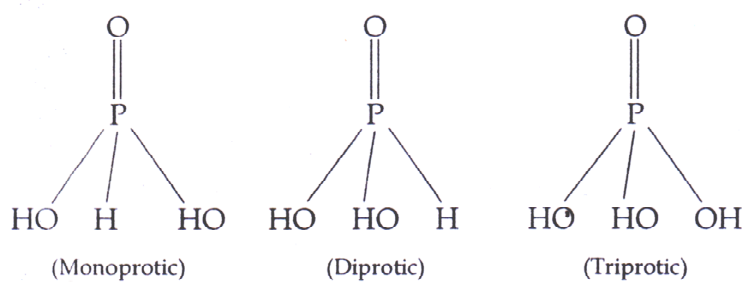
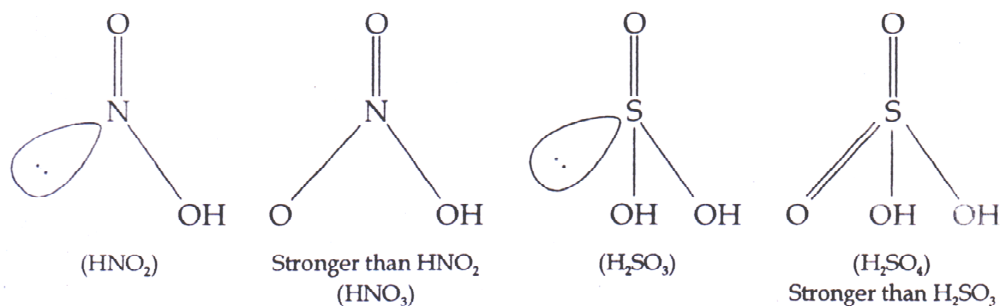

Strength of oxoacid of halogens in the same oxidation state depends on the electronegativity of the halogen. The more the electronegativity, stronger is the oxoacid.

Strength of oxoacid of a halogen in different oxidation state increases with the increase in oxidation state. This is because the stabilisation of the oxoanion increases with the number of the oxygen atoms bonded to the halogen atom. More the number of oxygen atoms, the more the dispersal of $-ve$ charge present on the oxoanion and stronger will be the oxoacid.

Oxidising power of halogens :

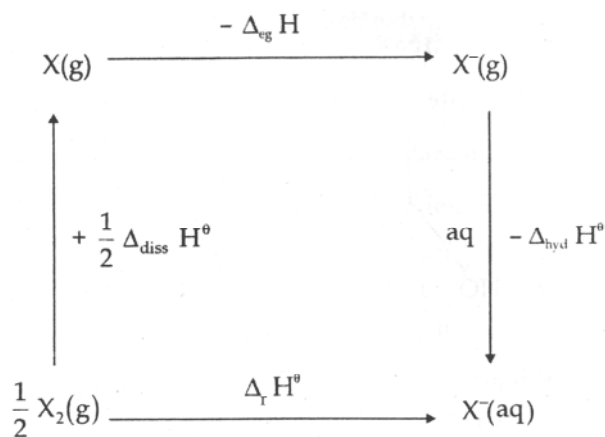

The more negative the value of $\Delta_r H^\theta = \frac{1}{2} \Delta_{diss} H^\theta - \Delta_{eg} H^\theta - \Delta_{hyd} H^\theta$, the higher will be oxidising property of the halogen and more positive will be standard reduction potential E^θ_{red} of the halogen.

Following questions can be explained on the basis of parameters e.g., $\Delta_{diss} H^\theta$, $\Delta_{eg} H^\theta$ and $\Delta_{hyd} H^\theta$.

- (i) Why does F_2 have exceptionally low bond dissociation enthalpy?
- (ii) Although electron gain enthalpy of fluorine(F) is less negative as compared to chlorine. (Cl), Fluorine (F_2) is a stronger oxidising agent than Cl_2 . Why?

VSA QUESTIONS (1 - MARK QUESTIONS)

1. In group 15 elements, there is considerable increase in covalent radius from N to P but small increase from As to Bi. Why?

[Hint : Due to completely filled d- and / or f-orbitals in As, Sb and Bi.

2. The tendency to exhibit – 3 oxidation state, decreases down the group in group 15 elements. Explain.

[Hint : Due to increase in size and decrease in electronegativity down the groups].

3. Maximum covalence of Nitrogen is '4' but the heavier elements of group 15 show covalence greater than '4'. Why?

4. Nitrogen exists as a diatomic molecule with a triple bond between the two atoms, whereas the heavier elements of the group do not exist as E_2 at room temperature. Assign a reason.

[Hint : $p_\pi - p_\pi$ multiple bonds are formed by N due to its small size.]

5. The ionization enthalpies of group 15 elements are higher than those of corresponding members of group 14 and 16 elements. Assign the reason.

6. The boiling point of PH_3 is lesser than NH_3 . Why?

7. NO_2 dimerises to form N_2O_4 . Why?

[Hint : Due to presence of odd electron on N]

8. Draw the structure of N_2O_5 molecule.

9. How does ammonia solution react with Ag^+ (aq)? Write the balanced chemical equation.

10. Why does NH_3 forms intermolecular hydrogen bonds whereas PH_3 does not?

[Hint : Due to strong electronegativity, small size of Nitrogen atom and presence of lone pair of electrons on N atom]

11. Write disproportionation reaction of H_3PO_3 ?

12. How does NH_3 acts as a complexing agent?

[Hint : Metal hydroxides are dissolved in excess of NH_4OH . Ammonia acts as a Lewis base].

13. Why HF is the weakest acid and HI is the strongest.

Hint : K_a : (HF) = 7×10^{-4} (HI) = 7×10^{11}

Intermolecular H-bonds in H-F and high bond dissociation enthalpy of H-F makes it weakest and weak bond in H-I makes it strongest.

14. Explain why halogens are strong oxidising agents.
[Hint : Ready acceptance of electron due to more negative electron gain enthalpy.]

15. Why is Bi(V) a stronger oxidant than Sb(V)?
[Hint : +3 oxidation state is more stable than +5 oxidation state in Bi].

16. Why SF_4 is easily hydrolysed, whereas SF_6 is resistant to hydrolysis?
[Hint : Water molecule can not attack 'S' atom due to steric hindrance and 'S' atom is also coordinately saturated in SF_6 molecule.]

17. Bond dissociation enthalpy of F_2 is less than that of Cl_2 . Why?

18. Write the reaction of PCl_5 with heavy water.

[Hint : $PCl_5 + D_2O \rightarrow POCl_3 + 2DCl$]

19. How many P – O – P bonds are there in cyclotrimetaphosphoric acid?

[Hint : 3 bonds]

20. In group 16, the stability of +6 oxidation state decreases and that of +4 oxidation state increases down the group. Why?

[Hint : due to inert pair effect]

21. Why we can not prepare HBr by heating KBr with sulphuric acid.

[Hint : As HBr readily reduces H_2SO_4 forming Br_2]

24. Fluorine exhibit only –1 oxidation state whereas other halogens exhibit +ve oxidation states also. Explain.

25. Arrange the following oxoacids of chlorine in increasing order of acidic strength.

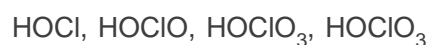

*26. The majority of known noble gas compounds are those of Xenon. Why?

*27. "Hypophosphorous acid is a good reducing agent." Justify with an example.

[Hint : $4AgNO_3 + H_3PO_2 + 2H_2O \rightarrow 4Ag + HNO_3 + H_3PO_4$]

*28. Draw the structure of $H_4P_2O_7$ and find out its basicity?

[Hint : Tetrabasic]

- *29. Arrange the following triatomic species in the order of increasing bond angle.

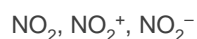

NO_2 has one non-bonding electron, NO_2^- has two non-bonding electrons, NO_2^+ has no non-bonding electron on N atom. Bond angle of NO_2^+ is maximum that of NO_2^- minimum].

30. With what neutral molecule ClO^- is isoelectronic?
 31. Draw the structure of $\text{H}_2\text{S}_2\text{O}_8$ and find the number of S–S bond if any.
 32. What is cause of bleaching action of chlorine water? Explain it with chemical equation?

[Hint : Formation of nascent oxygen]

- *33. Electron gain enthalpy of fluorine is more negative than that of chlorine.

[Hint. : Due to small size of F atom, there are strong interelectronic repulsions in the relatively smaller 2p orbitals of fluorine. So the incoming electron does experience less attraction than in Cl]

- *34. Which one of the following is not oxidised by O_3 . State the reason.
 KI, FeSO_4 , K_2MnO_4 , KMnO_4

[Hint. : KMnO_4 since Mn is showing maximum oxidation state of +7.]

SA (I) TYPE QUESTIONS (2 - MARK QUESTIONS)

2. Why is red phosphorus denser and less chemically reactive than white phosphorus?
 3. Give chemical reaction in support of the statement that all the bonds in PCl_5 molecule are not equivalent.

[Hint : $\text{PCl}_5 + \text{H}_2\text{O} \rightarrow \text{POCl}_3 + 2\text{HCl}$]

4. Account for the following :
 (a) XeF_2 has linear structure and not a bent structure.
 (b) Phosphorus show marked tendency for Catenation.
 5. Draw the structures of BrF_3 , XeOF_4 , XeO_3 using VSEPR theory.
 6. Write the conditions that favour the formation of ammonia gas along with the reactions involved in Haber's Process.

7. Write the chemical equations of the following reactions

(a) Glucose is heated with conc. H_2SO_4 .

(b) Sodium nitrate is heated with conc. H_2SO_4 .

Complete the following reactions :

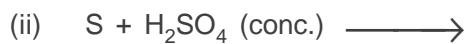
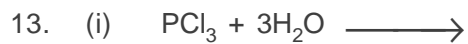
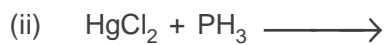
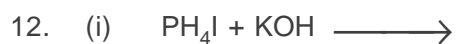
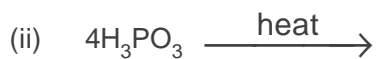
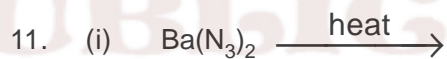
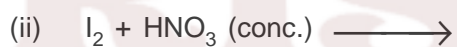
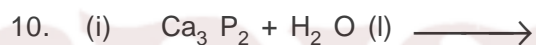
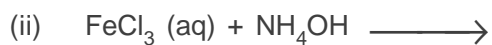
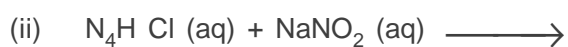
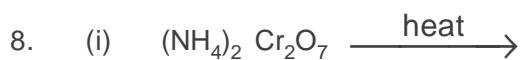

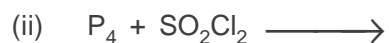
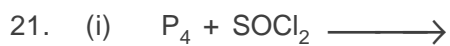
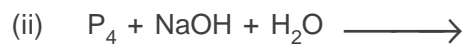
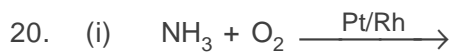
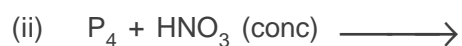
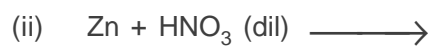
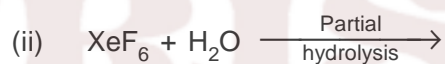
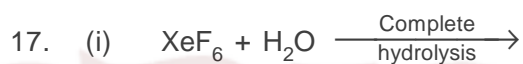
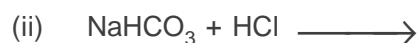
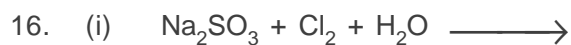
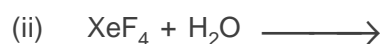
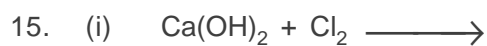
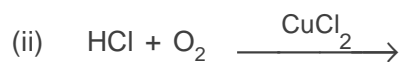

22. (i) $\text{PbS} + \text{O}_3 \longrightarrow$
(ii) $\text{KI} + \text{H}_2\text{O} + \text{O}_3 \longrightarrow$
23. (i) $\text{MnO}_4^- + \text{SO}_2 + \text{H}_2\text{O} \longrightarrow$
(ii) $\text{Zn} + \text{HNO}_3 \longrightarrow$
(dil)
24. (i) NH_3 (Excess) + $\text{Cl}_2 \longrightarrow$
(ii) $\text{NH}_3 + \text{Cl}_2$ (Excess) \longrightarrow
25. (i) $\text{Cl}_2 + \text{NaOH}$ (cold and dil) \longrightarrow
(ii) $\text{Cl}_2 + \text{NaOH}$ (hot & conc) \longrightarrow
26. (i) $\text{Fe} + \text{HCl} \longrightarrow$
(ii) $\text{Cl}_2 + \text{F}_2$ (Excess) \longrightarrow
27. (i) $\text{U} + \text{ClF}_3 \longrightarrow$
(ii) $\text{FeSO}_4 + \text{H}_2\text{SO}_4 + \text{Cl}_2 \longrightarrow$
28. (i) What is the covalency of N in N_2O_5 ?
(ii) Explain why phosphorus forms pentachloride whereas nitrogen and bismuth do not?
29. (i) The acidic character of hydrides of group 15 increases from H_2O to H_2Te . Why?
(ii) Dioxygen is a gas while sulphur (S_8) is a solid. Why?

30. (i) Interhalogen compounds are more reactive than halogens except F_2 . Why?
 (ii) Give one important use of ClF_3 .
31. (i) Write the composition of bleaching powder.
 (ii) What happens when $NaCl$ is heated with conc. H_2SO_4 in the presence of MnO_2 . Write the chemical equation.
32. Arrange the following in the decreasing order of their basicity. Assign the reason :
 $PH_3, NH_3, SbH_3, AsH_3, BiH_3$.
- *33. A colourless and a pungent smelling gas which easily liquifies to a colourless liquid and freezes to a white crystalline solid, gives dense white fumes with ammonia. Identify the gas and write the chemical equation for its laboratory preparation. **[Hint : HCl]**
- *34. Complete following disproportionation reactions.
- (a) $P_4 + NaOH + H_2O \longrightarrow$
- (b) $HNO_2 \xrightarrow{H^+}$
35. Arrange the following trichlorides in decreasing order of bond angle $NCl_3, PCl_3, AsCl_3, SbCl_3$
36. Suggest reason why only known binary compounds of noble gases are fluorides and oxides of Krypton, Xenon.
[Hint : F and O are most electronegative elements. Kr and Xe both have low ionisation enthalpies.]
37. Which fluorinating agent are oftenly used instead of F_2 ? Write two chemical equations showing their use as fluorinating agents.
**[Hint : $BrF_5 + 3H_2O \rightarrow HBrO_3 + 5HF$
 $2IF_7 + SiO_2 \rightarrow 2IOF_5 + SiF_4$]**
38. (a) Hydrolysis of XeF_6 is not regarded as a redox reaction. Why?
 (b) Write a chemical equation to represent the oxidising nature of XeF_4 .
[Hint : (b) $XeF_4 + 2H_2 \rightarrow Xe + 4HF$]
39. Write Chemical equation :
 (a) XeF_2 is hydrolysed
 (b) PtF_6 and Xenon are mixed together.

SA (II) TYPE QUESTIONS (3 - MARK QUESTIONS)

- How is HNO_3 prepared commercially?
 - Write chemical equations of the reactions involved.
 - What concentration by mass of HNO_3 is obtained?
 - How does O_3 react with lead sulphide? Write chemical equation.
 - What happens when SO_2 is passed in acidified KMnO_4 solution?
 - SO_2 behaves with lime water similar to CO_2 .
 - Assign reason for the following :
 - Sulphur in vapour state exhibits paramagnetism.
 - F_2 is strongest oxidising agent among halogens.
 - In spite of having same electronegativity, oxygen forms hydrogen bond while chlorine does not.
 - Give appropriate reason for each of the following :
 - Metal fluorides are more ionic than metal chlorides.
 - Perchloric acid is stronger than sulphuric acid.
 - Addition of chlorine to KI solution gives it a brown colour but excess of Cl_2 makes it colourless.
- [Hint :**
- According to Fajan's Rule, bigger ions more are polarised than the smaller ion by a particular cation.
 - ClO_4^- is more resonance stabilised than SO_4^{2-} since dispersal of negative charge is more effective in ClO_4^- as compared with SO_4^{2-}
 - $2\text{KI} + \text{Cl}_2 \rightarrow 2\text{KCl} + \text{I}_2$
Excess $5\text{Cl}_2 + \text{I}_2 + 6\text{H}_2\text{O} \rightarrow 2\text{HIO}_3 + 10 \text{HCl}$ (Colourless).
- Explain why :
 - No chemical compound of helium is known.
 - Bond dissociation energy of fluorine is less than that of chlorine.
 - Two S–O bonds in SO_2 are identical.
 - Out of the following hydrides of group 16 elements, which will have :
 - H_2S
 - H_2O
 - H_2Te

- (a) lowest boiling point
(b) highest bond angle
(c) highest electropositive hydrogen.
7. (i) How is XeO_3 prepared from XeF_6 ? Write the chemical equation for the reaction.
(ii) Draw the structure of XeF_4 .
8. (i) Thermal stability of hydrides of group 16 elements decreases down the group. Why?
(ii) Compare the oxidising powers of F_2 and Cl_2 on the basis of bond dissociation enthalpy, electron gain enthalpy of halogens and hydration enthalpy of halide ions.
(iii) Write the chemical equation for the reaction of copper metal with conc. HNO_3 .
- *9. An unknown salt X reacts with hot conc. H_2SO_4 to produce a brown coloured gas which intensifies on addition on copper turnings. On adding dilute ferrous sulphate solution to an aqueous solution of X and then carefully adding conc. H_2SO_4 along the sides of the test tube, a brown complex Y is formed at the interface between the solution and H_2SO_4 . Identify X and Y and write the chemical equation involved in the reaction.
[Hint : X is NO_3^- salt].
10. Assign reason to the following :
(i) Noble gases have large positive values of electron gain enthalpy.
(ii) Helium is used by scuba divers.
11. Arrange the following in the order of the property indicated for each set—
(a) F_2 , Cl_2 , Br_2 , I_2 (Increasing bond dissociation energy).
(b) HF , HCl , HBr , HI (decreasing acid strength).
(c) NH_3 , PH_3 , AsH_3 , SbH_3 , BiH_3 (decreasing base strength).

[Hint :

- (a) F_2 has exceptionally low bond dissociation enthalpy. Lone pairs in F_2 molecule are much closer to each other than in Cl_2 molecule. Larger electron–electron repulsions among the lone pairs in F_2 molecule make its bond dissociation enthalpy exceptionally low.
(b) Depends upon H–X bond dissociation enthalpy as the size of atom increases, bond dissociation enthalpy of H–X decreases.

- (c) Electron availability on the central atom 'E' in EH_3 decreases down the group.
- *12. A translucent white waxy solid (A) on heating in an inert atmosphere is converted to its allotropic form (B), Allotrope (A) on reaction with very dilute aqueous NaOH liberates a highly poisonous gas (C) having a rotten fish smell, with excess of chlorine forms D which hydrolyses to form compound (E). Identify the compounds (A) to (E).
- A : White phosphorus, B : Red phosphorus, C : PH_3 , D : PCl_3 , E : H_3PO_4
13. Write balanced equation for the following reactions :
- Zn is treated with dilute HNO_3 .
 - NaCl is heated with H_2SO_4 in the presence of MnO_2 .
 - Iodine is treated with conc. HNO_3 .
14. X_2 is a greenish yellow gas with pungent offensive smell used in purification of water. It partially dissolves in H_2O to give a solution which turns blue litmus red. When X_2 is passed through NaBr Solution, Br_2 is obtained.
- Identify X_2 , name the group to which it belongs.
 - What are the products obtained when X_2 reacts with H_2O ? Write chemical equation.
 - What happens when X_2 reacts with hot and conc. NaOH? Give equation.
16. Assign the appropriate reason for the following:
- Nitrogen exists as diatomic molecule and phosphorous as P_4 , Why?
 - Why does $\text{R}_3\text{P} = \text{O}$ exist but $\text{R}_3\text{N} = \text{O}$ does not ? (R = an alkyl group).
 - Explain why fluorine forms only one oxoacid, HOF.

[Hint :

- Due to its small size and high electronegativity N forms $p\pi - p\pi$ multiple bond ($\text{N} \equiv \text{N}$). whereas P does not form $p_\pi - p_\pi$ bonds but forms P - P single bond.
- Due to the absence of d-orbitals, N cannot expand its covalence beyond four.

In $\text{R}_3\text{N} = \text{O}$, N should have a covalence of 5 so the compound $\text{R}_3\text{N} = \text{O}$ does not exist since maximum covalence shown by N cannot exceed 4.

- (c) F does not form oxoacids in which the oxidation state of F would be +3, +5, +7, it forms one oxoacid, because of unavailability of d orbitals in its valence shell.

LONG ANSWER TYPE QUESTIONS (5 - MARK QUESTIONS)

- How is PH_3 prepared in the laboratory? How is it purified? How does the solution of PH_3 in water react on irradiation with light and on absorption in CuSO_4 ? How can you prove that PH_3 is basic in nature?
Write the chemical equations for all the reactions involved.
- Assign a possible reason for the following :
 - Stability of +5 oxidation state decreases and that of +3 oxidation state increases down the group 15 elements.
 - H_2O is less acidic than H_2S .
 - SF_6 is inert while SF_4 is highly reactive towards hydrolysis.
 - H_3PO_2 and H_3PO_3 act as good reducing agents while H_3PO_4 does not.
 - Noble gases have comparatively large size in their respective periods.
- How is XeF_6 prepared from the XeF_4 ? Write the chemical equation for the reaction.
 - Deduce the structure of XeF_6 using VSEPR theory.
 - How does XeF_2 reacts with PF_5 ?
 - Give one use each of helium and neon.
 - Write the chemical equation for the hydrolysis of XeF_4 .
- Why does nitrogen show anomalous behaviour? Discuss the trend of chemical reactivity of group 15 elements with.
 - oxygen
 - halogens
 - metals
 - H_3PO_3 is a dibasic acid. Why?
- Arrange the following in the order of their increasing acid strength.
 - Cl_2O_7 , SO_2 , P_4O_{10}
 - How is N_2O gas prepared? And draw its structure.
 - Give one chemical reaction to show O_3 is an oxidising agent.

*6. Identify A, B, C, D and E in the following sequence of reactions

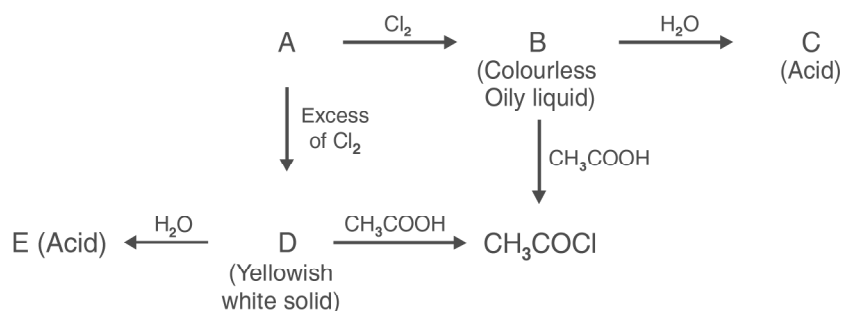

Complete the reactions of the above mentioned sequence.

[Hint : A is P₄].

*7. A white waxy, translucent solid, M, insoluble in water but soluble in CS₂, glows in dark. M dissolves in NaOH in an inert atmosphere giving a poisonous gas (N). Also M catches fire to give dense white fumes of Q :

- Identify M, N and Q and write the chemical equations of the reactions involved.
- M exists in the form of discrete tetrahedral molecules. Draw its structure.
- M on heating at 573 K is changed into other less reactive form, Q, which is non-poisonous, insoluble in water as well as in CS₂ and does not glow in dark, Identify Q and draw its structure.

8. Write the structure of A, B, C, D and E in the following sequence of reactions :

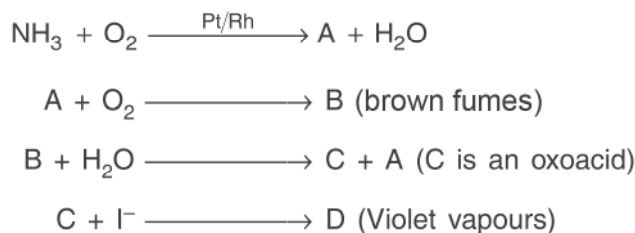

Complete reactions of the above mentioned sequence and name the process by which 'C' is obtained.

[Hint. : A is NO and Ostwald process for the manufacture of HNO₃].

9. Give reason for each of the following :
- (a) NH_3 is more basic than PH_3 .
 - (b) Ammonia is a good complexing agent.
 - (c) Bleaching by SO_2 is temporary.
 - (d) PCl_5 is ionic in solid state.
 - (e) Sulphur in vapour state exhibits paramagnetism.
10. Knowing the electrons gain enthalpy value for $\text{O} \rightarrow \text{O}^-$ and $\text{O}^- \rightarrow \text{O}^{2-}$ as -141 and 720 kJ mol^{-1} respectively, how can you account for the formation of large number of oxides having O^{2-} species and not O^- ?
- [Hint :** Latice enthalpy of formation of oxides having O^{2-} more than compensates the second $\Delta_{\text{eg}}\text{H}$ of oxygen.

KRISHNA
PUBLIC SCHOOL

d – AND f – BLOCK ELEMENTS

Electronic Configuration of Transition Metal/Ions

The d-block element is called transition metal if it has partly filled d-orbitals in the ground state as well as in its oxidised state.

The general electronic configuration of transition metal is $(n-1) d^{1-10} ns^{1-2}$. Exceptions in electronic configuration are due to (a) very little energy difference between $(n-1) d$ and ns orbitals and (b) extra stability of half filled and completely filled orbitals in case of Cr and Cu in 3d series.

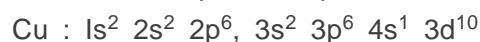
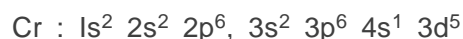

To write the electronic configuration of M^{n+} , the electrons are first removed from ns orbital and then from $(n - 1) d$ orbitals of neutral, atom (if required). For example, the electronic configuration of Cu^+ , Cu^{2+} and Cr^{3+} are respectively $3d^{10} 4s^0$, $3d^9 4s^0$ and $3d^3 4s^0$.

The following questions can be answered with the help of above.

- Scandium ($Z = 21$) is a transition element but zinc ($Z = 30$) is not.
- Copper ($Z = 29$) and silver ($Z = 47$) both have fully filled d-orbitals i.e., $(n - 1) d^{10}$. why are these elements are regarded as transition elements?
- Which of the d-block elements are not regarded as transition elements?

UNDERSTANDING $\Delta_{\text{fus}} H^\theta$, $\Delta_{\text{vap}} H^\theta$, AND $\Delta_a H^\theta$

In transition metals unpaired $(n - 1)d$ electrons as well as ns electrons take part in interatomic bonding. Larger the number of unpaired $(n - 1) d$ electrons, the stronger is the interatomic bonding and large amount of energy is required to overcome the interatomic interaction.

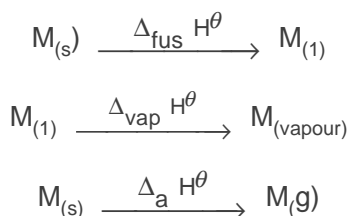

These enthalpies are related as

$$\Delta_{\text{fus}} H^\theta < \Delta_{\text{vap}} H^\theta < \Delta_a H^\theta$$

The following questions can be explained using the above reasoning.

- (i) Which has higher m.p.? V (Z = 23) or Cr (Z = 24) ?
- (ii) Explain why Fe (Z = 26) has higher m.p. than cobalt (Z = 27).

Metals of second (4d) and third (5d) transition series have greater enthalpies of atomisation than corresponding elements of first transition series on account of more frequent metal metal bonding due to greater spatial extension of 4d and 5d orbitals than 3d orbitals.

LANTHANOID CONTRACTION AND ITS CONSEQUENCE

The 4f orbitals screen the nuclear charge less effectively because they are large and diffused. The filling of 4f orbitals before 5d orbitals results in the gradual increase in effective nuclear charge resulting in a regular decrease in atomic and ionic radii. This phenomenon is called lanthanoid contraction. The corresponding members of second and third transition series have similar radii because the normal size increase down the group of d-block elements almost exactly balanced by the lanthanoid contraction.

This reasoning is applied in answering the following questions.

- (i) Elements in the following pairs have identical (similar) radii : Zr/Hf, Nb/Ta and Mo/W. Explain why?
- (ii) Why do Zr and Hf have very similar physical and chemical properties and occur together in the same mineral?

VARIATION IN IONISATION ENTHALPY

With the filling of (n - 1) d orbitals effective nuclear charge increases resulting in the increase in first ionisation enthalpy. There are some irregular variations.

The first ionisation enthalpy of chromium is lower because the removal of one electron produces extra stable d^5 configuration and that of zinc is higher because the removal of electron takes place from fully filled 4s orbital.

Second ionization enthalpy of Zn ($\Delta_i H_2 = 1734$ kJ/mol) is lower than second ionization enthalpy of Cu (1958 kJ/mol). This is because removal of second electron in Zn produces stable d^{10} configuration while the removal of second electron in Cu disrupts the d^{10} configuration with a considerable loss in exchange energy to form less stable d^9 configuration.

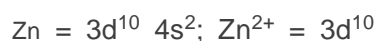

Now the following questions can be accounted for :

- (i) Why is second ionization enthalpy of Cr (Z = 24) more than that Mn (Z = 25) (Hint. Cr^+ ($d^5 \rightarrow d^4$), Mn^+ ($3d^5 4s^1 \rightarrow 3d^5$)).
- (ii) Which has more second ionisation enthalpy?
Cu (Z = 29) or Zn (Z = 30) (Hint. Cu^+ ($d^{10} \rightarrow d^9$), Zn^+ ($3d^{10} 4s^1 \rightarrow 3d^{10}$)).
- (iii) Second ionization enthalpy of Mn (Z = 25) is less than that of Fe (Z=26) but third ionisation enthalpy of Mn is more than that of Fe. Why?

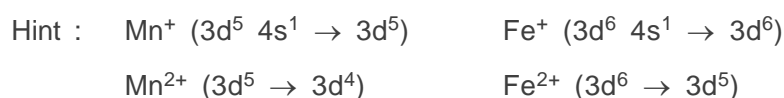

Relationship between E_{red}^\ominus and stability of various oxidation states.

Transition metals show variable oxidation states due to incompletely filled d-orbitals. These variable oxidation states differ from each other by unity, e.g., Mn (II), Mn (III), Mn (IV), Mn (V), Mn (VI) and M (VII). Scandium is the only transition element which exclusively shows the oxidation state of +3.

Standard Electrode potential $E_{\text{M}^{2+}/\text{M}}^\ominus$ can be calculated from the following parameters :

The reducing property of a transition metal will be higher if $\Delta_r H^\ominus$ has a large negative value which is possible if $\Delta_{\text{hyd}} H^\ominus$ more than compensates ($\Delta_a H^\ominus + \Delta_a H_1 + \Delta_i H_1 + \Delta_i H_2$).

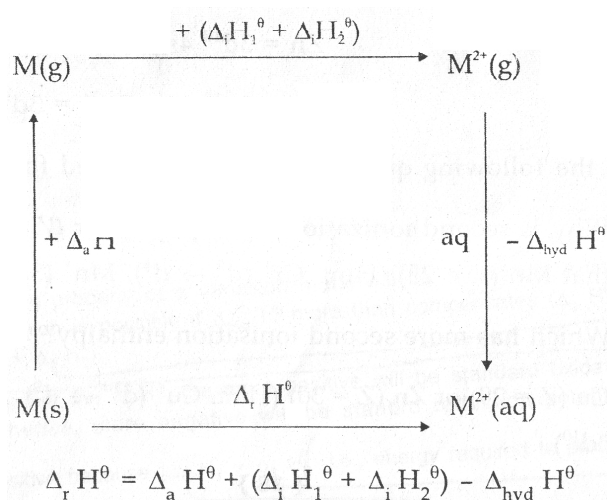

More negative the $\Delta_r H^\theta$, the more positive will be standard oxidation potential and hence, more negative will be standard reduction potential. $E^\ominus_{\text{Cu}^{2+}/\text{Cu}}$ is positive because $(\Delta_i H_1 + \Delta_i H_2)$ i.e., energy required to produce Cu^{2+} is not balanced by $\Delta_{\text{hyd}} H^\theta$ of Cu^{2+} .

Since the sum of $\Delta_i H_1$ and $\Delta_i H_2$ generally increases with the increase in the atomic number of the transition metal, therefore $E^\ominus_{\text{M}^{2+}/\text{M}}$ value becomes less and less negative.

$E^\ominus_{\text{M}^{2+}/\text{M}}$ values for Mn, Zn and Ni are more negative than expected trend. This is because $\Delta_i H_2$ for Mn and Zn produces stable d^5 configuration (Mn^{2+}) and d^{10} configuration (Zn^{2+}) are produced and therefore requirement of energy is less.

whereas $E^\ominus_{\text{Ni}^{2+}/\text{Ni}}$ is more negative due to highest negative $\Delta_{\text{hyd}} H^\theta$ which is -2121 kJ/mol for Ni^{2+} .

Example : Why is E^\ominus value for $\text{Mn}^{3+} / \text{Mn}^{2+}$ couple much more positive than for $\text{Cr}^{3+} / \text{Cr}^{2+}$ or $\text{Fe}^{3+} / \text{Fe}^{2+}$.

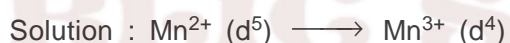

has much larger third ionisation energy due to disruption of extrastability of half filled d^5 configuration.



Cr^{3+} has half-filled t_{2g} level. Hence Cr^{2+} is oxidised easily to stable Cr^{3+} ion. Hence E^\ominus value is comparatively less.



Comparatively low value of E^\ominus is also due to extra stability of d^5 configuration of Fe^{3+} .

Example : Which is stronger reducing agent Cr^{2+} or Fe^{2+} and why?

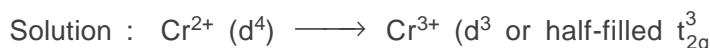

In water medium $[\text{Cr} (\text{H}_2\text{O})_6]^{3+}$ has more CFSE than $[\text{Fe} (\text{H}_2\text{O})_6]^{3+}$. Hence Cr^{2+} is a stronger reducing agent.

Stability of Higher Oxidation States :

Higher oxidation states are shown by transition metals in fluorides, oxides, oxocations and oxoanions. The ability of fluorine to stabilise the highest oxidation state is due to either higher lattice energy as in case of CoF_3 or higher bond enthalpy terms for higher covalent compounds, e.g., VF_5 and CrF_6 .

Transition metals show highest oxidation state in oxides and oxocations and oxoanions, e.g., VO_4^+ and VO_4^- . The ability of oxygen to stabilise these high oxidation states exceeds that of fluorine due to its ability to form multiple bonds to metals.

The following questions can be explained using the above concepts.

- (i) All Cu (II) halides are known except the iodides. Why?



- (ii) Why do Cu (I) compounds undergo disproportionation in water?

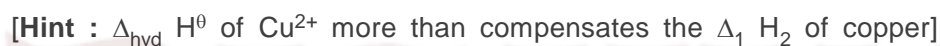

- (iii) Highest fluoride of Mn is MnF_4 but the highest oxide is Mn_2O_7 .

- (iv) E^\ominus values of 3d series varies irregularly.

- (v) Why is Cr^{2+} is reducing and Mn^{3+} oxidising when both have d^4 configuration?

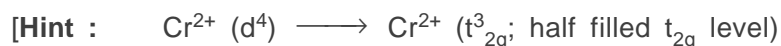

- (vi) Why is highest oxidation state shown in oxocations and oxoanions?

Properties of Transition Elements

Transition metals with partly filled d-orbitals exhibit certain characteristic properties. For example they display a variety of oxidation states, form coloured ions and enter into complex formation. Transition metals and their compounds exhibit catalytic properties and are generally paramagnetic in nature.

Crystal Field Theory :

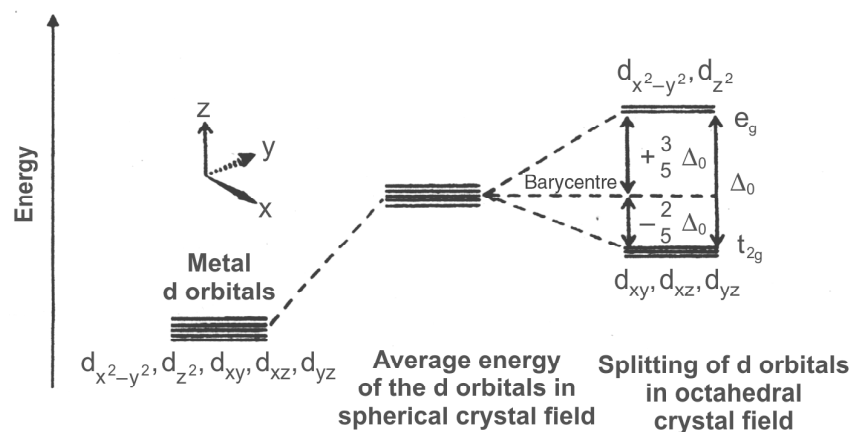

d orbitals splitting in an octahedral crystal-field

Calculation of CFSE : Each electron occupying t_{2g} orbital results in the lowering of energy by $-0.40 \Delta_0$ and each electron occupying the e_g orbital increases the energy by $+0.60 \Delta_0$. If x is the no. of electrons occupying t_{2g} orbitals and ' y ' is the no. of electrons occupying the e_g orbitals, then CFSE is given by

$$\begin{aligned} \text{CFSE} &= (-0.40 \Delta_0 x + 0.60 \Delta_0 y) \\ &= (-0.40 x + 0.60 y) \Delta_0 \end{aligned}$$

Formation of Coloured Ions : Degeneracy of d-orbitals is lifted in presence of the field of ligands approaching the central metal ion. For example, in the octahedral crystal field of ligands, the d-orbitals are split into two set of d-orbitals (i) t_{2g} orbitals of lower energy : these are d_{xy} , d_{yz} , d_{xz} and (ii) e_g orbitals of higher energy i.e., $d_{x^2-y^2}$ and d_{z^2} .

When visible light is incident on the octahedral transition metal complex, an electron is excited from t_{2g} level to e_g level. During this d-d transition, a characteristic wave length of visible light is absorbed and therefore transmitted light appears coloured. The colour of complex is complementary to the colour absorbed by the transition metal complex.

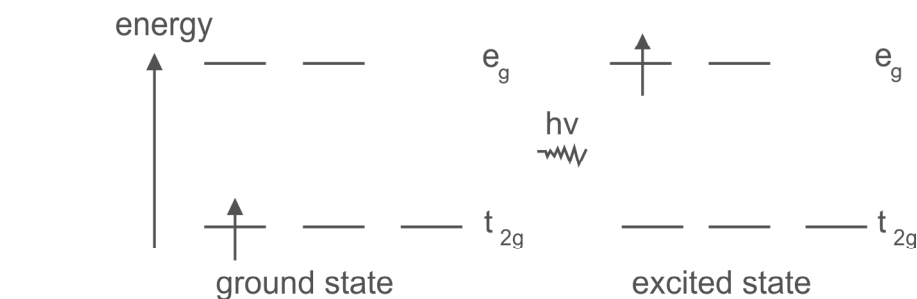

Oxidation States of Lanthanoids and Actinoids

The most common and most stable oxidation state of lanthanoids is +3. They also show oxidation states of +2, and +4 if the corresponding lanthanoid ions have extra stable $4f^0$, $4f^7$ and $4f^{14}$ configuration.



Hence Ce^{4+} and Tb^{4+} are strong oxidants.



Hence, Eu^{2+} and Yb^{2+} are strong reducing agents.

Actinoids also show most common O.S. of + 3 but it is not always most stable. Actinoids also show higher oxidation states, e.g., Th (+4), Pa (+5), U (+ 6) and Np (+ 7).

Example : La ($5d^16s^2$), Gd ($4f^75d^16s^2$) and Lu ($4f^{14} 5d^16s^2$) have abnormally low third ionisation enthalpies. Why?

Solution : La^{3+} , Gd^{3+} and Lu^{3+} have stable configurations $4f^0$, $4f^7$ and $4f^{14}$ respectively.

Answer the following question –

- (i) Name the two members of lanthanoid series which show + 2 oxidation state
- (ii) Name the lanthanoid element which shows +4 O.S.

Participation of 5f electrons of actinoids in bonding.

5f orbitals in actinoids are not as buried as 4f orbitals in lanthanoids and hence 5f electrons can participate in bonding to a far greater extent.

There is a gradual decrease in the size of atoms or M^{3+} ions across the actinoid series. Since 5f orbitals are larger and more diffuse than 4f orbitals, their penetration towards the inner core of electrons is less than the penetration of 4f electrons. Hence 5f electrons screen the nuclear charge less effectively than 4f electrons in lanthanoids. Consequently effective nuclear charge in actinoids increases at faster rate as compared with lanthanoids. Hence actinoid contraction from element to element is more than the lanthanoid contraction.

The following question can be explained with the above reasoning :

Explain why Actinoid contraction from element to element is greater than lanthanoid contraction.

VERY SHORT ANSWER TYPE QUESTIONS

(1 - MARK QUESTIONS)

1. Write the electronic configuration of Cr^{3+} ion (atomic number of Cr = 24)?
3. Explain $\text{CuSO}_4 \cdot 5\text{H}_2\text{O}$ is blue while ZnSO_4 and CuSO_4 are colourless?
4. Why is the third ionisation energy of Manganese ($Z = 25$) is unexpectedly high?

[Hint : The third electron is to be removed from stable configuration Mn^{2+} ($3d^5$). It requires higher energy.]

5. Which element among 3d- transition elements, exhibit the highest oxidation state?

[Hint : Mn (+7)]

6. Silver (Ag) has completely filled d-orbitals ($4d^{10}$) in its ground state. How can you say that it is a transition element.
7. In 3d series ($\text{Sc} \rightarrow \text{Zn}$), the enthalpy of atomisation of Zn is low. Why?

[Hint : Poor interatomic bonding in zinc.]

8. Out of the following elements, identify the element which does not exhibit variable oxidation state?

Cr, Co, Zn.

9. The +3 oxidation state of lanthanum ($Z = 57$), gadolinium ($Z = 64$) and lutetium ($Z = 71$) are especially stable. Why?
10. Mention one consequence of Lanthanoid Contraction?
11. The first ionization enthalpies of 5d- series elements is higher than those of 3d and 4d series elements why?

[Hint : Increasing value of effective nuclear charge due to lanthanoid contraction.]

12. Why Mn^{2+} compounds are more stable than Fe^{2+} compounds towards oxidation to their +3 state?

14. Calculate the magnetic moment of Cu^{2+} ($Z = 29$) on the basis of “spin-only” formula.

[Hint : $\mu = \sqrt{n(n+2)}$ B.M.]

15. What is the shape of chromate ions?

[Hint : Tetrahedral]

16. Why does vanadium pentoxide act a catalyst?

[Hint : In V_2O_5 , Vanadium shows variable oxidation sates.]

17. What are interstitial compounds?

18. The transition metals and their compounds are known for their catalytic activity. Give two specific reasons to justify the statement.

19. Write the chemical equation for the reaction of thiosulphate ions and alkaline potassium permanganate.

[Hint : $8\text{MnO}_4^- + 3\text{S}_2\text{O}_3^{2-} + \text{H}_2\text{O} \rightarrow 8\text{MnO}_2 + 2\text{OH}^- + 6\text{SO}_4^{2-}$].

20. Mention the name and formula of the ore from which potassium dichromate is prepared.

[Hint : FeCr_2O_4 (Chromite)].

21. Write the electronic configuration of Lu^{3+} (At. No. = 71).

22. What is the most common oxidation state of actinoids?

23. Write the names of the catalyst used in the :

- (a) Manufacture of sulphuric acid by contact process.
(b) Manufacture of polythene.

24. Mention the name of the element among lanthanoids known to exhibit +4 oxidation state.

25. Name one ore each of manganese and chromium.

26. Why is Cd^{2+} ion white?

- *27. Draw the structure of dichromate anion.

- *28. Arrange the following monoxides of transition metals on the basis of decreasing basic character TiO , VO , CrO , FeO . [Hint : $\text{TiO} > \text{VO} > \text{CrO} > \text{FeO}$]

SHORT ANSWER TYPE QUESTIONS (2 - MARK QUESTIONS)

- Write the chemical equation, when the yellow colour of aqueous solution of Na_2CrO_4 changes to orange on passing CO_2 gas?
- The stability of Cu^{2+} (aq) is more than that of Cu^+ (aq). Why?
- Indicate the steps in the preparation of
 - $\text{K}_2\text{Cr}_2\text{O}_7$ from Chromite ore.
 - KMnO_4 from Pyrolusite ore.
- Give reason for : –
 - In permanganate ions, all bonds formed between manganese and oxygen are covalent.
 - Permanganate titrations in presence of hydrochloric acid are unsatisfactory.
- Write complete chemical equations for
 - oxidation of Fe^{2+} by $\text{Cr}_2\text{O}_7^{2-}$ in acidic medium
 - oxidation of Mn^{2+} by MnO_4^- in neutral or faintly alkaline medium.
- Why do transition metals show high melting points?
 - Out of Fe and Cu, which one would exhibit higher melting point?

[Hint. (i) Strong interatomic bonding arising from the participation of ns and unpaired $(n - 1) d$ -electrons.

(ii) Fe has higher melting point due to presence of more unpaired electrons $3d$ -orbitals.
- Describe giving reason which one of the following pairs has the property indicated :
 - Cr^{2+} or Fe^{2+} (stronger reducing agent).
 - Co^{2+} or Ni^{2+} (lower magnetic moments).
- Of the ions Co^{2+} , Sc^{3+} , Cr^{3+} which one will give colourless aqueous solution and how will each of them respond to magnetic field and why?

[Hint : Co^{2+} ($3d^7$); Cr^{3+} ($3d^4$); Sc^{3+} ($3d^0$)]
- Complete the following equations :
 - $\text{MnO}_2 + \text{KOH} + \text{O}_2 \longrightarrow$
 - $\text{Na}_2\text{Cr}_2\text{O}_7 + \text{KCl} \longrightarrow$

10. Transition metals show low oxidation states with carbon monoxide.

[Hint : CO is a π acceptor ligand capable of forming a π bond by accepting π electrons from the filled d-orbitals of transition metal and CO also form σ bond by donating σ electrons to transition metal orbital.

11. For the first row transition metals the enthalpy of atomisation value are :

	Sc	Ti	V	Cr	Mn	Fe	Co	Ni	Cu	Zn
$\Delta_a H^\ominus / \text{kJ mol}^{-1}$	326	473	515	397	281	416	425	430	339	26

Assign reason for the following :

- (a) Transition elements have higher values of enthalpies of atomisation.
(b) The enthalpy of atomisation of zinc is the lowest in 3d - series.
12. Account for the following :
- (a) Copper shows its inability to liberate hydrogen gas from the dilute acids.
(b) Scandium (Z = 21) does not exhibit variable oxidation states.
13. Copper (I) compounds undergo disproportionation. Write the chemical equation for the reaction involved and give reason.
14. Iron (III) catalyses the reaction :

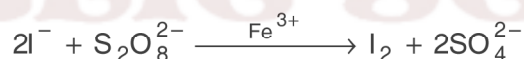

15. Complete the equations :

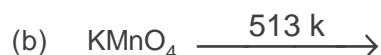

16. The following two reactions of MnO_3 with Zn are given.



Identify X and Y and write balanced equations.

[Hint : X is NO_2 and Y is N_2O].

17. Titanium shows magnetic moment of 1.73 BM in its compound. What is the oxidation number of Ti in the compound?

[Hint : O.N. of Ti = +3].

18. Account for the following :

(a) Transition metals and majority of their compounds act as good catalysts.

(b) From element to element, actinoid contraction is greater than lanthanoid contraction

19. Calculate the number of electrons transferred in each case when KMnO_4 acts as an oxidising agent to give

(i) MnO_2 (ii) Mn^{2+} (iii) $\text{Mn}(\text{OH})_3$ (iv) MnO_4^{2-} respectively.

[Hint : 3, 5, 4, 1].]

20. Calculate the number of moles of KMnO_4 that is needed to react completely with one mole of sulphite ion in acidic medium.

[Hint : 2/5 moles].

SHORT ANSWER TYPE QUESTIONS (3 - MARK QUESTIONS)

1. Account for the following :

(a) $\text{La}(\text{OH})_3$ is more basic than $\text{Lu}(\text{OH})_3$

(b) Zn^{2+} salts are white.

(c) $\text{Cu}(\text{I})$ compounds are unstable in aqueous solution and undergo disproportionation.

2. Describe the oxidising action of potassium dichromate with following. Write ionic equations for its reaction with.

(a) Iodide ion (b) Iron (II) (c) H_2S .

3. (a) Deduce the number of 3d electrons in the following ions : Fe^{3+} , Cu^{2+} and Sc^{3+} .

(b) Why do transition metals form alloys.

(c) Write any two characteristics of interstitial compounds.

- *4. In the following reaction, Mn(VI) changes to Mn(VII) and Mn(IV) in acidic solution.



- (a) Explain why Mn(VI) changes to Mn(VII) and Mn(IV).
 (b) What special name is given to such type of reactions?
5. What happens when
 (a) thiosulphate ions react with alkaline KMnO_4 .
 (b) ferrous oxalate reacts with acidified KMnO_4 .
 (c) sulphurous acid reacts with acidified KMnO_4

Write the chemical equations for the reactions involved.

7. Name the catalysts used in the
 (a) manufacture of ammonia by Haber's Process
 (b) oxidation of ethyne to ethanol
 (c) photographic industry.

- *8. Among TiCl_4 , VCl_3 and FeCl_2 which one will be drawn more strongly into a magnetic field and why?

[Hint : Among these halides the transition metal ion having maximum number of unpaired electrons will be drawn strongly into the magnetic field.

$\text{Ti}^{4+} = 3d^0$	no. of unpaired $e^- = 0$	$\mu = 0$
$\text{V}^{3+} = 3d^2$	no. of unpaired $e^- = 2$	$\mu = 2.76 \text{ BM}$
$\text{Fe}^{2+} = 3d^6$	no. of unpaired $e^- = 4$	$\mu = 4.9 \text{ BM}$

9. Complete the following equations

- (a) $\text{MnO}_4^{2-} + \text{H}^+ \longrightarrow \dots\dots + \dots\dots + \dots\dots$
 (b) $\text{KMnO}_4 \xrightarrow{\text{Heat}}$
 (c) $\text{H}^+ + \text{MnO}_4^- + \text{Fe}^{2+} + \text{C}_2\text{O}_4^{2-} \longrightarrow$

10. How do you account for the following?

- (a) With the same d-orbital configuration (d^4), Cr^{2+} is a reducing agent while Mn^{3+} is an oxidising agent.
 (b) The actinoids exhibit a larger number of oxidation states than the corresponding members in the lanthanoid series.
 (c) Most of transition metal ions exhibit characteristic colours in aqueous solutions.

LONG ANSWER TYPE QUESTIONS (5 - MARK QUESTIONS)

1. A green compound 'A' on fusion with NaOH in presence of air forms yellow compound 'B' which on acidification with dilute acid, gives orange solution of compound 'C'. The orange solution when reacted with equimolar ammonium salt gives compound 'D' which when heated liberates nitrogen gas and compound 'A'. Identify compounds A to D and write the chemical equation of the reactions involved.

[Hint : 'A' = CrO_3 ; 'B' = Na_2CrO_4 ; 'C' = $\text{Na}_2\text{Cr}_2\text{O}_7$ 'D' = $(\text{NH}_4)_2\text{Cr}_2\text{O}_7$

2. Assign reasons for the following :
- There is no regular trends in E° values of M^{2+}/M systems in 3d series.
 - There is gradual decrease in the ionic radii of M^{2+} ion in 3d series.
 - Majority of transition metals form complexes.
 - Ce^{3+} can be easily oxidised to Ce^{4+}
 - Tantalum and palladium metals are used to electroplate coinage metals.
3. Account for the following :
- Actinoids display a variety of oxidation states.
 - Yb^{2+} behaves as a good reductant.
 - Cerium (iv) is a good analytical reagent.
 - Transition metal fluorides are ionic in nature while chlorides and bromides are covalent in nature.
 - Hydrochloric acid attacks all the actinoids.
- *4. Explain by giving suitable reason :
- Co(II) is stable in aqueous solution but in the presence of complexing agent it is readily oxidised.
 - Eu^{2+} , Yb^{2+} are good reductants whereas Tb^{4+} is an oxidant.
 - AgCl dissolves in ammonia solution
 - Out of Cr^{2+} or Fe^{2+} , which one is a stronger reducing agent?
 - The highest oxidation state is exhibited in oxoanions of a transition metal.

5. When a white crystalline compound A is heated with $K_2Cr_2O_7$ and conc. H_2SO_4 , a reddish brown gas B is evolved, which gives a yellow coloured solution C when passed through NaOH. On adding CH_3COOH and $(CH_3COO)_2Pb$ to solution C, a yellow coloured ppt. D is obtained. Also on heating A with NaOH and passing the evolved gas through K_2HgI_4 solution, a reddish brown precipitate E is formed.

Identify A, B, C, D and E and write the chemical equations for the reactions involved.

[Hint : (A) NH_4Cl , (B) CrO_2Cl_2 (g), (C) Na_2CrO_4

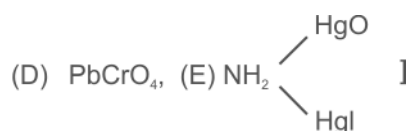

- *6. (a) Describe the preparation of potassium dichromate ($K_2Cr_2O_7$). Write the chemical equations of the reactions involved.
- (b) "The chromates and dichromates are interconvertible by the change in pH of medium." Why? Give chemical equations in favour of your answer.
7. Explain giving reasons :
- (a) Transition metals are less reactive than the alkali metals and alkaline earth metals.
- (b) $E^\ominus_{Cu^{2+}/Cu}$ has positive value
- (c) Elements in the middle of transition series have higher melting points.
- (d) The decrease in atomic size of transition elements in a series is very small.
8. (a) Compare the chemistry of the actinoids with that of lanthanoids with reference to—
- (i) electronic configuration
- (ii) oxidation states
- (iii) chemical reactivity.

- (b) How would you account for the following :
- of the d^4 species, Cr^{2+} is strongly reducing while Mn^{3+} is strongly oxidising.
 - the lowest oxide of a transition metal is basic whereas highest is amphoteric or acidic.
9. (a) What is meant by disproportionation of an oxidation state. Give one example.
- (b) Explain why europium (II) is more stable than Ce(II)?

[Hint : (a) When particular state becomes less stable relative to other oxidation states, one lower and one higher, it is said to undergo disproportionation, for example,

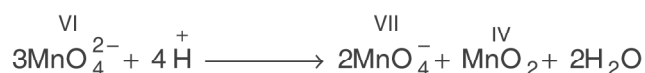

- (b) Eu (II) = $[\text{Xe}] 4f^7 5d^0$ (4f subshell is half filled)
 Ce (II) = $[\text{Xe}] 4f^1 5d^0$ (5d Subshell is empty and 4f subshell has only one electron which can be easily lost.)
10. (a) For M^{2+}/M and $\text{M}^{3+}/\text{M}^{2+}$ systems, the E^\ominus values for some metals are as follows :
- $\text{Cr}^{2+}/\text{Cr} = -0.9\text{V}$ and $\text{Cr}^{3+}/\text{Cr}^{2+} = -0.4\text{V}$
 $\text{Mn}^{2+}/\text{Mn} = -1.2\text{V}$ and $\text{Mn}^{3+}/\text{Mn}^{2+} = +1.5\text{V}$
 $\text{Fe}^{2+}/\text{Fe} = -0.4\text{V}$ and $\text{Fe}^{3+}/\text{Fe}^{2+} = +0.8\text{V}$
- Use this data to comment upon :
- the stability of Fe^{3+} in acid solution as compared to that of Cr^{3+} and Mn^{3+}
 - the ease with which iron can be oxidised as compared to a similar process for either chromium or manganese.
- (b) How is the variability in oxidation states of transition metals different from that of the non-transition metals? Illustrate with examples.

Unit - 9

CO-ORDINATION COMPOUNDS

QUESTIONS

VSA QUESTIONS (1 - MARK QUESTIONS)

1. Define the term coordination compound?
2. Write the names of counter ions in
(i) $\text{Hg} [\text{Co} (\text{SCN})_4]$ and (ii) $[\text{Pt}(\text{NH}_3)_4] \text{Cl}_2$.
3. Write the oxidation state of nickel in $[\text{Ni}(\text{CO})_4]$
- *4. What is the coordination number of central atom in $[\text{Co}(\text{C}_2\text{O}_4)_3]^{3-}$?
[Ans. : 6]
5. What is the coordination number of iron in $[\text{Fe} (\text{EDTA})]^-$? [Ans. : 6]
6. Write the name of a complex compound used in chemotherapy.
[Ans. : Cis-Platin. $[\text{Pt}(\text{NH}_3)_2 \text{Cl}_2]$
7. Name the compound used to estimate the hardness of water volumetrically.
8. Give the IUPAC name of $[\text{Pt} \text{Cl}_2 (\text{NH}_2\text{CH}_3) (\text{NH}_3)_2] \text{Cl}$.
- *9. How many geometrical isomers are possible for the tetrahedral complex $[\text{Ni}(\text{CO})_4]$.
[Ans. : No isomer, as the relative positions of the unidentate ligands attached to the central metal atom are same with respect to each other].
10. Arrange the following in the increasing order of conductivity in solution.
 $[\text{Ni}(\text{NH}_3)_6]\text{Cl}_2$; $[\text{Co}(\text{NH}_3)_6]\text{Cl}_3$ and $[\text{CoCl}_2(\text{en})_2] \text{Cl}$
11. Arrange the following ligands in increasing order of Δ_o (Crystal field splitting energy) for octahedral complexes with a particular metal ion.
 Cl^- , NH_3 , I^- , CO , en .

12. Write I.U.P.A.C. name of Tollens' reagent.
13. Which is more stable? $K_3[Fe(CN)_6]$ or $K_4[Fe(CN)_6]$
14. Calculate the overall dissociation equilibrium constant for the $[Cu(NH_3)_4]^{2+}$ ion. Given that overall stability constant (β_4) for this complex is 2.1×10^{13} .
[Ans. : 4.7×10^{-14}]
- *15. What is a chelate ligand? Give one example.
16. Write the I.U.P.A.C. name of $Li[AlH_4]$.
17. Name one homogeneous catalyst used in hydrogenation of alkenes.
- *18. Name the types of isomerism shown by coordination entity : $[CrCl_2(Ox)_2]^{3-}$
- *19. $[Ti(H_2O)_6]Cl_3$ is coloured but on heating becomes colourless. Why?
- *20. Write the IUPAC name of ionization isomer of $[Co(NH_3)_5(SO_4)] Br$
- *21. Write the formula and the name of the coordinate isomer of $[Co(en)_3][Cr(CN)_6]$.
[Ans. : $[Cr(en)_3][Co(CN)_6]$ Tris- (ethane -1, 2, diammine) chromium (III) hexacyanocobaltate (III)]

SA(I) TYPE QUESTIONS (2 - MARK QUESTIONS)

- *22. Write two differences between a double salt and a coordination compound with the help of an example of each.
23. Mention the main postulates of Werner's Theory.
24. Define (a) Homoleptic and (b) Heteroleptic complexes with the help of one example of each.
25. In the following coordination entity : $[Cu(en)_2]^{2+}$
- Identify the ligand involved and
 - Oxidation state of copper metal.
27. Calculate the magnetic moments of the following complexes :
- $[Fe(CN)_6]^{4-}$
 - $[CoF_6]^{3-}$
28. Explain the following :
- $[Fe(CN)_6]^{3-}$ is an inner orbital complex whereas $[FeF_6]^{3-}$ is an outer orbital complex.
 - NH_3 acts as complexing agent but NH_4^+ does not.

29. What type of structural isomerism is represented by the following complexes:
- (a) $[\text{Mn}(\text{CO})_5(\text{SCN})]$ and $[\text{Mn}(\text{CO})_5(\text{NCS})]$
- (b) $[\text{Co}(\text{NH}_3)_5(\text{NO}_3)] \text{SO}_4$
30. How are complex compounds applicable in (a) electroplating of silver, gold or other noble metals (b) in photography.
31. Explain on the basis of Valence Bond Theory that diamagnetic $[\text{Ni}(\text{CN})_4]^{2-}$ has square planar structure and paramagnetic $[\text{NiCl}_4]^{2-}$ ion has tetrahedral geometry.
23. Explain as to how the two complexes of nickel $[\text{Ni}(\text{CN})_4]^{2-}$ and $\text{Ni}(\text{CO})_4$ have different structures but do not differ in their magnetic behaviours. (At. no. of Ni = 28).
34. Draw the structures of geometrical isomers of the coordination complexes— $[\text{Co}(\text{NH}_3)_3\text{Cl}_3]$ and $[\text{CoCl}_2(\text{en})_2]^+$
35. Write the IUPAC name of the complexes :
- (a) $[\text{NiCl}_2(\text{PPh}_3)_2]$ (b) $[\text{Co}(\text{NH}_3)_4\text{Cl}(\text{NO}_2)] \text{Cl}$
- (c) $\text{K}[\text{Cr}(\text{H}_2\text{O})_2(\text{C}_2\text{O}_4)_2]$

[Hint. : (a) Dichloridobis(triphenylphosphine)nickel (II);

36. Using IUPAC norms write the formulae for the following :
- (a) Tetrabromidocuprate (II)
- (b) Pentaamminenitrito-O- Cobalt (III)

*37. How does EDTA help as a cure for lead poisoning?

[Ans. : Calcium in Ca-EDTA complex is replaced by lead in the body. The more soluble complex lead-EDTA is eliminated in urine].

37. A complex is prepared by mixing CoCl_3 and NH_3 in the molar ratio of 1:4. 0.1 m solution of this complex was found to freeze at -0.372°C . What is the formula of the complex?

$$K_f \text{ of water} = 1.86^\circ\text{C/m}$$

$$\text{[Hint : } \Delta T_f = i K_f \times m = i \times 1.86 \times 0.1$$

$$\Delta T_f(\text{obs}) = 0.373^\circ\text{C}$$

This means each molecule of complex dissociates into two ions. Hence the formula is $i = 2$

- *38. The $[\text{Mn}(\text{H}_2\text{O})_6]^{2+}$ ion contains five unpaired electrons while $[\text{Mn}(\text{CN})_6]^{4-}$ ion contains only one unpaired electron. Explain using Crystal Field Theory:

SA (II) TYPE QUESTIONS (3 - MARK QUESTIONS)

39. Account for the following —
- $[\text{NiCl}_4]^{2-}$ is paramagnetic while $[\text{Ni}(\text{CO})_4]$ is diamagnetic though both are tetrahedral.
 - $[\text{Fe}(\text{H}_2\text{O})_6]^{3+}$ is strongly paramagnetic whereas $[\text{Ni}(\text{NH}_3)_6]^{2+}$ weakly paramagnetic.
 - $[\text{Co}(\text{NH}_3)_6]^{3+}$ is an inner orbital complex whereas $[\text{Ni}(\text{NH}_3)_6]^{2+}$ is in outer orbital complex.
40. Compare the following complexes with respect to their shape, magnetic behaviours and the hybrid orbitals involved.
- $[\text{CoF}_6]^{3-}$
 - $[\text{Cr}(\text{NH}_3)_6]^{3+}$
 - $[\text{Fe}(\text{CN})_6]^{4-}$
- [Atomic Number : Co = 27, Cr = 24, Fe = 26]
41. Draw the structure of
- cis-dichloridotetracyanochromate (II) ion
 - mer-triamminetrichloridocobalt (III)
 - fac-triaquatrininitro-N-cobalt (III)
42. Name the central metal atom/ion present in (a) Chlorophyll (b) Haemoglobin (c) Vitamin B-12. [Ans. : (a) Mg (b) Fe; (c) Co.]
43. A metal complex having composition $\text{Cr}(\text{NH}_3)_4 \text{Cl}_2 \text{Br}$ has been isolated in two forms 'A' and 'B'. The form 'A' reacts with AgNO_3 solution to give white precipitate which is readily soluble in dilute aqueous ammonia, whereas 'B' gives a pale yellow precipitate which is soluble in concentrated ammonia solution. Write the formula of 'A' and 'B'. Also mention the isomerism which arises among 'A' and 'B'.
- [Hint : A = $[\text{Cr}(\text{NH}_3)_4 \text{BrCl}] \text{Cl}$; B = $[\text{Cr}(\text{NH}_3)_4 \text{Cl}_2] \text{Br}$ are ionisation isomers].
44. Write the limitations of Valence Bond Theory.
45. Draw a sketch to show the splitting of d-orbitals in an octahedral crystal field state for a d^4 ion. How the actual electronic configuration of the split

d-orbitals in an octahedral crystal field is decided by the relative values of Δ_0 and pairing energy (P)?

- *46. For the complex $[\text{Fe}(\text{en})_2\text{Cl}_2]\text{Cl}$ identify
- the oxidation number of iron.
 - the hybrid orbitals and the shape of the complex.
 - the magnetic behaviour of the complex.
 - the number of geometrical isomers.
 - whether there is an optical isomer also?
 - name of the complex. [At. no. of Fe = 26]
48. A chloride of fourth group cation in qualitative analysis gives a green coloured complex [A] in aqueous solution which when treated with ethane-1, 2-diamine (en) gives pale yellow solution [B] which on subsequent addition of ethane-1, 2-diamine turns to blue/purple [C] and finally to violet [D]. Identify [A], [B], [C] and [D] complexes,

[Hint. : Nickel, [A] = $[\text{Ni}(\text{H}_2\text{O})_6]^{2+}$; [B] = $[\text{Ni}(\text{H}_2\text{O})_4(\text{en})]^{2+}$;

[C] = $[\text{Ni}(\text{H}_2\text{O})_2(\text{en})_2]^{2+}$; [D] = $[\text{Ni}(\text{en})_3]^{2+}$.

ORGANIC CHEMISTRY

SOME NOTEWORTHY POINTS

- If there are two or more functional groups, the order of decreasing priority is : $-\text{COOH} > -\text{SO}_3\text{H} > \text{anhydride} > \text{Ester} > \text{Acid halide} > \text{nitrile} > \text{aldehyde} > \text{ketone} > \text{alcohol} > \text{amine} \gg \text{C} = \text{C} < > - \text{C} \equiv \text{C} -$
- Anti Markownikov's addition takes place only with HBr in presence of a peroxide.
- Order of reactivity of hydrohalic acid : $\text{HI} > \text{HBr} > \text{HCl}$.
- Order of reactivity of alcohols with Lucas reagent : $3^\circ > 2^\circ > 1^\circ$.
- $\text{R} - \text{H} + \text{X}_2 \xrightarrow{h\nu} \text{R} - \text{X} + \text{HX}$. The order of reactivity of halogens $\text{Cl}_2 > \text{Br}_2 > \text{I}_2$. Order of reactivity of hydrogen atom abstracted is $3^\circ > 2^\circ > 1^\circ$.

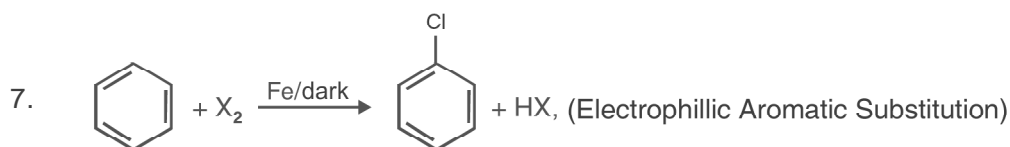
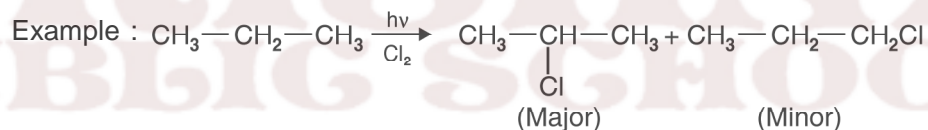

8. Order of reactivity in S_N1 and S_N2 mechanism are as follows :

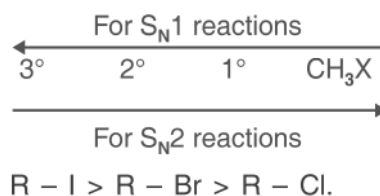

9. In case of optically active alkyl halide, S_N2 mechanism results in the inversion of configuration while S_N1 mechanism in racemisation.

10. Aryl halides are much less reactive towards nucleophilic substitution reactions. Presence of electron withdrawing groups (like $-\text{NO}_2$, $-\text{CN}$, $-\text{COOH}$ etc.) at *o*- and/or *p*-position to halogen increases the rate of reaction.
12. All the three types of monohydric alcohols (1° , 2° or 3°) except methanol can be prepared from Grignard Reagent

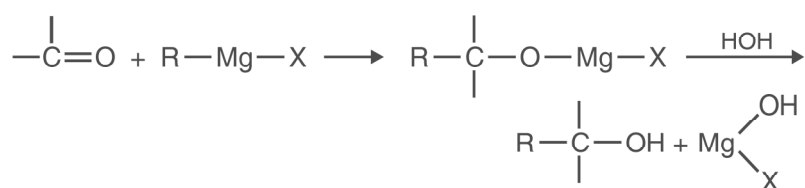

13. Alcohols

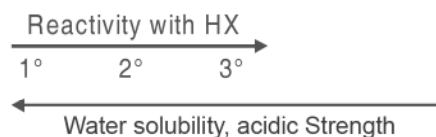

14. Presence of electron withdrawing group increases the acid strength of alcohol, phenol and carboxylic acid while presence of electron donating group decreases the acid strength.
E.W.G. : NO_2 , $-\text{X}$, $-\text{CN}$, $-\text{COOH}$, etc., E.D.G. : $-\text{R}$, $-\text{OR}$, $-\text{OH}$, $-\text{NH}_2$ etc.
15. In electrophilic aromatic substitution reaction, ring activating groups like $-\text{OH}$, $-\text{NH}_2$, $-\text{OR}$, are *o*- and *p*- directing whereas ring deactivating groups like $-\text{CHO}$, $> \text{C} = \text{O}$, $-\text{COOH}$, $-\text{NO}_2$, $-\text{SO}_3\text{H}$ are *m*-directing. Halogens (F, Cl, Br and I) are deactivating but are *o*- and *p*- directing groups.
16. 3° alcohols are resistant to oxidation due to lack of α -hydrogen.
17. Order of Acid strength : Alcohol < Phenol < Carboxylic acid, it is because of resonance stabilization of phenoxide and carboxylate ion. In carboxylate ion negative charge is delocalised over two oxygen atoms. while in phenoxide ion it is delocalised over one oxygen atom and the less electronegative C atom of benzene ring.
18. All organic compounds which form intermolecular H-bonds with water are soluble in water.
19. Intermolecular H-bonds of *p*- and *m*- nitrophenol increases water solubility/ Acid strength while intramolecular H-bonds in *o*-nitrophenol decreases

these properties.

20. In the reaction of alkyl aryl ether (Anisole) with HI, the products are always alkyl halide and phenol, because O–R bond is weaker than O–Ar bond.
22. In reaction of toluene with CrO_3 in presence of acetic anhydride is used to protect benzaldehyde as benzylidenediacetate to avoid further oxidation to benzoic acid.
23. Order of reactivity of aldehydes and ketones towards nucleophilic attack
 $\text{HCHO} > \text{CH}_3\text{CHO} > \text{CH}_3\text{CH}_2\text{CHO}$
 $\text{RCHO} > \text{R COR} ; \text{ArCHO} > \text{Ar COR} > \text{Ar CO Ar}$.

because of (i) +I Inductive effect of alkyl groups. (ii) steric hindrance of alkyl and aryl group reactivity of ketones is less than aldehydes.

24. Boiling and melting points of various organic compounds depend on intermolecular forces of attraction which depend on the following :
- (a) Inter molecular/intramolecular H-bonding.
 - (b) dipole-dipole interaction
 - (c) Molecular size
 - (d) Surface area. (branching decreases surface area of molecules).

25. Benzaldehyde does not reduce Fehling's reagent.
26. The more the K_a value, the lesser is the $\text{p}K_a$, a stronger acid always has higher K_a but a lower $\text{p}K_a$ value.
27. Order of Acid strength : $\text{HCOOH} > \text{C}_6\text{H}_5\text{COOH} > \text{C}_6\text{H}_5\text{CH}_2\text{COOH} > \text{CH}_3\text{COOH}, \text{CH}_3\text{CH}_2\text{COOH}$

28. $\begin{array}{c} \text{O} \\ \parallel \\ -\text{C}-\text{OH} \end{array}$ group in carboxylic acid is not a true carbonyl group because of resonance.



Hence, carboxylic acids do not give addition reaction of aldehydes and ketones.

(a) In aqueous solution order of basicity is :

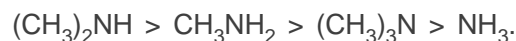
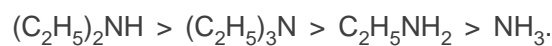

(b) In gaseous (vapour) state order of basicity is :



30. Basic character of aromatic amine

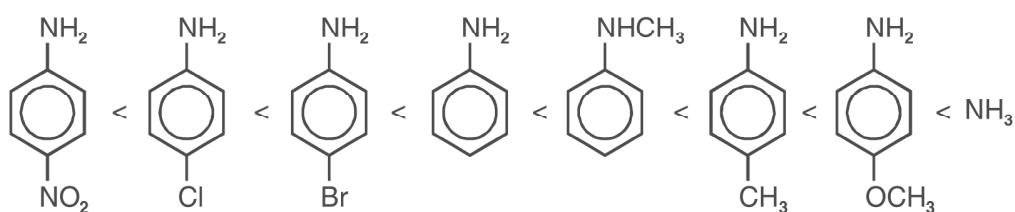

31. Hinsberg's reagent ($\text{C}_6\text{H}_5\text{SO}_2\text{Cl}$) is used to separate the mixtures of 1° , 2° and 3° amines.

32. Sulphanilic acid exists as zwitter ion, therefore it is amphoteric in nature.

33. Aryl diazonium salts are more stable than alkyl diazonium salts.

34. Aniline, phenol and benzoic acid do not show Friedel-Crafts Reaction.

35. The more the basic character, the more is the K_b value and lesser will be its $\text{p}K_b$ value.

35. In phenol and aniline, electron donating or electron withdrawing groups when present in ortho position, always have acid strengthening effect. This is called ortho effect.

USEFUL TIPS FOR IDENTIFICATION OF FUNCTIONAL GROUPS

For identification of chloro, bromo or Iodo alkanes, aq. KOH is added followed by AgNO_3 solution then precipitate of AgX is formed.

Iodoform Test is given by all organic compounds having

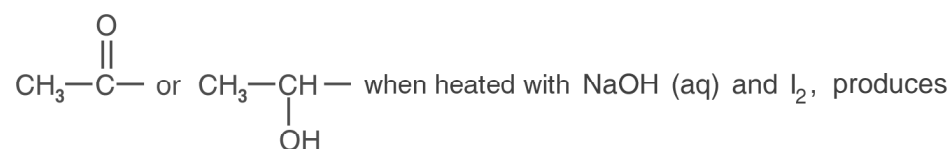

yellow iodoform (CHI_3)

Tollens' reagent test is given by organic compound having $\overset{\text{O}}{\parallel}{\text{C}}-\text{H}$ group

(formic acid $\text{H}-\overset{\text{O}}{\parallel}{\text{C}}-\text{O}-\text{H}$ also gives this test).

Tollens' reagent test is given by aldehydes

Methanoic acid and ethanoic acid gives deep red colour solution with iron (III) chloride solution.

Benzoic acid gives buff coloured precipitate with iron (III) chloride solution

Acid chlorides and esters may be recognised after hydrolysis. The resultant acid and alcohol may be tested for.

Amides are recognised by the liberation of ammonia on heating with alkali (NaOH or KOH) whereas ammonium salts liberate ammonia with alkali in the cold.

1° , 2° and 3° alcohols are distinguished by Lucas test.

1° , 2° and 3° amines can be distinguished with the help of Hinsberg reagent.

1° and 2° amines can be distinguished by Carbylamine test

Unit - 10

HALOALKANES AND HALOARENES

1. Write the IUPAC names of the following compounds.

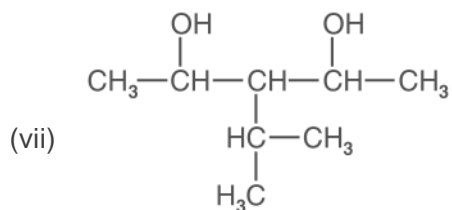
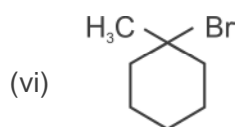
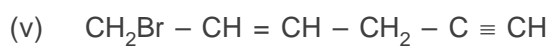
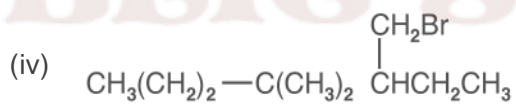
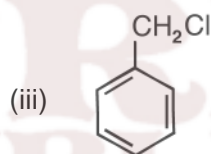
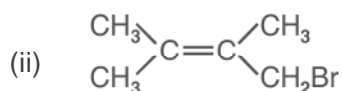
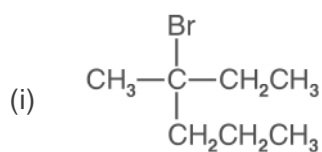

2. Write the structure of following halogen compounds
- 2-chloro-3-methylpentane
 - 2-(2-chlorophenyl)-1-iodooctane
 - 1-bromo-4-sec-butyl-2-methylbenzene.
 - p-bromotoluene.
 - chlorophenylmethane
3. Arrange the following in the increasing order of properly indicated :
- bromomethane, chloromethane, dichloromethane. (Increasing order of boiling points).
 - 1-chloropropane, isopropyl chloride, 1-chlorobutane (Increasing order of boiling point)
 - dichloromethane, chloroform, carbon tetrachloride. (Increasing order of dipole moment).
 - CH_3F , CH_3Cl , CH_3Br , CH_3I (Increasing reactivity towards nucleophilic substitution and increasing order of dipole moment)
 - o,m,p*-dichlorobenzenes (Increasing order of melting points).
4. Complete the following reactions :

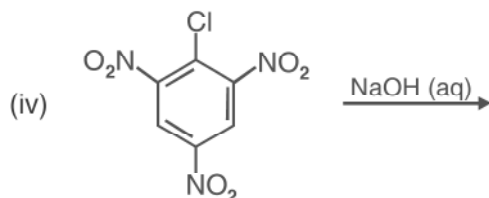
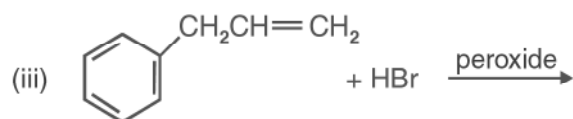
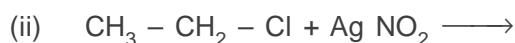
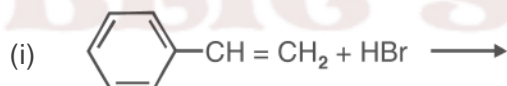

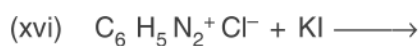
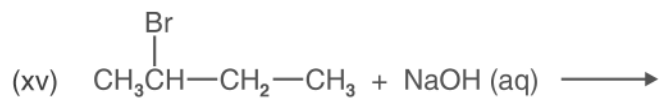
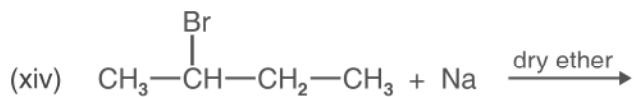
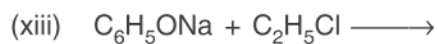
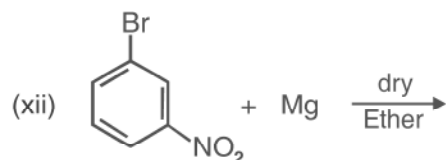
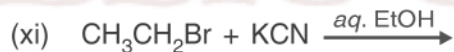
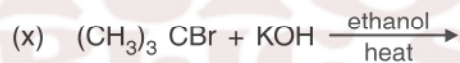
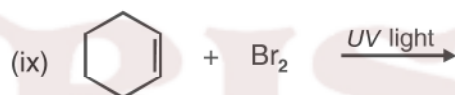
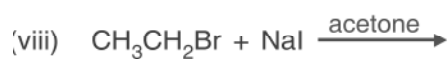
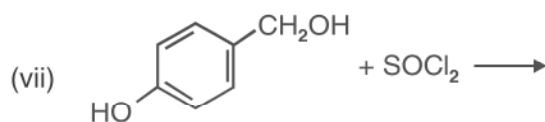
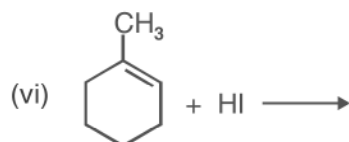
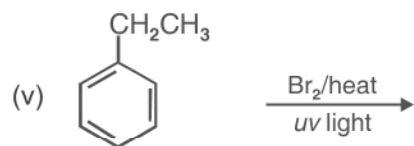

5. How will you bring about the following conversions?

- (i) benzene to 3-bromonitrobenzene
- (ii) ethanol to but-1-yne
- (iii) 1-bromopropane to 2-bromopropane
- (iv) benzene to 4-bromo-1-nitrobenzene
- (v) aniline to chlorobenzene
- (vi) 2-methyl-1-propene to 2-chloro-2-methylpropane
- (vii) ethyl chloride to propanoic acid
- (viii) but-1-ene to n-butyl iodide
- (ix) benzene to phenylchloromethane.
- (x) tert-butyl bromide to isobutyl bromide.

6. Identify the products formed in the following sequence :

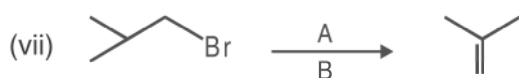
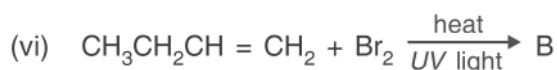
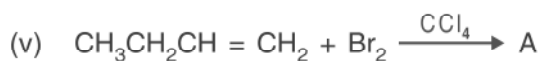
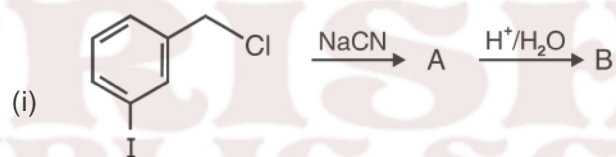



7. Explain the following reactions with suitable example :

- (i) Finkelstein reaction.
- (ii) Swarts reaction.
- (iii) Wurtz reaction.
- (iv) Wurtz-Fitting reaction
- (v) Friedel-Craft's alkylation reaction.
- (vi) Friedel-Craft's acylation reaction
- (vii) Sandmeyer reaction.

8. Write the major products and name the rule responsible for the formation of the product.

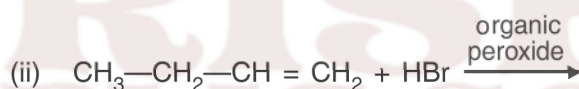
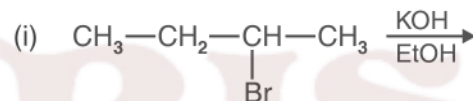

9. Write the difference between

- (i) enantiomers and diastereomers
- (ii) retention and inversion of configuration.
- (iii) electrophilic and nucleophilic substitution reactions.

10. Give a chemical test to distinguish between the following pairs of compounds:

- (i) chlorobenzene and cyclohexylchloride.
- (ii) vinyl chloride and ethyl chloride.
- (iii) n-propyl bromide and isopropyl bromide.

11. Give mechanism of the following reactions :

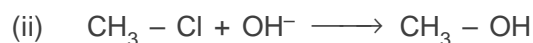
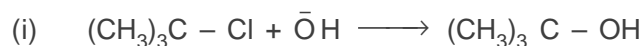

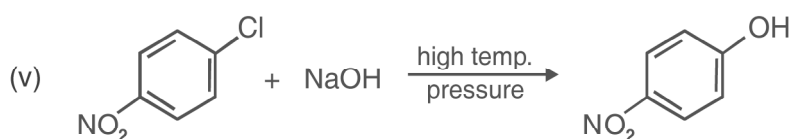
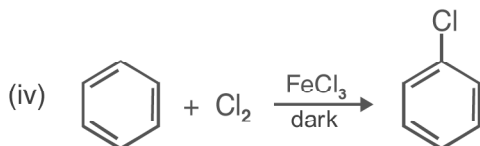
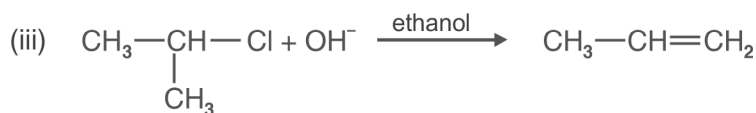

12. Which compound in each of the following pairs will react faster in S_N2 reaction with OH⁻ and why?

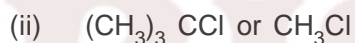
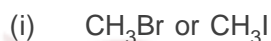

13. In the following pairs which halogen compound undergoes faster SN1 reaction?

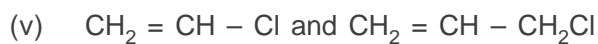
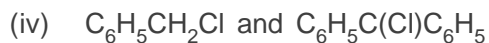

14. Give reasons for the following :

(i) The bond length of C-Cl bond is larger in haloalkanes than that in haloarenes.

(ii) Although alkyl halides are polar in nature but are not soluble in water.

- (iii) tert-butyl bromide has lower boiling point than n-Butyl bromide.
- (iv) haloalkanes react with KCN to form alkyl cyanide as main product while with AgCN alkyl isocyanide is the main product.
- (v) sulphuric acid is not used in the reaction of alcohol with KI.
- (vi) thionyl chloride is the preferred reagent for converting ethanol to chloroethane.
- (vii) haloalkanes undergo nucleophilic substitution reaction easily but haloarenes do not undergo nucleophilic substitution under ordinary conditions.
- (viii) chlorobenzene on reaction with fuming sulphuric acid gives ortho and para chlorosulphonic acids.
- (ix) 2, 4-dinitro chlorobenzene is much more reactive than chlorobenzene towards hydrolysis reaction with NaOH.
- (x) Grignard reagent should be prepared under anhydrous conditions.
- (xi) the dipole moment of chlorobenzene is lower than that of cyclohexyl chloride.
- (xii) neopentyl bromide undergoes nucleophilic substitution reactions very slowly
- (xiii) vinyl chloride is unreactive in nucleophilic substitution reaction.
- (xiv) An optically inactive product is obtained after the hydrolysis of optically active 2- bromobutane.

[Hint : The hydrolysis reaction occurs by S_N1 pathway. The carbocation is formed first which gives a mixture of (\pm) butan-2-ol in the second step].

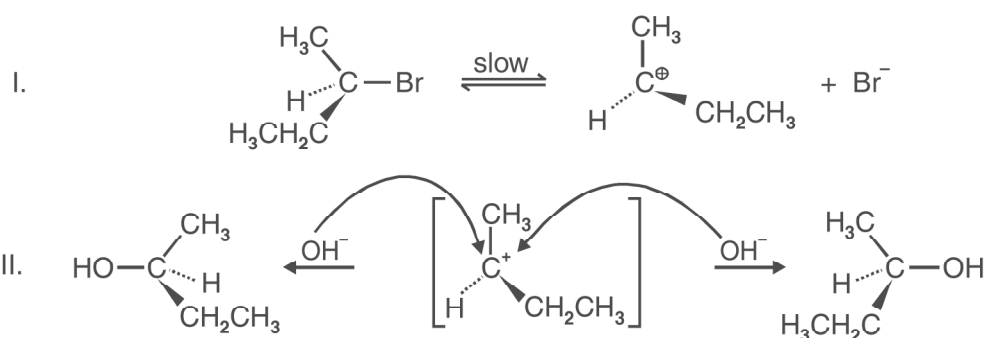

- (xv) methyl iodide is hydrolysed at faster rate than methyl chloride.

15. Write the different products and their number formed by the monochlorination of following compounds :

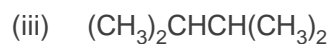
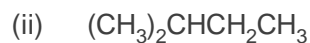
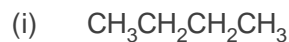

[Hint : (i) Two, (ii) four, (iii) three

16. (a) When 3-methylbutan-2-ol is treated with HBr, the following reaction takes places :

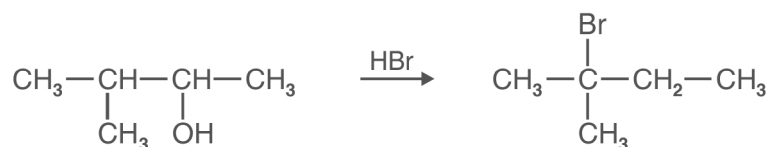

Give the mechanism for this reaction.

(b) In the following reaction :

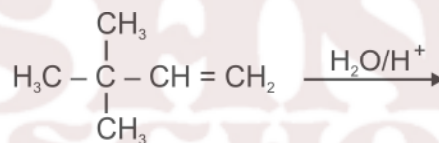

major and minor products are :

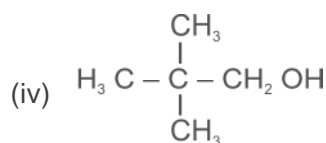
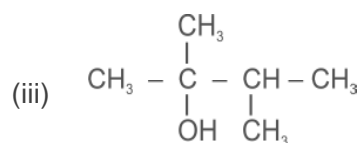
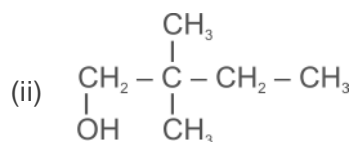
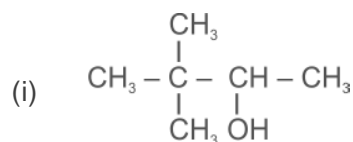

Ans. Major (iii) minor (i)

17. Give one use of each of following :

(i) Freon-12

(ii) DDT

(iii) Carbon tetrachloride

(iv) Iodoform

18. An optically active compound having molecular formula $C_7H_{15}Br$ reacts with aqueous KOH to give $C_7H_{15}OH$, which is optically inactive. Give mechanism for the reaction.

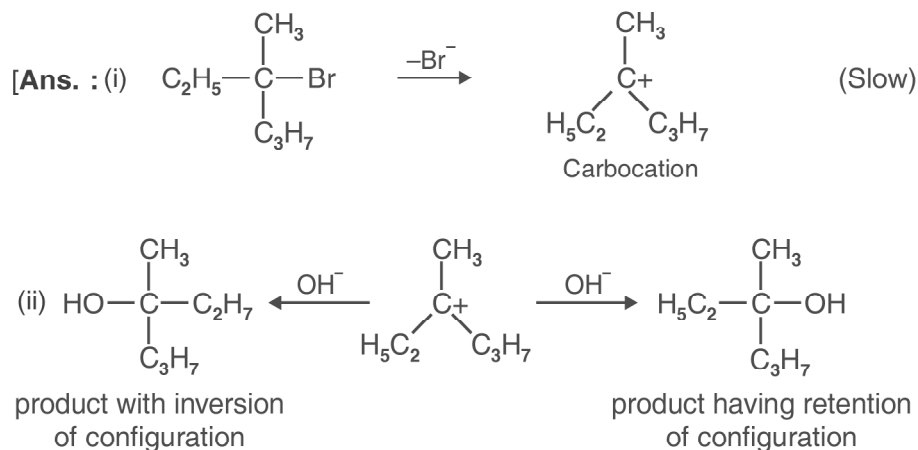

A racemic mixture is obtained which is optically inactive.]

19. An organic compound C_8H_9Br has three isomers A, B and C. A is optically active. Both A and B gave the white precipitate when warmed with alcoholic $AgNO_3$ solution in alkaline medium. Benzoic acid, terephthalic and p-bromobenzoic acid were obtained on oxidation of A, B and C respectively. Identify A, B and C.

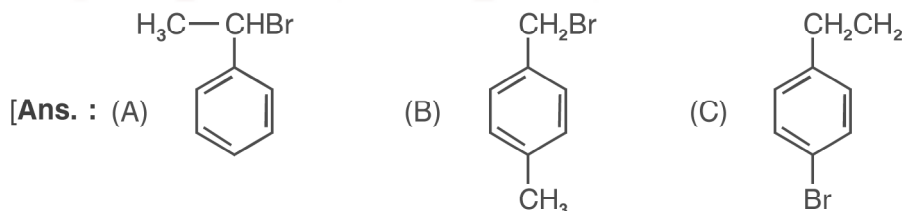

- *20. An alkyl halide X having molecular formula $C_6H_{13}Cl$ on treatment with potassium tert-butoxide gives two isomeric alkenes Y and Z but alkene y is symmetrical. Both alkenes on hydrogenation give 2, 3-dimethylbutane. Identify X, Y and Z.

[Ans.

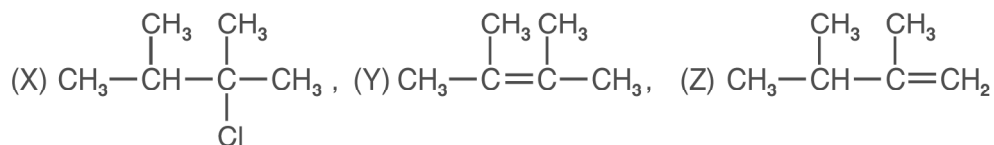

*21. An organic compound (A) having molecular formula C_3H_7Cl on reaction with alcoholic solution of KCN gives compound B. The compound B on hydrolysis with dilute HCl gives compound C. C on reduction with H_2/Ni gives 1-aminobutane. Identify A, B and C.

[Ans. : (A) $CH_3CH_2CH_2Cl$, (B) $CH_3CH_2CH_2CN$, (C) $CH_3CH_2CH_2CONH_2$

*22. Identify A, B, C, D, E, R and R' in the following sequence of reactions :

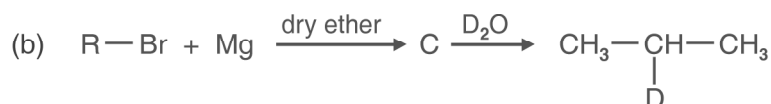
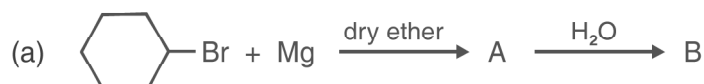

23. Which nomenclature is not according to IUPAC system.

(i) $Br-CH_2-CH=CH_2$; 1-bromoprop-2-ene

(ii) $CH_3-CH_2-\underset{\substack{| \\ Br}}{\overset{\substack{CH_3 \\ |}}{C}}-CH_2-\underset{\substack{| \\ Br}}{CH}-CH_3$, 4-bromo-2, 4-dimethylhexane

(iii) $CH_3-\underset{\substack{| \\ CH_3}}{CH}-\underset{\substack{| \\ \text{C}_6\text{H}_5}}{CH}-CH_2CH_3$, 2-methyl-3-phenylpentane

(iv) $CH_3-\underset{\substack{|| \\ O}}{C}-CH_2-CH_2-CH_2COON$, 5-oxohexanoic acid

Unit - 11

ALCOHOLS, PHENOLS AND ETHERS

1. Write IUPAC names of the following compounds :

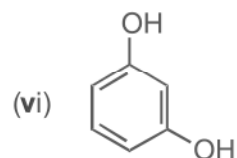
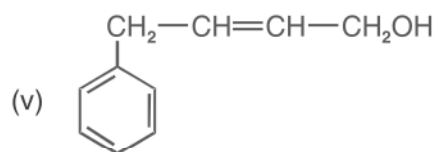
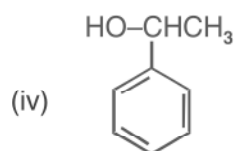
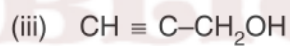
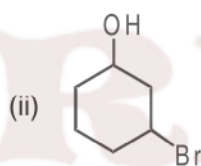
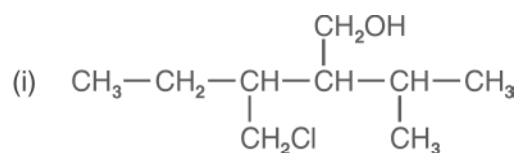

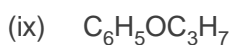
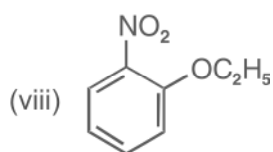
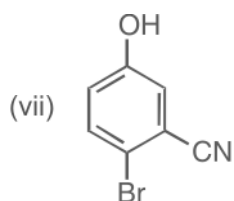

2. Write the structures of the compounds whose names are given below :

(i) 3, 5-dimethoxyhexane-1, 3, 5-triol

(ii) cyclohexylmethanol

(iii) 2-ethoxy-3-methylpentane

(iv) 3-chloromethylpentan-2-ol

(v) p-nitroanisole

3. Describe the following reactions with example :

(i) Hydroboration oxidation of alkenes

(ii) Acid catalysed dehydration of alcohols at 443K.

(iii) Williamson synthesis

(iv) Reimer-Tiemann reaction.

(v) Kolbe's reaction

(vi) Friedel-Crafts acylation of Anisole.

4. Complete the following reactions :

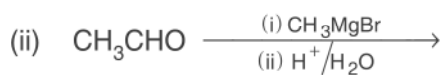
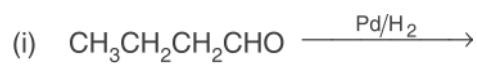

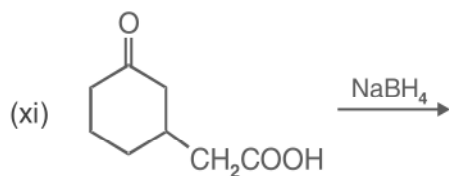
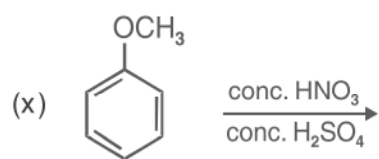
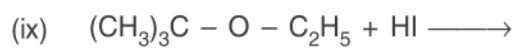
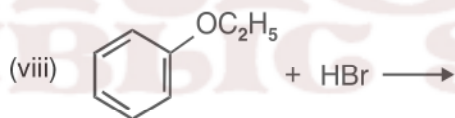
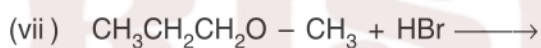
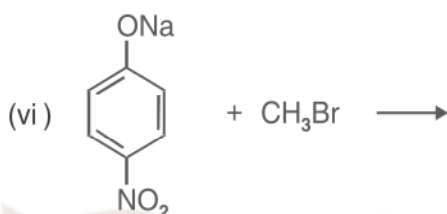
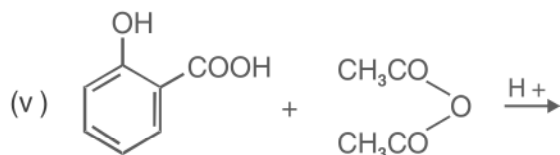
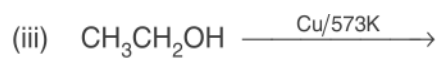

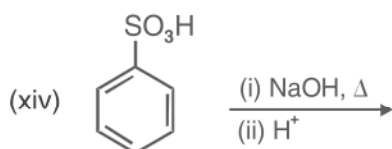
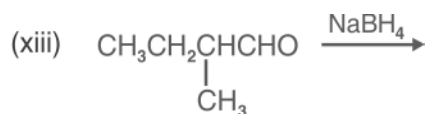

5. What happens when :
- aluminium reacts with tert-butyl alcohol
 - phenol is oxidised with chromic acid
 - cumene is oxidised in the presence of air and the product formed is treated with dilute acid.
 - phenol is treated with conc. HNO_3 .
 - phenol is treated with chloroform in presence of dilute NaOH .
6. How will you convert
- propene to propan-1-ol.
 - anisole to phenol
 - butan-2-one to butan-2-ol
 - ethanal to ethanol
 - phenol to ethoxybenzene
 - 1-phenylethene to 1-phenylethanol
 - formaldehyde to cyclohexylmethanol
 - butyl bromide to pentan-1-ol.
 - toluene to benzyl alcohol
 - 1-propoxypropane to propyl iodide
 - ethyl bromide to 1-ethoxyethane
 - methyl bromide to 2-methoxy-2-methylpropane
 - ethyl bromide to ethoxybenzene
 - ethanol to benzyl ethyl ether.

7. Identify the missing reactant or product A to D in the following equations:

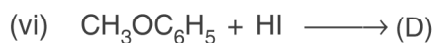
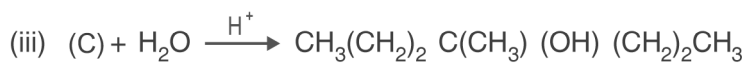
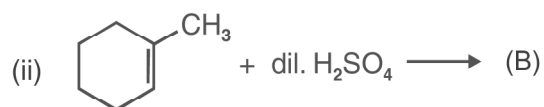
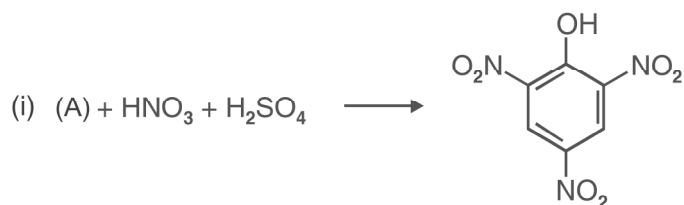

8. Identify X, Y and Z in the following sequence of reactions :

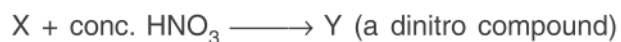
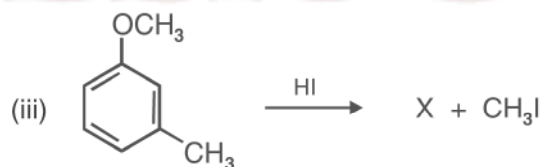
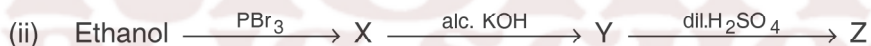

10. Write the mechanism for following reactions :

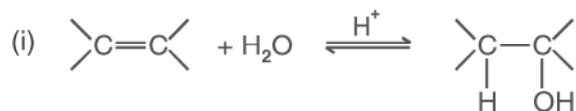

(acid catalysed hydration of alkenes)

- (ii) $\text{CH}_3 - \text{CH}_2 - \text{OH} \xrightarrow[443 \text{ K}]{\text{H}^+} \text{CH}_2 = \text{CH}_2$
(acid catalysed dehydration of alcohols)
- (iii) $2\text{CH}_3\text{CH}_2\text{OH} \xrightarrow[413 \text{ K}]{\text{H}^+} \text{CH}_3\text{CH}_2\text{OCH}_2\text{CH}_3$
(acid catalysed nucleophilic substitution reaction)
- (iv) $\text{CH}_3\text{OCH}_3 + \text{HI} \longrightarrow \text{CH}_3\text{OH} + \text{CH}_3\text{I}$
- (v) $(\text{CH}_3)_3\text{C} - \text{O} - \text{CH}_3 + \text{HI} \longrightarrow \text{CH}_3\text{OH} + (\text{CH}_3)_3\text{CI}$

11. Give reason for the following :

- (i) The C–O–C bond angle in dimethyl ether is (111.7°)
- (ii) Alcohols have higher boiling points than ethers of comparable molecular masses.
- (iii) Phenols are more acidic than alcohols.
- (iv) Nitrophenol is more acidic than o-methoxyphenol.
- (v) Phenol is more reactive towards electrophilic substitution reaction than benzene.
- (vii) The following is not an appropriate method for the preparation of t-butyl ethyl ether :

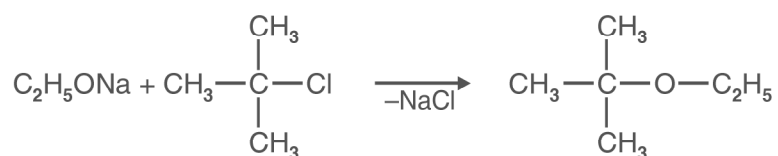

- (a) What would be the major product of this reaction?
- (b) Write suitable reaction for the preparation of t-butyl ethyl ether.
- (viii) The following is not an appropriate method for the preparation of 1-methoxy-4-nitrobenzene;

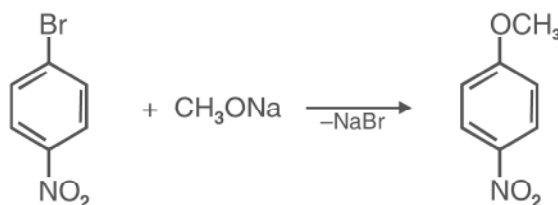

- (x) Write the suitable reaction for the preparation of 1-methoxy-4-nitrobenzene
- (ix) o-nitrophenol is steam volatile but p-nitrophenol is not.
- (x) phenol is less polar than ethanol.
- (xi) The phenyl methyl ether reacts with HI to form phenol and iodomethane and not iodobenzene and methanol.

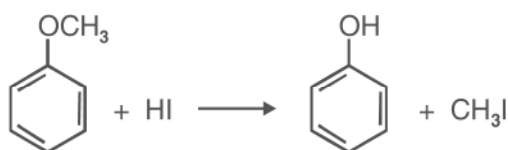

- (xii) methanol is less acidic than water.
 - (xiii) alcohols can act as weak base as well as weak acids.
 - (xiv) phenols do not give protonation reaction readily.
 - (xvi) absolute ethanol can not be obtained by fractional distillation of ethanol and water mixture.
12. Arrange the following in the increasing order of property shown :
- (i) methanol, ethanol, diethylether, ethyleneglycol. (Boiling points)
 - (ii) phenol, o-nitrophenol, m-nitrophenol, p-nitrophenol. (Acid strength)
 - (iii) dimethylether, ethanol, phenol. (Solubility in water)
 - (iv) n-butanol, 2-methylpropan-1-ol, 2-methylpropan-2-ol. (Acid strength)
13. Give a chemical test to distinguish between the following pair of compounds.
- (i) n-propyl alcohol and isopropylalcohol
 - (ii) methanol and ethanol
 - (iii) cyclohexanol and phenol.
 - (iv) propan-2-ol and 2-methylpropan-2-ol.
 - (v) phenol and anisole
 - (vi) ethanol and diethyl ether
- *14. Which of the following compounds gives fastest reaction with HBr and why?
- (i) $(\text{CH}_3)_3\text{COH}$
 - (ii) $\text{CH}_3\text{CH}_2\text{CH}_2\text{OH}$

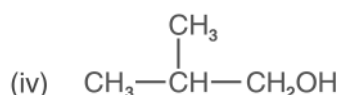
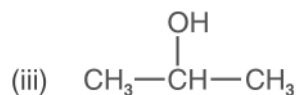

- *15. What is the function of ZnCl_2 (anhyd) in Lucas test for distinction between 1° , 2° and 3° alcohols.
16. An alcohol A ($\text{C}_4\text{H}_{10}\text{O}$) on oxidation with acidified potassium dichromate gives carboxylic acid B ($\text{C}_4\text{H}_8\text{O}_2$). Compound A when dehydrated with conc. H_2SO_4 at 443 K gives compound C. Treatment of C with aqueous H_2SO_4 gives compound D ($\text{C}_4\text{H}_{10}\text{O}$) which is an isomer of A. Compound D is resistant to oxidation but compound A can be easily oxidised. Identify A, B, C and D and write their structures.

[Ans. : [A] : $(\text{CH}_3)_2\text{CHCH}_2\text{OH}$ [B] : $\text{CH}_3\text{CH}(\text{CH}_3)\text{COOH}$
 [C] : $(\text{CH}_3)_2\text{C} = \text{CH}_2$ [D] : $(\text{CH}_3)_3\text{C} - \text{OH}$

- *17. An organic compound A having molecular formula $\text{C}_6\text{H}_6\text{O}$ gives a characteristic colour with aqueous FeCl_3 . When A is treated with NaOH and CO_2 at 400 K under pressure, compound B is obtained. Compound B on acidification gives compound C which reacts with acetyl chloride to form D which is a popular pain killer. Deduce the structure of A, B, C and D. What is the common name of Drug D?

[Ans. :

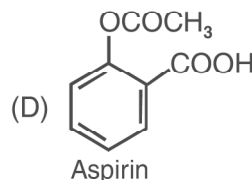
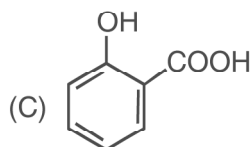
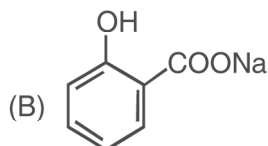
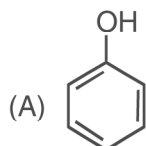

19. An ether A ($\text{C}_5\text{H}_{12}\text{O}$) when heated with excess of hot concentrated HI produced two alkyl halides which on hydrolysis form compounds B and C. Oxidation of B gives an acid D whereas oxidation of C gave a ketone E. Deduce the structures of A, B, C, D and E.

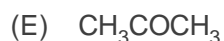
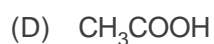
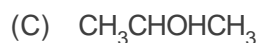
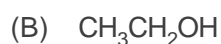
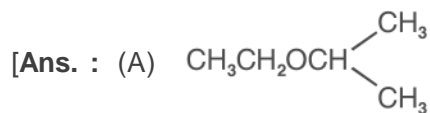

20. Phenol, $\text{C}_6\text{H}_5\text{OH}$ when it first reacts with concentrated sulphuric acid, forms Y. Y is reacted with concentrated nitric acid to form Z. Identify Y and Z and explain why phenol is not converted commercially to Z by reacting it with conc. HNO_3 .

[Ans. :

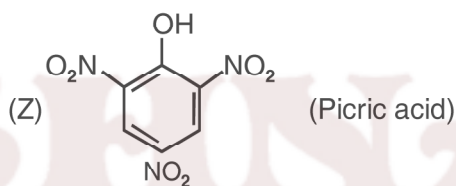
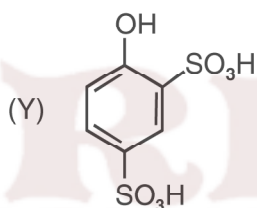

Phenol is not reacted directly with conc. HNO_3 because the yield of picric acid is very poor]

21. Synthesise the following alcohols from suitable alkenes.



22. How are the following ethers prepared by williumson synthesis?

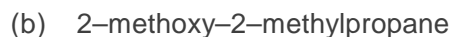

Unit - 12

ALDEHYDES, KETONES AND CARBOXYLIC ACIDS

1. Indicate the electrophilic and nucleophilic centres in acetaldehyde.
2. Write the IUPAC names of the following organic compounds :

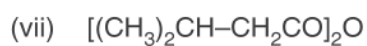
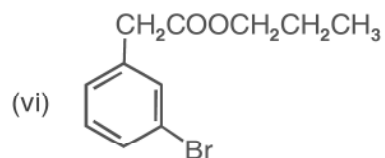
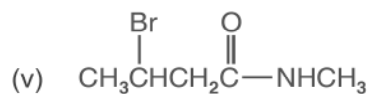
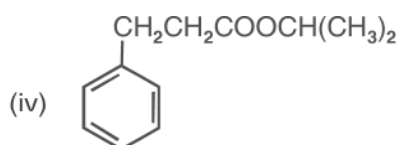
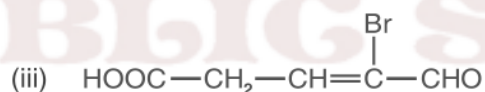
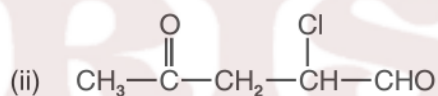
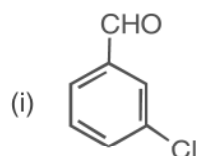

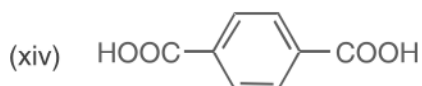
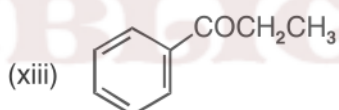
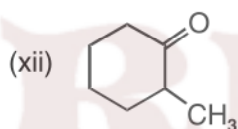
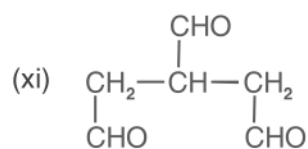
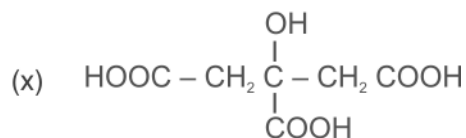
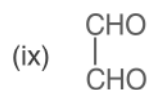
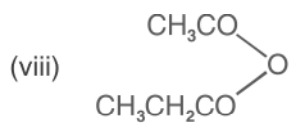

3. Explain the following reactions giving one example of each :
- Rosenmund reduction reaction
 - Stephen reaction
 - Etard reaction
 - Gatterman-Koch reaction
 - Aldol condensation
 - Cross aldol condensation
 - Cannizzaro reaction
 - Decarboxylation reaction

- (ix) Kolbe's reaction
- (x) Hell-Volhard-Zelinsky reaction
- (xi) Clemmensen reduction
- (xii) Wolff-Kishner reduction
- (xii) Haloform reaction.

4. How will you convert :

- (i) Isopropyl chloride to 2-methylpropionaldehyde.
- (ii) benzene to benzaldehyde
- (iii) benzoic acid to acetophenone
- (iv) propene to propanal
- (v) butanoic acid to 2-hydroxybutanoic acid
- (vi) benzoic acid to m-nitrobenzyl alcohol
- (vii) propanol to propene
- (viii) propanol to butan-2-one.
- (ix) methyl magnesium bromide to ethanoic acid
- (x) benzoic acid to benzyl chloride
- (xi) acetone to chloroform
- (xii) acetylene to acetic acid
- (xiii) formaldehyde to propanol
- (xiv) acetophenone to 2-phenylbutan-2-ol

5. Complete the following reactions :

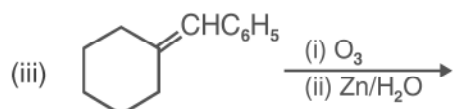
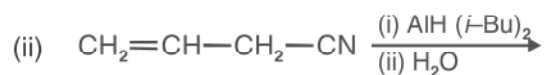
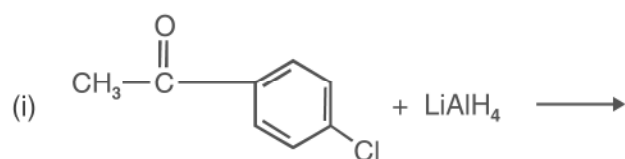

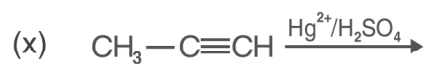
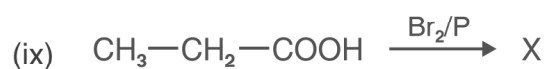
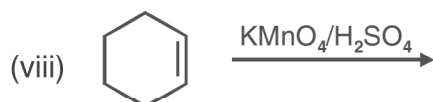
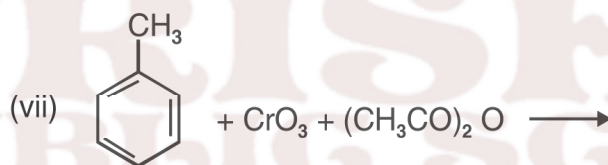
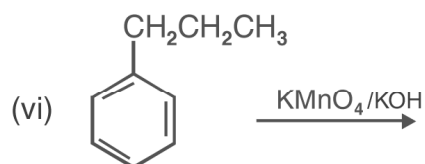
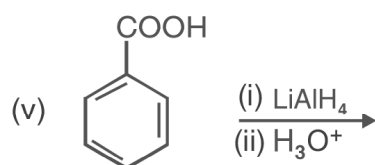
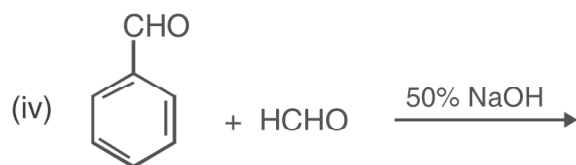

6. How will you prepare the following derivatives of acetone?

- (i) 2, 4-DNP derivative
- (ii) Schiff's base
- (iii) Oxime

7. Arrange the following in the increasing order of the property indicated

(i) CH_3CHO , HCHO , CH_3COCH_3 , $\text{C}_6\text{H}_5\text{CHO}$ (reactivity towards HCN)

(ii) propan-1-ol, propanone, propanal (boiling point)

8. Give the reaction mechanism for following reactions :

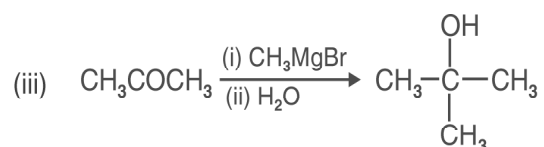
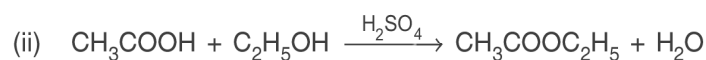

9. Give one chemical test to distinguish between following pair of compounds:
Write the chemical reaction involved.

(i) propan-2-ol and propanone

(ii) ethyl acetate and methyl acetate

(iii) benzaldehyde and benzoic acid

(iv) benzaldehyde and acetaldehyde

(v) formic acid and acetic acid

(vi) propanal and propan-1-ol

(vii) ethanoic acid and ethylethanoate

(viii) CH_3CHO and CH_3COCH_3

(ix) CH_3CHO and HCHO

(x) acetophenone and benzophenone

10. Give reason for the following (i) cyclohexanone form cyanohydrin in good yield but 2, 2, 6 – trimethylcyclohexanone does not.

(ii) Benzaldehyde does not give Fehling's test.

(iii) The alpha H atoms in ethanal are acidic in nature.

(iv) p-nitrobenzaldehyde is more reactive than benzaldehyde towards nucleophilic addition reactions.

- (v) Acetic acid does not give sodium bisulphite addition product.
 - (vi) For the formation of ethyl acetate from acetic acid and ethanol in presence of sulphuric acid, the reaction mixture is heated to remove water as fast as it is formed.
 - (vii) Chloroacetic acid has lower pka value than acetic acid.
 - (viii) Monochloroethanoic acid is a weaker acid than dichloroethanoic acid.
 - (ix) Benzoic acid is stronger acid than ethanoic acid.
 - (x) Aldehydes are more reactive towards nucleophilic reagents than ketones .
 - (xi) Benzaldehyde does not undergo aldol condensation.
 - (xii) Formic acid reduces Tollens' reagent.
 - (xiii) Electrophilic substitution in benzoic acid takes place at m-position.
 - (xiv) Carboxylic acids do not give characteristic reactions of carbonyl group.
 - (xv) Formaldehyde gives Cannizzaro reaction whereas acetaldehyde does not.
 - (xvi) tert-butyl benzene cannot be oxidised with KMnO_4 .
 - (xviii) There are two $-\text{NH}_2$ groups in semicarbazide. However, only one $-\text{NH}_2$ group is involved in the formation of semicarbazones.
 - (xix) Benzoic acid is less soluble in water than acetic acid.
 - (xx) Formic acid is a stronger acid than acetic acid.
- *11. You are given four different reagents Zn-Hg/HCl , $\text{NH}_2\text{NH}_2/\text{OH}^-$ in Glycol, H_2/Ni and NaBH_4 . Select one reagent for the following transformation and give reasons to justify your answer.

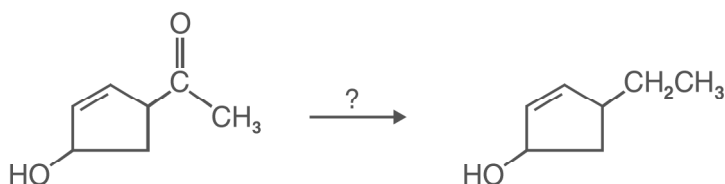

[Hint : OH group and alkene are sensitive groups to HCl so clemmeson reduction cannot be used. Hence $\text{NH}_2\text{NH}_2/\text{OH}^-$ in glycol will be used.

- *12. An organic compound (A) having molecular formula $C_5H_{10}O$ gives a positive 2, 4-DNP test. It does not reduce Tollens' reagent but forms an addition compound with sodium hydrogen sulphite. On reaction with I_2 in alkaline medium, it forms a yellow precipitate of compound B and another compound C having molecular formula $C_4H_7O_2Na$. On oxidation with $KMnO_4$, [A] forms two acids D and E having molecular formula $C_3H_6O_2$ and $C_2H_4O_2$ respectively. Identify A, B, C, D and E.

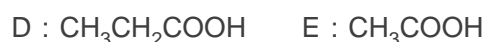
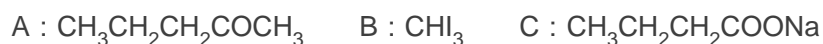

- *13. Formaldehyde and acetaldehyde on treatment with dil. NaOH form A which on heating changes to B. When B is treated with HCN, it forms C. Reduction of C with DIBAL-H yields D which on hydrolysis gives E. Identify A, B, C, D and E.

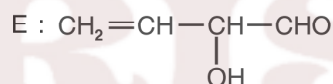
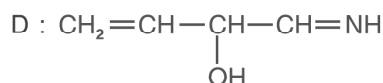
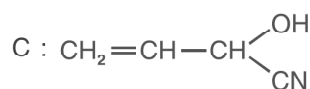

- *14. Identify the missing reagent/products in the following reactions :

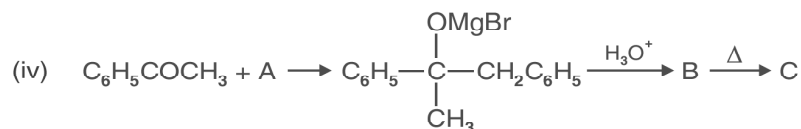
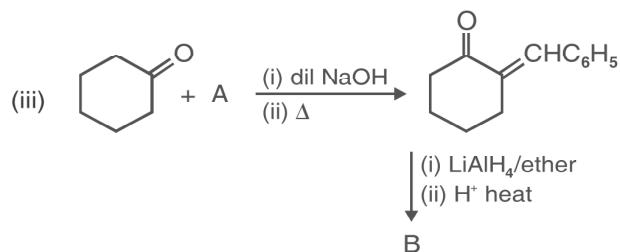
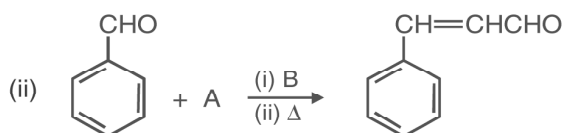
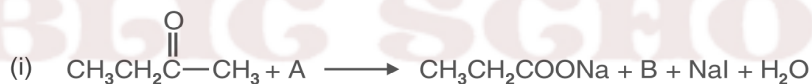

15. Identify A, B, C, D and E in the following sequences of reactions :

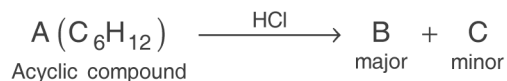

*16. A tertiary alcohol 'A' on acid catalyzed dehydration gave product 'B'. Ozonolysis of 'B' gives compounds 'C' and 'D'. Compound 'C' on reaction with KOH gives benzyl alcohol and compound 'E'. Compound 'D' on reaction with KOH gives α,β - unsaturated ketone having the following structure.

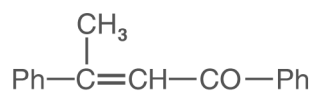

Identify A, B, C, D and E

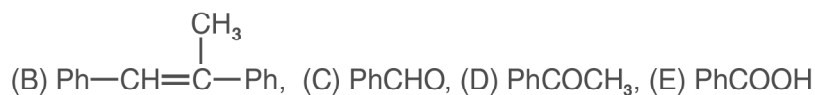
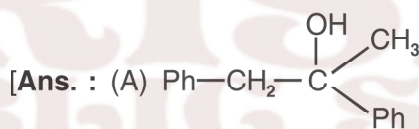

*17. Identify A, B, C, D and E in the following sequence of reactions :

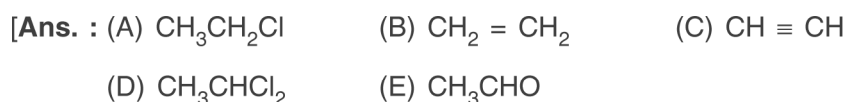
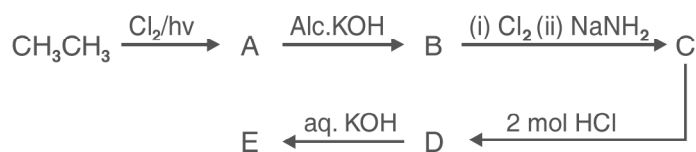

*18. Arrange the following acids in the order of increasing acid strength

(i) formic acid, benzoic acid, acetic acid

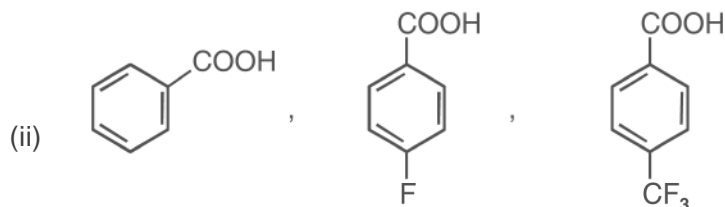

(iii) $\text{CH}_3\text{CH}_2\text{COOH}$, $\text{C}_6\text{H}_5\text{COOH}$, CH_3COOH , $\text{C}_6\text{H}_5\text{CH}_2\text{COOH}$

*19. During the reaction of a carbonyl compound with a weak nucleophile, H^+ ions are added as catalyst. Why?

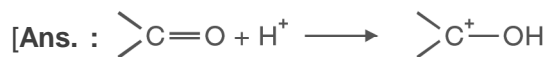

H^+ ions get attached to oxygen atom and make carbonyl carbon more electrophilic in nature.]

*20. During reaction of carbonyl compound with 2, 4-DNP reagent, the pH of the reaction mixture has to be maintained between 3 and 4. Why?

[Ans. : H^+ ions increase the electrophilicity of carbonyl carbon. When H^+ ions are in excess, they protonate the NH_2 group of 2, 4-DNP. After protonation $-\text{N}^+\text{H}_3$ group does not act as nucleophile.]

*21. An aromatic compound X with molecular formula C_9H_{10} gives the following chemical tests :

- Forms 2, 4-DNP derivative
- Reduces Tollens' reagent
- Undergoes Cannizzaro reaction
- On vigorous oxidation gives 1, 2-benzenedicarboxylic acid.

Identify X and write its IUPAC name. Also write the reactions involved in the formation of above mentioned products.

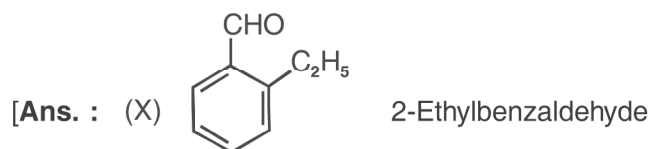

22. Iodoform can be prepared from, all except.

- | | |
|---------------------------|------------------------|
| (i) Ethyl methyl ketone | (ii) Isopropyl alcohol |
| (iii) 3-methylbutan-2-one | (iv) Isobutyl alcohol |
- Ans : (iv)

Unit - 13

AMINES

1. Write IUPAC names of the following :

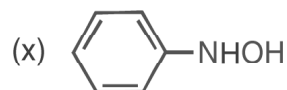
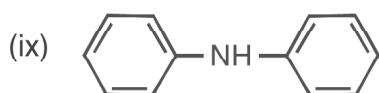
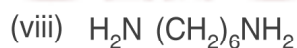
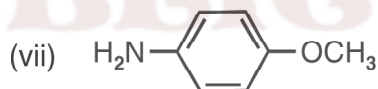
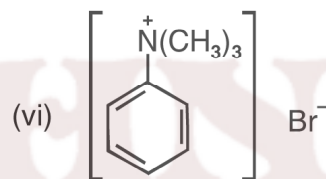
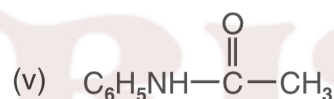
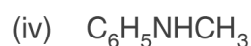
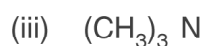
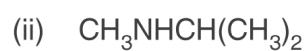
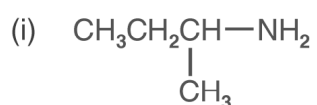

2. Giving an example of each, describe the following reactions :

- (i) Hoffman bromamide reaction
- (ii) Gabriel phthalimide synthesis
- (iii) Gatterman reaction
- (iv) Coupling reaction
- (vi) Carbylamine reaction
- (vii) Acetylation of aniline.

3. Describe the Hinsberg's test for identification of primary, secondary and tertiary amines. Also write the chemical equations of the reactions involved.
4. Arrange the following in the increasing order of given property indicated.

(i) $C_2H_5NH_2$, $(C_2H_5)_2NH$, $(C_2H_5)_3N$ and NH_3 , (Basic strength in aqueous solution).

(ii) $C_2H_5NH_2$, $(C_2H_5)_2NH$, $(C_2H_5)_3N$ and CH_3NH_2 . (Basic strength in gaseous phase).

(iii) Aniline, p-toluidine, p-nitroaniline. (Basic strength).

(iv) C_2H_5OH , $(CH_3)_2NH$, $C_2H_5NH_2$ (Boiling point)

5. Identify A and B in the following reactions :

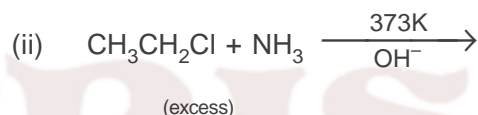
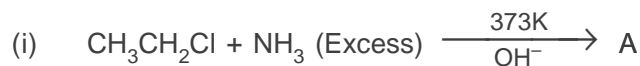

6. How will you bring about the following conversions?

(i) benzene to Aniline

(ii) aniline to benzene

(iii) ethanoic acid to ethanamine

(iv) p-toluidine to 2-bromo-4-methylaniline.

(v) methylbromide to ethanamine

(vi) benzenediazonium chloride to nitrobenzene

(vii) ethylamine to methylamine

(ix) benzene to sulphanilic acid

(x) hexanenitrile to 1-aminopentane.

7. Write the products formed in the following sequence of reactions :-

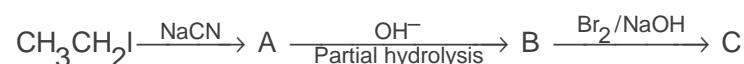

8. Identify the missing reagent/product in the following reactions :

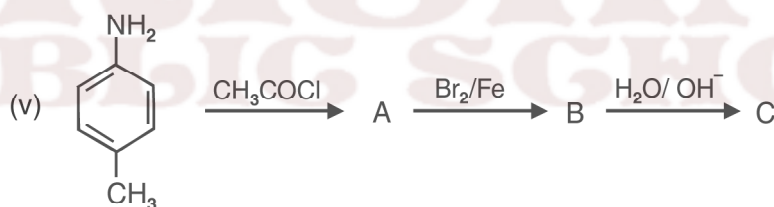
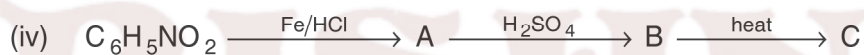
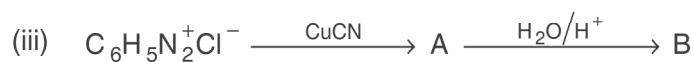
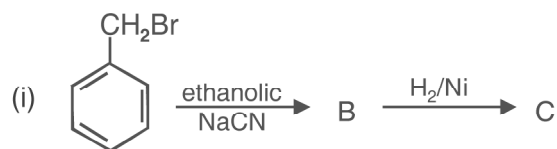

9. Give one chemical test to distinguish between the following pairs of compounds :

- (i) methylamine and dimethylamine
- (ii) secondary and tertiary amines
- (iii) ethylamine and aniline
- (iv) aniline and benzylamine
- (v) methylamine and methanol
- (vi) methylamine and N, N-dimethylamine
- (vii) ethanol and ethanamine

10. Explain why :
- (i) The C–N–C bond angle in trimethyl amine is 108°
 - (ii) the quaternary ammonium salts having four different alkyl groups are optically active
 - (iii) alkylamines are more basic than ammonia
 - (iv) aniline cannot be prepared by Gabriel phthalimide synthesis
 - (v) Gabriel phthalimide synthesis is preferably used for synthesising primary amines.
 - (vi) ethylamine is soluble in water but aniline is not
 - (vii) amines are soluble in dilute HCl.
 - (viii) amines have lower boiling point than alcohols of comparable molecular masses.
 - (ix) 1° amines have higher boiling points than 2° amines which in turn, are higher boiling than 3° amines.
 - (x) The pK_b value of benzeneamine is 9.33 while that of ammonia is 4.75.
 - (xi) aniline does not undergo Friedel-Crafts reaction.
 - (xii) aniline readily forms 2, 4, 6-tribromoaniline on reaction with bromine water.
 - (xiii) sulphanilic acid is soluble in water.
 - (xiv) methylamine in water reacts with ferric chloride to precipitate hydrated ferric oxide.
 - (xv) diazonium salt of aromatic amines are more stable than the diazonium salts of aliphatic amines.
 - (xvi) Although amino group is o, p-directing in aromatic electrophilic substitution reactions, aniline on nitration gives a substantial amount of m-nitroaniline.
11. Why do amines act as nucleophiles? Give example of a reaction in which methylamine acts as a nucleophile.
- *12. Three isomeric amines A, B and C have the molecular formula C_3H_9N . Compound A on reaction with benzene sulphonyl chloride forms a product which is soluble in NaOH. Compound B on reaction with benzene sulphonyl chloride forms a product which is insoluble in NaOH and compound C

does not react with benzene sulphonyl chloride. Identify A, B and C.

[Ans. : (A) $\text{CH}_3\text{CH}_2\text{CH}_2\text{NH}_2$ (B) $\text{CH}_3\text{CH}_2\text{NHCH}_3$ (C) $(\text{CH}_3)_3\text{N}$]

13. An organic compound A ($\text{C}_2\text{H}_3\text{N}$) is used as a solvent of choice for many organic reactions because it is not reactive in mild acidic and basic conditions. Compound A on treatment with Ni/H_2 forms B. When B is treated with nitrous acid at 273K, ethanol is obtained. When B is warmed with chloroform and NaOH, a foul smelling compound C formed. Identify A, B and C.

[Ans. : (A) CH_3CN (B) $\text{CH}_3\text{CH}_2\text{NH}_2$ (C) $\text{CH}_3\text{CH}_2\text{NC}$]

14. An organic compound [A] $\text{C}_3\text{H}_6\text{O}_2$ on reaction with ammonia followed by heating yield B. Compound B on reaction with Br_2 and alc. NaOH gives compound C ($\text{C}_2\text{H}_7\text{N}$). Compound C forms a foul smelling compound D on reaction with chloroform and NaOH. Identify A, B, C, D and the write the equations of reactions involved.

[Hint : (A) $\text{CH}_3\text{CH}_2\text{COOH}$ (B) $\text{CH}_2\text{CH}_2\text{CONH}_2$
(C) $\text{CH}_3\text{CH}_2\text{NH}_2$ (D) $\text{CH}_3\text{CH}_2\text{NC}$.]

KRISHNA
PUBLIC SCHOOL

Unit - 14

BIOMOLECULES

POINTS TO REMEMBER

1. Carbohydrates are optically active polyhydroxy aldehydes or ketones or molecules which provide such units on hydrolysis.
2. Carbohydrates are classified into three groups (i) monosaccharides, (ii) oligosaccharides and (iii) polysaccharides.
3. Glucose, the most important source of energy for mammals, is obtained by the digestion of starch.
4. Monosaccharides are held together by glycosidic linkages to form disaccharides or polysaccharides.
5. Proteins are the polymers of about twenty different amino acids which are linked by peptide bonds. Ten amino acids are called essential amino acids because they can not be synthesised in our body, hence must be provided through diet.
6. Proteins perform various structural and dynamic functions in the organisms. Proteins which contain only amino acids, are called simple proteins.
7. The secondary or tertiary structure of proteins get disturbed on change of pH or temperature and they are not able to perform their functions. This is called denaturation of proteins.
8. Enzymes are biocatalysts which speed up the reactions in biosystems. They are very specific and selective and efficient in their actions and chemically all enzymes are proteins.
9. Vitamins are necessary food factors required in the diet. They are classified as fat soluble (A, D, E and K) and water soluble (B group and C).
10. Nucleic acids are responsible for the transfer of characters from parents to offsprings.
11. There are two types of nucleic acids DNA and RNA. DNA contains a five carbon sugar molecule called 2-deoxyribose and RNA contains ribose.
12. Both DNA and RNA contain adenine, guanine and cytosine. The fourth base is thymine in DNA and uracil in RNA. The structure of DNA is double

stranded while that of RNA is a single stranded molecule.

13. DNA is the chemical basis of heredity and has the coded message for proteins to be synthesised.
14. There are three types of RNA, *i.e.*, m-RNA, r-RNA and t-RNA which actually carry out the protein synthesis in the nucleus.
15. Human stomach does not have any enzyme capable of breaking cellulose molecules and thus we cannot digest cellulose.

QUESTIONS

VSA TYPE QUESTIONS (1 - MARK QUESTIONS)

1. Name polysaccharide which is stored in the liver of animals.
2. What structural feature is required for a carbohydrate to behave as reducing sugar?

[Hint : The carbonyl group of any one monosaccharide present in carbohydrate should be free]

3. How many asymmetric carbon atoms are present in D (+) glucose?
4. Name the enantiomer of D-glucose.

[Hint : L-glucose]

5. Give the significance of (+)-sign in the name D-(+)-glucose.

[Hint : (+) sign indicates dextrorotatory nature of glucose].

6. Give the significance of prefix 'D' in the name D-(+)-glucose.

[Hint : 'D' Signifies that –OH group on C-5 is on the right hand side]

7. Glucose is an aldose sugar but it does not react with sodium hydrogen sulphite. Give reason.

[Hint : The –CHO group reacts with –OH group at C–5 to form a cyclic hemiacetal].

8. Why is sucrose called invert sugar?

[Hint : When sucrose is hydrolysed by water, the optical rotation of solution changes from positive to negative.]

9. Name the building blocks of proteins.
10. Give the structure of simplest optically active amino acid.
11. Name the amino acid which is not optically active.
12. Write the Zwitter ionic form of aminoacetic acid.

13. Name the enzyme which catalyses the hydrolysis of maltose into glucose.
14. Give reason : Amylase present in the saliva becomes inactive in the stomach.
[Hint : HCl present in stomach decreases the pH]
15. How would you explain the amphoteric behavior of amino acids.
[Hint : Amino acids are amphoteric due to the presence of both acidic and basic functional groups.]
16. Which forces are responsible for the stability of α – helical structure of proteins.
17. How are polypeptides different from proteins.
18. Which nucleic acid is responsible for carrying out protein synthesis in the cell.
19. The two strands in DNA are not identical but complementary. Explain.
[Hint : H-bonding is present between specific pairs of bases present in stands.]
20. When RNA is hydrolysed, there is no relationship among the quantities of different bases obtained. What does this fact suggest about the structure of RNA.
[Hint : RNA is single stranded].
21. What type of linkage holds together the monomers of DNA and RNA.
[Hint : Phosphodiester linkage]
22. Mention the number of hydrogen bonds between adenine and thymine.
23. A child diagnosed with bone deformities, is likely to have the deficiency of which vitamin?
24. What is meant by the term DNA fingerprinting?
25. List two important functions of proteins in human body.
26. Name the vitamin responsible for coagulation of blood.
27. Except vitamin B₁₂, all other vitamins of group B, should be supplied regularly in diet. Why?
28. How is glucose prepared commercially?
29. What is the structural difference between glucose and fructose?
30. What is the difference between an oligosaccharide and a polysaccharide.
31. Give the Haworth projection of D-glucopyranose.

SA (I) TYPE QUESTIONS (2 - MARK QUESTIONS)

1. What are anomers. Give the structures of two anomers of glucose.
2. Write the hydrolysed products of
 - (i) maltose
 - (ii) cellulose.
3. Name the two components of starch? Which one is water soluble?
4. (i) Acetylation of glucose with acetic anhydride gives glucose pentaacetate. Write the structure of the pentaacetate.
(ii) Explain why glucose pentaacetate does not react with hydroxylamine?
[Hint : The molecule of glucose pentaacetate has a cyclic structure in which –CHO is involved in ring formation with OH group at C–5]
5. What are vitamins? How are they classified?
6. (i) Why is sucrose called a reducing sugar?
(ii) Give the type of glycosidic linkage present in sucrose.
7. Classify the following as monosaccharides or oligosaccharides.
 - (i) Ribose
 - (ii) Maltose
 - (iii) Galactose
 - (iv) Lactose
8. Write the products of oxidation of glucose with
 - (a) Bromine water
 - (b) Nitric acid
9. State two main differences between globular and fibrous proteins.
10. Classify the following α -amino acids as neutral, acidic or basic.
 - (i) $\text{HOOC} - \text{CH}_2 - \text{CH}(\text{NH}_2) \text{COOH}$
 - (ii) $\text{C}_6\text{H}_5 - \text{CH}_2 - \text{CH}(\text{NH}_2) \text{COOH}$
 - (iii) $\text{H}_2\text{N} - (\text{CH}_2)_4 - \text{CH}(\text{NH}_2) - \text{COOH}$
 - (iv) $\text{HN} = \underset{\text{NH}_2}{\text{C}} - (\text{CH}_2)_3 - \text{CH}(\text{NH}_2)\text{COOH}$
11. You have two amino acids, *i.e.* glycine and alanine. What are the structures of two possible dipeptides that they can form?
12. What are essential and non essential amino acids? Give one example of each type.
13. Name four type of intermolecular forces which stabilize 2° and 3° structure of proteins.

[Hint : Hydrogen bonds, disulphide linkages, vander Waals and electrostatic forces of attraction.]

14. Classify the following as globular or fibrous proteins.
(i) Keratin (ii) Myosin
(iii) Insulin (iv) Haemoglobin.
15. What do you understand by
(a) denaturation of protein (b) specificity of an enzyme.
16. On electrolysis in acidic solution amino acids migrate towards cathode while in alkaline solution they migrate towards anode.
[Hint : In acidic solution, COO^- group of zwitter ion formed from α -amino acid is protonated and NH_3^+ groups is left unchanged while in basic solution deprotonation converts NH_3^+ to NH_2 and COO^- is left unchanged.]
17. (i) Name the disease caused by deficiency of vitamin D.
(ii) Why cannot vitamin C be stored in our body?
18. Define the terms hypervitaminosis and avitaminosis.
[Hint : Excess intake of vitamin A and D causes hypervitaminosis while multiple deficiencies caused by lack of more than one vitamins are called avitaminosis]
19. Explain what is meant by :
(i) a peptide linkage (ii) a glycosidic linkage?
[Hint : (i) Peptide linkage refers to the $-\text{CONH}-$ linkage formed by reaction between $-\text{COOH}$ group of one amino acid with $-\text{NH}_2$ group of the other amino acid.
(ii) Glycosidic linkage refers to $-\text{C}-\text{O}-\text{C}-$ linkage between two sugars formed by loss of H_2O .]
20. Give the sources of vitamin A and E and name the deficiency diseases resulting from lack of vitamin A and E in the diet.
21. What are the main functions of DNA and RNA in human body.

SA(II) TYPE QUESTIONS (3 - MARK QUESTIONS)

1. How are carbohydrate classified?
2. (i) Name four bases present in DNA.
(ii) Which of them is not present in RNA.
(iii) Give the structure of a nucleotide of DNA.
3. Differentiate between the following :
(i) secondary and tertiary structure of protein.
(ii) α -Helix and β -pleated sheet structure of protein.
(iii) fibrous and globular proteins.

Unit - 15

POLYMERS

Points to Remember

1. Polymers are defined as high molecular mass macromolecules which consist of repeating structural units derived from the appropriate monomers.
2. In presence of an organic peroxide initiator, the alkenes and their derivatives undergo addition polymerisation or chain growth polymerisation through a free radical mechanism. Polythene, teflon, orlon etc. are formed by addition polymerisation of an appropriate alkene or its derivative.
3. Condensation polymerisation reactions are shown by the addition of bi- or poly functional monomers containing $-NH_2$, $-OH$ and $-COOH$ groups. This type of polymerisation proceeds through the elimination of certain simple molecules such as H_2O , NH_3 etc.
4. Formaldehyde reacts with phenol and melamine to form the corresponding condensation polymer products. The condensation polymerisation progresses through step by step and is called also step growth polymerisation.
5. Nylon, bakelite and dacron are some of the important examples of condensation polymers.
6. A condensation of two different unsaturated monomers exhibits copolymerisation. A copolymer like Buna-S contains multiple units of 1, 3-Butadiene and styrene.
7. Natural rubber is cis-1, 4-polyisoprene. It can be made more tough by the process of vulcanization with sulphur.
8. Synthetic rubbers like Buna-N are usually obtained by copolymerisation of alkene and 1, 3-Butadiene derivatives.
9. In view of potential environmental hazards of synthetic polymeric wastes, certain biodegradable polymers such as PHBV and Nylon-2-Nylon-6 are developed as alternatives.

QUESTIONS

VSA TYPE QUESTIONS (1 - MARK QUESTIONS)

1. Define the term copolymer.
2. Identify homopolymer from the following examples Nylon-66, Nylon-6, Nylon-2-Nylon-6.
3. Give example of a natural polyamide which is an important constituent of diet.

[Hint : Proteins]

4. Classify polythene and bakelite as thermosetting plastics or thermoplastics.
5. Among fibres, elastomers and thermosetting polymers, which one has strongest intermolecular forces of attraction?
6. Why is bakelite called a thermosetting polymer.
7. Give the monomers of bakelite.
8. Identify the monomer in the following polymeric structure.

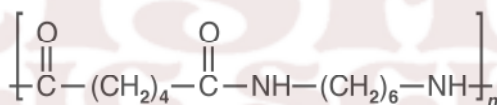

9. Nylon-2-Nylon-6 is a biodegradable polymer obtained from glycine, $\text{H}_2\text{N} - \text{CH}_2 - \text{COOH}$ and aminocaproic acid, $\text{H}_2\text{N} - (\text{CH}_2)_5 - \text{COOH}$. Write the structure of this polymer.
10. Give two uses of teflon.
11. Name the polymer used for making insulation material for coating copper wire. [Hint : PVC].
12. Write the name and structure of monomer of the polymer which is used as synthetic wool.
13. How is vulcanized rubber obtained?
14. Name the polymer used for making radio television cabinets and feeding bottles of children.
15. What do the digits 6 and 66 represent in the names nylon-6 and nylon-66?
16. Write the full form of PHBV.

17. Which of the following sets has all polymers capable of repeatedly softening on heating and hardening on cooling?
- Glyptal, Melamine, PAN.
 - PVC, Polystyrene, polythene.
 - Polypropylene, urea formaldehyde resin, teflon.
- *18. Why benzoyl peroxide is used as an initiator for chain growth polymerisation?
 [Hint : It easily generates free radicals required for initiation of reaction.]

SA (I) TYPE QUESTIONS (2 - MARK QUESTIONS)

- Give the structure of monomer of neoprene. What is the advantage of neoprene over the natural rubber?
- Classify the following as homopolymer or copolymer. Also classify them as addition or condensation polymers.
 - $-(\text{NH CH (R) CO})_n-$
 - $-(\text{CH}_2 - \text{CH} = \text{CH} - \text{CH}_2 - \underset{\text{C}_2\text{H}_5}{\text{CH}} - \text{CH}_2)_n$
- Give the mechanism of polymerisation of ethene to polythene in presence of benzoyl peroxide.
- Complete the following reactions :

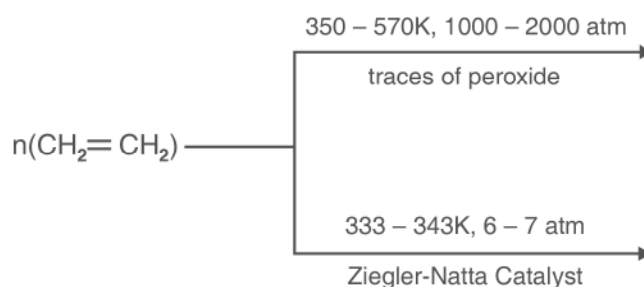

- What is the difference between step growth polymer and chain growth polymer?
 - Give one example of each type.

6. How can you differentiate between thermosetting and thermoplastic polymers.
7. Mention the type of intermolecular forces present in nylon-66. What properties do they impart to nylon?

[Hint : Strong intermolecular forces of attraction like Hydrogen bonding. This results in close packing of chains and thus impart crystalline nature to the fibres.]

8. What is the difference between linear chain and branched chain polymers. Explain giving examples.
9. Identify the polymer whose structure are given and mention one of their important use.

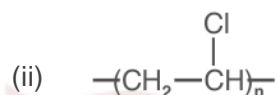
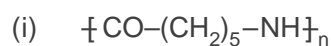

10. Arrange the following polymers in the order of increasing intermolecular forces :
 - (i) Nylon-6,6, Buna-S, Polythene.
 - (ii) Nylon-6, Neoprene, Polyvinylchloride
11. Write the expanded form and give the structures of monomers for the following polymers:
 - (i) PAN
 - (ii) PTFE
12. Novolac is the linear polymer which on heating with formaldehyde forms cross-linked bakelite. Write the structures of monomers and the polymer novolac.
13. Write the structure of following polymers and also give their main uses :
 - (a) Polystyrene
 - (ii) Melamine - formaldehyde resin.
14. Identify the polymers used in the manufacture of paints and lacquers. Write the structure of the polymer and its monomers.
15. Can a copolymer be formed by both addition and condensation polymerisation? Explain with the help of examples.

Unit - 16

CHEMISTRY IN EVERYDAY LIFE

Points to Remember

1. A drug is a chemical agent which affects human metabolism and provides cure from ailment. If taken in doses higher than recommended, these may have poisonous effect.
2. Use of chemicals for therapeutic effect is called chemotherapy.
3. Drugs usually interact with biological macromolecules such as carbohydrates, proteins, lipids and nucleic acids. These are called target molecules.
4. Drugs are designed to interact with specific targets so that these have the least chance of affecting other targets. This minimises the side effects and localises the action of the drug.
5. Drugs like analgesics, antibiotics, antiseptics, disinfectants, antacids and tranquilizers have specific pharmacological functions.
6. Antifertility drugs are used to control population. These contain a mixture of synthetic estrogen and progesterone derivatives.
7. Chemicals are added to food for preservation, enhancing their appeal and adding nutritive value in them.
8. Artificial sweetening agents like aspartame, saccharin etc. are of great value to diabetic persons and people who need to control their calories.
9. These days detergents are much in vogue and get preference over soaps because they work even in hard water.
10. Synthetic detergents are classified into three main categories namely anionic, cationic and non-ionic.
11. Detergents with straight chain of hydrocarbons are preferred over branched chain as the latter are non-biodegradable and consequently cause environmental pollution.
12. The unbranched hydrocarbon side chains of the detergent molecule are prone to attack by bacteria, so the detergents are bio-degradable and pollution is prevented.

VSA QUESTIONS (1 - MARK QUESTIONS)

1. Write the formula and IUPAC name of aspirin.

[Hint :

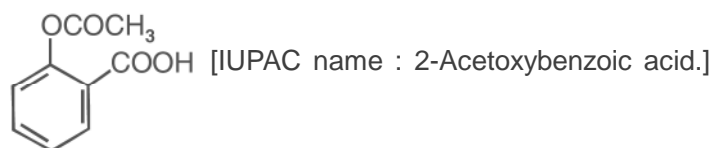

2. Name two types of the drugs classified on the basis of pharmacological effect.
3. What is the role of Bithional in toilet soaps?
4. Why is sodium benzoate added to packed containers of jams and pickles?
5. Name the type of drugs having following structural formula :

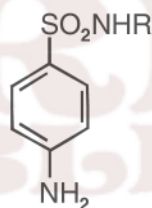

[Hint : Sulpha Drugs].

6. Why the receptors embedded in cell membranes show selectivity for one chemical messenger over the other?

[Hint : The active site of receptor has specific shape and specific functional groups which can bind only specific messenger which fits in.]

7. With reference to which classification has the statement 'ranitidine is an antacid' been given?

[Hint : Classification based on pharmacological effect.]

8. Give the name of medicine used for the treatment of syphilis.

[Hint : Salvarsan].

9. Give the composition of tincture of iodine.

10. How does aspirin act as analgesic?

[Hint : Aspirin inhibits the synthesis of prostaglandins which cause pain.]

11. Name the antiseptic agents present in dettol.
[Hint : Chloroxylenol and Terpeneol].
12. What precaution should be taken before administrating penicillin to a patient?
[Hint : To confirm, beforehand that the patient is not allergic to penicilin.]
13. Explain why aspirin finds use in prevention of heart attacks?
[Hint : Due to anti blood clotting activity.]
14. Mention one use of drug meprobamate.
[Hint : Antidepressant drug.]
15. Name the derivative of sucrose which tastes like sugar and can be safely used by weight conscious people.
16. Why synthetic detergents are preferred over soaps for use in washing machines?
[Hint : They work well even with hard water and not form any scum.]
- *17. How is acidity cured with cimetidine?
[Hint. : Cimetidine prevents the interaction of histamines with the receptors present in stomach wall.]
- *18. While antacids and antiallergic drugs interfere with the function of histamines, why do these not interfere with the function of each other?
[Hint. : Antacids and antiallergic drugs bind to the different receptor sites. Therefore, they do not interfere with the function of each other).]
19. Which of the following two compounds can be used as a surface agent and why?

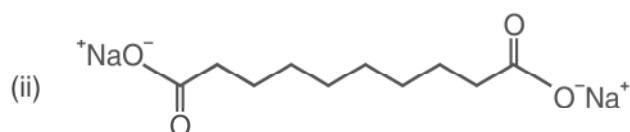
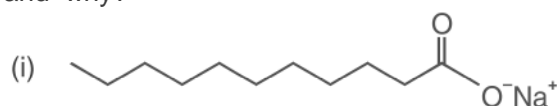

[Hint : Compound (i) acts as a surface agent because its one end is hydrophobic while the other end is hydrophilic in nature.]

20. What type of drug is chloramphenicol?
21. Name a chemical used as an antiseptic as well as disinfectant.
22. Give two examples of antidepressants.

SA (I) TYPE QUESTIONS (2 - MARK QUESTIONS)

1. What are antihistamines. Give two examples.
2. What are narcotic and non-narcotic analgesics? Give one example of each.
3. Explain the following terms as used in medicinal chemistry :
 - (i) Target molecules
 - (ii) Enzyme inhibitors.
4. Give one important use of each of following :
 - (i) Equanil
 - (ii) Morphine
5. What are neurologically active drugs. Give two examples.
6.
 - (i) What are antibiotics?
 - (ii) What is meant by the term broad spectrum antibiotic?
7. From the given examples ciprofloxacin, phenelzine, morphine, ranitidine. Choose the drug used for
 - (i) treating allergic conditions
 - (ii) to get relief from pain
8. Why a drug should not be taken without consulting a doctor? Give two reasons.
9. State the main difference between bacteriostatic and bacteriocidal antibiotics. Give one example of each.
10. What are antifertility drugs? Name the constituents of an oral contraceptive.
11. What do you mean by non-biodegradable detergents? How can we make biodegradable detergents?
- *12. If water contains dissolved calcium hydrogencarbonate, which out of soap and detergent, will you prefer to use? Why?
[Hint : We will use detergent because it will not form insoluble precipitate with Ca^{2+}]
- *13. What are barbiturates? What is the action of barbiturates on human body?
[Hint : Barbituric acid derivatives are called barbiturates. They are highly effective pain relieving agents.]
- *14. Write the structures of soaps obtained by the hydrolysis of following fats:
 - (i) $(\text{C}_{15}\text{H}_{31}\text{COO})_3\text{C}_3\text{H}_5$ Glycerol palmitate
 - (ii) $(\text{C}_{17}\text{H}_{33}\text{COO})_3\text{C}_3\text{H}_5$ Glycerol oleate.
[Hint : (i) $\text{C}_{15}\text{H}_{31}\text{COO}^-\text{Na}^+$ (ii) $\text{C}_{17}\text{H}_{33}\text{COO}^-\text{Na}^+$]

SA (II) TYPE QUESTIONS (3 - MARK QUESTIONS)

- Why are artificial sweetening agents harmless when taken?
 - Name one such artificial sweetening agent.
 - Why is the use of aspartame as an artificial sweetener limited to cold foods?
- Pick out the odd one amongst the following on the basis of their medicinal properties. Give suitable reason.
 - Luminal, seconal, terfenadine, equanil.
 - Chloroxylenol, phenol, chloramphenicol, bithional.
 - Sucralose, aspartame, alitame, sodium benzoate.

[Hint :

- Terfenadine is antihistamine other three are used as tranquilisers.
 - Chloramphenicol is a broad spectrum antibiotic. Other three have antiseptic properties.
 - Sodium benzoate is a food preservative. Other three are artificial sweeteners.]
- Give the main function of following in the body of human beings.
 - Enzymes
 - Receptor proteins
 - Neurotransmitter
 - Identify the class of drug :
 - Phenelzine (Nardin)
 - Aspirin
 - Cimetidine
 - Give the pharmacological function of the following type of drugs:
 - Analgesics
 - Tranquilizers
 - Antifertility drugs

6. Give the name of medicine used in the treatments of following diseases:
- Typhoid
 - Joint pain (in Arthritis)
 - Hypertension
7. Give the class of drugs to which these substances belong :
- Bithional
 - Amoxycillin
 - Salvarsan
8. How are antiseptics different from disinfectants? How does an antibiotic differ from these two? Give one example of each of them.
9. Explain the following terms with suitable examples :
- Cationic detergents
 - Anionic detergents
 - Nonionic detergents
- *10. Label hydrophilic and hydrophobic part in the following compounds :
- $\text{CH}_3(\text{CH}_2)_{10}\text{CH}_2\text{OSO}_3^- \text{Na}^+$
 - $\text{CH}_3(\text{CH}_2)_{15}\text{N}^+(\text{CH}_3)_3 \text{Br}^-$
 - $\text{CH}_3(\text{CH}_2)_{16}\text{COO}(\text{CH}_2\text{CH}_2\text{O})_n\text{CH}_2\text{CH}_2\text{OH}$

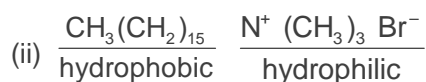
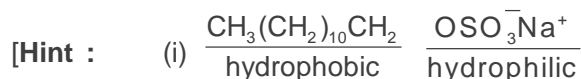

- *11. Classify the following as cationic detergents, anionic detergents or nonionic detergents:
- $\text{CH}_3(\text{CH}_2)_{10}\text{CH}_2\text{OSO}_3^- \text{Na}^+$
 - $[\text{CH}_3 - (\text{CH}_2)_{15}\text{N}(\text{CH}_3)_3]^+ \text{Br}^-$

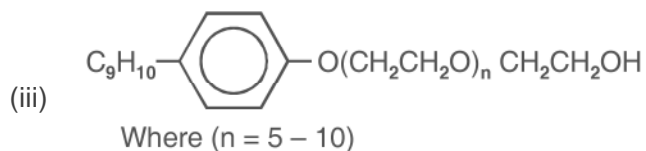

[Hint : (i) Anionic detergent. (ii) Cationic detergent.
(iii) Nonionic detergent.

*12. How do enzyme inhibitors work? Distinguish between competitive and non-competitive enzyme inhibitors.

[Hint : An enzyme inhibitor either blocks the active site of enzyme or changes the shape of the active site by binding at an allosteric site. They are of two types.

- (i) Competitive enzyme inhibitor – It competes with natural substance for their attachment on the active sites of enzymes.
- (ii) Non-competitive enzyme inhibitor binds at allosteric site and changes the shape of the active site in such a way that the substrate can not recognise it.]

MODEL TEST PAPER-I (SOLVED)

(FOR SR. SCHOOL CERTIFICATE EXAMINATION-2012)

Chemistry (Theory)

Time : 3 hours

Total Marks : 70

General Instruction

- (i) All questions are compulsory.
- (ii) Question number 1 to 8 are very short answer questions, carrying 1 mark each. Answer these in one word or about one sentence each.
- (iii) Question number 9 to 18 are short answer questions, carrying 2 marks each. Answer these in about 30 words each.
- (iv) Question number 19 to 27 are short answer questions, carrying 3 marks each. Answer these in about 40 words each.
- (v) Question number 28 to 30 are long answer questions, carrying 5 marks each. Answer these in about 70 words each.
- (vi) Use log table, if necessary.
- (vii) Use of calculator is not permitted.

1. Name the non-stoichiometric point defect responsible for colour in alkali metal halides. 1
2. Write the IUPAC name of coordination isomer of the compound
 $[\text{Co}(\text{NH}_3)_6][\text{Cr}(\text{CN})_6]$ 1
3. Write IUPAC name of the following compound

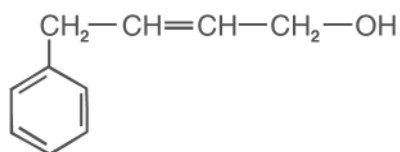

4. Chloroacetic acid has lower pKa value than acetic acid. 1
5. Write the structural formula of N, N-dimethylethanamine. 1
6. What happens when D-glucose is treated with the bromine water? 1
7. How does vulcanisation change the character of natural rubber? 1

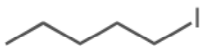
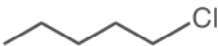
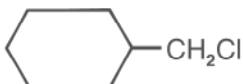
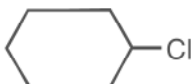
8. Differentiate between antagonists and agonists. 1
9. Explain the following terms with suitable examples :-
 (i) Non-ionic detergents
 (ii) Tranquilizers 2
10. Write the names and structures of the monomers used for getting the following polymers.
 (i) PAN
 (ii) Nylon-6 2
11. Which one in the following pairs undergoes S_N2 reaction faster and why?
 (i)  or 
 (ii)  or 
12. Give suitable reasons for the following :
 (i) Alkyl halides give cyanides with KCN but isocyanide with AgCN.
 (ii) The dipole moment of chlorobenzene is lower than that of cyclohexyl chloride. 2
13. Compare the following complexes with respect to shape and magnetic behaviour
 (i) $[\text{Ni}(\text{CN})_4]^{2-}$
 (ii) $[\text{NiCl}_4]^{2-}$ 2
14. Compare the chemistry of actinoids with that of lanthanoids with special reference to
 (a) oxidation state
 (b) chemical reactivity 2
15. Explain the following terms with a suitable example in each case
 (a) Shape selective catalysts 2
 (b) electroosmosis

Or

15. Write the difference between

- (a) Physisorption and Chemisorption
- (b) Catalyst and enzyme 2
16. What type of cell is the lead storage battery? Write the anode and the cathode reactions and the overall reaction occurring in a lead storage battery while operating or in use. 2
17. Account for the following – 2
- (a) The vapour pressure of a solution of glucose in water is lower than that of pure water.
- (b) Mixture of phenol and aniline shows (–)ve deviation from Raoult's law.
18. Write chemical equations for the preparation of sols : 2
- (a) Gold sol by reduction
- (b) hydrated ferric oxide sol by hydrolysis
19. An element has a bcc structure with a cell edge of 288 pm. The density of the metal is 7.2 g cm^{-3} . How many atoms and unit cells are there in 208g of the element. 3
20. At 300K, two solutions of glucose in water with concentration 0.01M and 0.001 M are separated by semipermeable membrane. On what solution pressure need to be applied to prevent osmosis? Also calculate magnitude of this applied pressure. [$R = 0.821 \text{ L atm mol}^{-1} \text{ K}^{-1}$] 3
21. Calculate the standard cell potential of the galvanic cell in which the following reaction take place :
- $$2\text{Cr(s)} + 3\text{Cd}^{2+}(\text{aq}) \longrightarrow 2\text{Cr}^{3+}(\text{aq}) + 3\text{Cd(s)}$$
- Also calculate $\Delta_r G^\circ$ value for the reaction.
- [Given $E^\ominus_{\text{Cr}^{3+}/\text{Cr}} = -0.74 \text{ V}$; $E^\ominus_{\text{Cd}^{2+}/\text{Cd}} = -0.4 \text{ V}$
- $F = 96500 \text{ C mol}^{-1}$]. 3
22. State briefly the principles which serve as basis for the following operations in metallurgy : 3
- (a) Zone refining
- (b) Vapour phase refining
- (c) Froth floatation process

Or

22. Describe the role of the following :
- Depressant in froth floatation process
 - Cryolite in the metallurgy of aluminium
 - Silica in the extraction of copper from copper pyrites ore. 3
23. Arrange the following in the order of property indicated for each set :
- NH_3 , PH_3 , AsH_3 , SbH_3 , BiH_3 (Decreasing basic strength)
 - F_2 , Cl_2 , Br_2 , I_2 (Increasing bond dissociation enthalpy)
 - H_2O , H_2S , H_2Se , H_2Te (Increasing bond angle) 3
24. Assign reason for the following :
- The enthalpies of atomisation of transition elements are high.
 - The metallic radii of the third (5d) series of transition elements are virtually the same as those of the corresponding members of the second series.
 - With the same d-orbital configuration $[\text{d}^4]$ Cr^{2+} ion is a reducing agent but Mn^{3+} ion is an oxidising agent. 3
25. How will you convert :
- Phenol to ethoxybenzene
 - butan-2-one to but-2-ene
 - 1-propoxypropane to propyl alcohol 3
26. (a) Explain with suitable reasons :
- Gabriel phthalimide synthesis is not used for the synthesis of aniline.
 - Although amino group is *o*, *p*-directing in aromatic electrophilic substitution reactions, aniline on nitration gives a substantial amount of *m*-nitroaniline.
- (b) Identify the A and B in the following reactions :
- $$\text{C}_6\text{H}_5\text{N}_2\text{Cl}^- \xrightarrow[\text{KCN}]{\text{CuCN}} \text{A} \xrightarrow[\text{Partial hydrolysis}]{\text{H}_2\text{O}/\text{H}^+} \text{B}$$
27. (a) How are vitamins classified? Mention the deficiency diseases caused by lack of vitamin A and K.
- (b) Write the zwitter ionic form of amino acids. 3

28. (a) List two main differences between order and molecularity of a reaction.
 (b) A certain reaction is 50% complete in 20 minutes at 300K and the same reaction is again 50% complete in 5 minutes at 350K. Calculate the activation energy if it is a first order reaction

$$(R = 8.314 \text{ J K}^{-1} \text{ mol}^{-1}; \log 4 = 0.6020] \quad 5$$

Or

28. (a) Justify the statement that for a first order reaction half-life period ($t_{1/2}$) is independent of the initial concentration of the reactant.
 (b) For a chemical reaction at 800°C, $2\text{NO} + 2\text{H}_2 \longrightarrow \text{N}_2 + 2\text{H}_2\text{O}$ the following data were obtained.

$[\text{NO}] \times 10^{-4} \text{ mol L}^{-1}$	$[\text{H}_2] \times 10^{-3} \text{ mol L}^{-1}$	Initial rate ($\text{mol L}^{-1} \text{ s}^{-1}$)
1.5	4.0	4.4×10^{-4}
1.5	2.0	2.2×10^{-4}
0.5	2.0	0.24×10^{-4}

What is the order of reaction w.r.t. NO and H_2 ? Also calculate the rate constant at 800°C. 5

29. (a) Assign reasons for the following :
- H_3PO_2 and H_3PO_3 act as good reducing agents while H_3PO_4 does not.
 - ICl is more reactive than I_2 .
 - H_2S is less acidic than H_2Te .
- (b) Draw the structure of
- XeOF_4
 - $\text{H}_2\text{S}_2\text{O}_7$

5

Or

29. (a) Complete the following chemical equations
- $\text{P}_4(\text{s}) + \text{NaOH}(\text{aq}) + \text{H}_2\text{O}(\text{l}) \longrightarrow$
 - $\Gamma^-(\text{aq}) + \text{H}_2\text{O}(\text{l}) + \text{O}_3(\text{g}) \longrightarrow$
- (b) Assign a reason for each of following :
- Bi(V) is a stronger oxidising agent than Sb(V).
 - Fluorine does not exhibit any positive oxidation state.
 - In solution of H_2SO_4 in water, the second dissociation constant K_{a2} is less than the first dissociation constant K_{a1} .

30. (a) Describe the following reactions
- (i) Cannizzaro reaction
 - (ii) Cross Aldol condensation
- (b) Give chemical tests to distinguish between :
- (i) Phenol and benzoic acid
 - (ii) Acetophenone and benzophenone
- (c) Arrange the following in increasing order of acid strengths :
- $(\text{CH}_3)_2\text{CHCOOH}$, $\text{CH}_2\text{CH}_2\text{CH}(\text{Br})\text{COOH}$, $\text{CH}_3\text{CH}(\text{Br})\text{CH}_2\text{COOH}$ 5

Or

30. An organic compound (A) $\text{C}_5\text{H}_{10}\text{O}$ gives positive 2, 4-DNP Test. It does not reduce Tollens' reagent but forms an addition compound with sodium hydrogen sulphite. On reaction with iodine in presence of sodium hydroxide, yellow precipitate B and another compound C is formed. On oxidation with KMnO_4 it forms two acids D and E. Identify A, B, C, D and E.

MARKING SCHEME

Q. No.	Value Points	Marks
1.	F-Center or Metal excess defect	1
2.	$[\text{Cr}(\text{NH}_3)_6][\text{Co}(\text{CN})_6]$ Hexaamminechromium (III) hexacyanocobaltate (III)	1
3.	$\begin{array}{c} \text{CH}_2^4 - \text{CH}^3 = \text{CH}^2 - \text{CH}_2^1 - \text{OH} \\ \\ \text{C}_6\text{H}_5 \end{array}$ 4-Phenylbut-2-en-1-ol	1
4.	Chloroacetic acid is stronger acid than acetic acid due to $-I$ effect of chlorine atom. Therefore, it has lower pK_a value.	1
5.	$\begin{array}{c} \text{CH}_3 - \text{CH}_2 - \text{N} - \text{CH}_3 \\ \\ \text{CH}_3 \end{array}$	1
6.	$\begin{array}{ccc} \text{CHO} & & \text{COOH} \\ & \xrightarrow{\text{Br}_2 \text{ water}} & \\ (\text{CHOH})_4 & & (\text{CHOH})_4 \\ & & \\ \text{CH}_2\text{OH} & & \text{CH}_2\text{OH} \\ & & \text{Gluconic acid} \end{array}$	1
7.	In vulcanisation, sulphur forms cross links at the reactive sites of double bonds and thus the rubber gets stiffened.	1
8.	Drugs that bind to the receptor site and inhibit its natural function, are called antagonists. Drugs that mimic the natural messenger by switching on receptor, are called agonists.	1
9.	(a) Non-ionic detergents do not contain any ion in their constitution. One such detergent is formed when stearic acid reacts with polyethylene glycol.	1

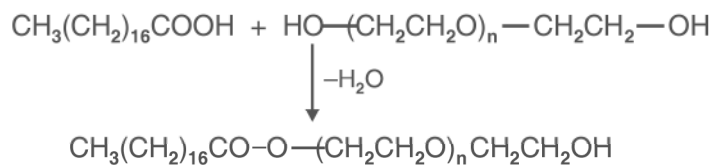

1

(b) Tranquilizers are a class of chemical compounds used for the treatment of stress, and mild or even severe mental diseases, e.g., chlordiazepoxide and meprobamate. 1

10. (a) $\text{CH}_2 = \text{CH} - \text{CN}$
(Acrylonitrile)

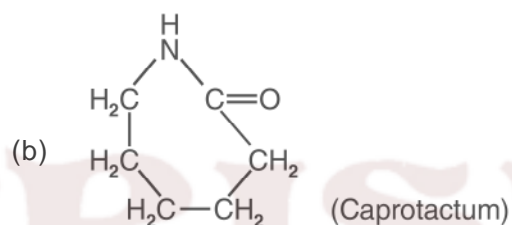

11. (a) 

As iodine is a better leaving group because of its large size, It will be released at a faster rate in the presence of incoming nucleophile. 1

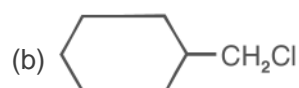

It is primary halide and therefore undergoes $\text{S}_{\text{N}}2$ reaction faster. 1

12. (a) KCN is ionic compound and produces CN^- , so it combines with RX and gives cyanides as major product because of higher bond enthalpy of C-C bond than that of C - N bond, while with AgCN it gives isocyanide due to covalent nature of Ag-C bond by attacking through N atom. 1
- (b) In chlorobenzene carbon is sp^2 hybridised while in cyclohexane it is sp^3 hybridised. Due to the more electronegativity difference in cyclohexyl chloride, its dipole moment is higher than that of chlorobenzene. 1

13. (a) $[\text{Ni}(\text{CN})_4]^{2-}$

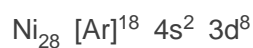

dsp^2 hybridization
(Square Planar)
(Diamagnetic)

1

(b) $[\text{NiCl}_4]^{2-}$

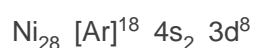

sp^3 hybridization
tetrahedral
(paramagnetic)

1

14. (a) All the lanthanoids exhibit a common stable oxidation state of +3. In addition some lanthanoids also show oxidation states of +2 and +4 where L_n^{2+} and L_n^{4+} have more stable $4f^0$, $4f^7$ or $4f^{14}$ configuration. Members of the actinoids family exhibit more variable oxidation states as compared to the elements belonging to lanthanoids. 1

(b) Actinoids are more reactive than lanthanoids due to bigger size. 1

15. (a) Zeolites are known as shape selective catalysts, because their activity depends on pore size and shape and size of reactant and product molecules. 1

(b) Electroosmosis : When the movement of colloidal particles is prevented by some suitable means, it is observed that the dispersion medium begins to move in an electric field. This phenomenon is called electroosmosis. 1

Or

15. (a) Physisorption have weak van der Waal attraction forces while in chemisorption there are stronger chemical bonds [40 kJ to 200 kJ/mol.] 1

- (b) Almost all the enzymes are globular proteins and used as biochemical catalyst while catalysts are chemical substance used for increasing the rate of chemical reactions. 1
16. (a) Lead storage battery is a secondary battery. $\frac{1}{2}$
 Anode : $\text{Pb(s)} + \text{SO}_4^{2-}(\text{aq}) \longrightarrow \text{PbSO}_4(\text{s}) + 2\text{e}^-$ $\frac{1}{2}$
 Cathode : $\text{PbO}_2(\text{s}) + \text{SO}_4^{2-}(\text{aq}) + 4\text{H}^+(\text{aq}) + 2\text{e}^- \longrightarrow \text{PbSO}_4(\text{l}) + 2\text{H}_2\text{O(l)}$ $\frac{1}{2}$
 Overall reaction :
 $\text{Pb(s)} + \text{PbO}_2(\text{s}) + 4\text{H}^+(\text{aq}) + 2\text{SO}_4^{2-}(\text{aq}) \longrightarrow 2\text{PbSO}_4(\text{s}) + 2\text{H}_2\text{O(l)}$ $\frac{1}{2}$
17. (a) Vapour pressure of pure water gets decreased by addition of nonvolatile glucose, which covers some surface area and lesser surface area is available for vapourisation of water molecules. 1
- (b) In this case the intermolecular hydrogen bonding between phenolic proton and lone pair on nitrogen atom of aniline is stronger than the respective intermolecular hydrogen bonding between similar molecules. 1
18. (a) $2\text{AuCl}_3 + 3\text{SnCl}_2 \longrightarrow 3\text{SnCl}_4 + 2\text{Au}$ (Gold sol). 1
- (b) $\text{FeCl}_3 + 3\text{H}_2\text{O} \longrightarrow \text{Fe}_2\text{O}_3 \cdot \text{XH}_2\text{O} + 3\text{HCl}$ sol 1
19. Volume of the unit cell = $(288 \times 10^{-10} \text{ cm})^3$
 = $2.39 \times 10^{-23} \text{ cm}^3$
- Volume of 208 g of the element = $\frac{\text{Mass}}{\text{Density}} = \frac{208\text{g}}{7.2\text{g cm}^{-3}}$ 1
 = 28.88 cm^3
- No. of unit cells = $\frac{28.88 \text{ cm}^3}{2.39 \times 10^{-23} \text{ cm}^3/\text{unit cell}}$ 1
 = $12.08 \times 10^{23} \text{ unit cells}$
- Since the unit cell is bcc therefore, number of atoms per unit cell is 2
- Total number of atoms in 208 of element = $2 \times 12.08 \times 10^{23}$ 1
 = 24.16×10^{23}

20. (a) For 0.01 M solution

$$\pi_1 = C_1 RT$$

$$\pi_1 = 0.01 \times 0.0821 \times 300 = 0.2463 \text{ atm. } 1$$

For 0.001 M solution.

$$\pi_2 = 0.001 \times 0.0821 \times 300$$

$$= 0.02463 \text{ atm. } .$$

(b) The solvent particles pass from dilute to concentrate solution, i.e., from 0.001M to 0.01 M solution. Therefore, pressure should be applied on 0.01m solution to prevent osmosis. $\frac{1}{2}$

(c) The magnitude of pressure applied = 0.2463 atm
1

21. Cr | Cr³⁺ || Cd²⁺ | Cd

$$E_{\text{cell}}^{\theta} = E_{\text{R}}^{\theta} - E_{\text{L}}^{\theta}$$

$$= -V0.4V - (-V0.74V) = 0.34 \text{ V} \quad 1$$

$$\therefore \Delta G^{\circ} = -nF E_{\text{cell}}^{\theta}$$

$$\Delta G^{\circ} = -6 \times 96500 \text{ C mol}^{-1} \times 0.34 \text{ V} = -6 \times 96500 \times 0.34$$

$$\text{CV mol}^{-1} \quad 1$$

$$\Delta G^{\circ} = -196860 \text{ J mol}^{-1}$$

$$\Delta G^{\circ} = -196.86 \text{ kJ mol}^{-1} \quad 1$$

22. (a) **Zone Refining** : Impure metal rod is heated with circular heater from one end. The metal melts and on cooling the pure metal gets solidified while impurities go into the molten zone. 1

(b) **Vapour Phase Refining** : The metal is converted to a volatile compound which on further heating breaks down to give pure metal.

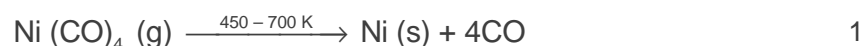
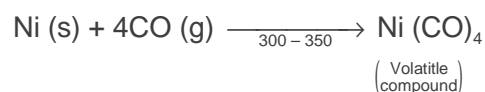

(c) **Froth Floatation Process** : In this process sulphide ore particles are wetted with oil and rise to the surface along with the froth and are separated. The earthy matter wetted by water settles down at the bottom. 1

Or

22. (a) Depressant prevents the formation of froth of one ore in a mixture of two sulphide ores. 1
- (b) Cryolite is added to lower the melting point of the mix and brings conductivity. 1
- (c) Silica is used for removal of FeO as slag, FeSiO_3 in the metallurgy of copper. 1
23. Arrangement of the following compound in the order of property indicated for each set.
- (a) $\text{NH}_3 > \text{PH}_3 > \text{AsH}_3 > \text{SbH}_3 > \text{BiH}_3$ [Decreasing basic strength] 1
- (b) $\text{I}_2 < \text{F}_2 < \text{Br}_2 < \text{Cl}_2$ [Increasing bond dissociation enthalpy] 1
- (c) $\text{H}_2\text{Te} < \text{H}_2\text{Se} < \text{H}_2\text{S} < \text{H}_2\text{O}$ [Increasing bond angle] 1
24. (a) Strong M–M interactions due to participation both ns and (n – 1) d electrons, the enthalpies of atomisation of transition elements are high. 1
- (b) Due to lanthanoid contraction the sizes of 5d series do not increase and remain almost the same as corresponding members of 4d series. 1
- (c) Cr^{2+} is reducing agent because $E^\ominus_{\text{Cr}^{3+}/\text{Cr}^{2+}}$ is negative. This is because of stable configuration of Cr^{3+} ion. On the other hand $E^\ominus_{\text{Mn}^{3+}/\text{Mn}^{2+}}$ is positive due to extra stability of Mn^{2+} which has [Ar] $3d^5$ configuration. 1

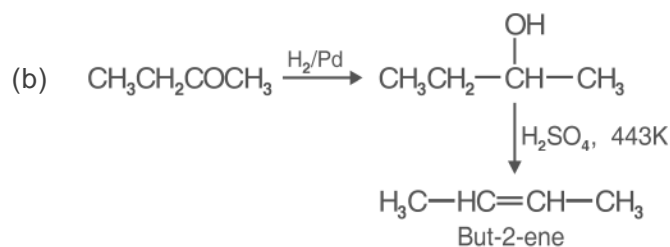
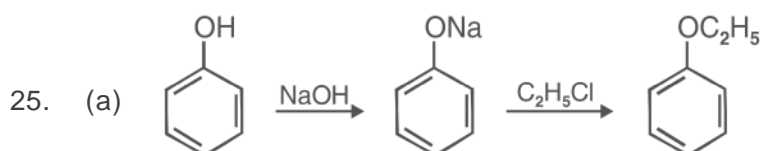

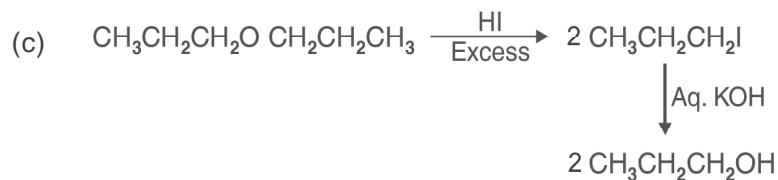

26. (a) Ar-X does not exhibit nucleophilic substitution reaction readily due to partial double bond character of C - X bond, therefore ArNH₂ cannot be prepared by Gabriel phthalimide process. 1
- (b) Amino group is *o*, *p*-directing towards electrophilic substitution reaction but due to the formation of anilinium ion -N⁺H₃ it gives *m*-product also. 1

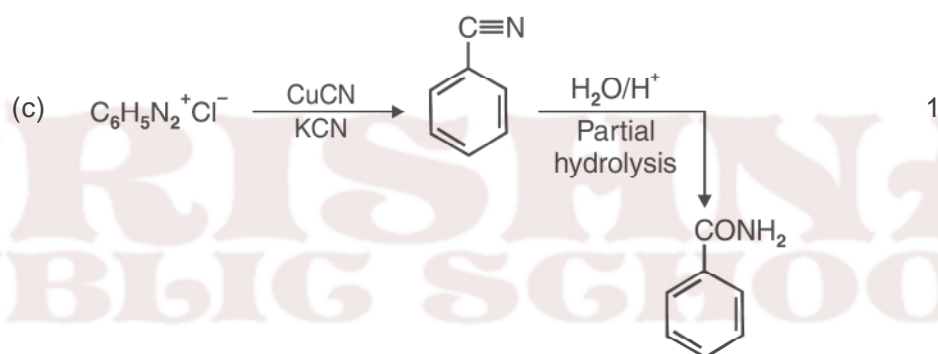

27. (a) Vitamins are broadly classified as water soluble and fat soluble vitamins,
 Water soluble : B, C
 Fat soluble : A, D, E and K 1
 Deficiency disease of vitamin A is night blindness
 Deficiency disease of Vitamin K is increases blood clotting time.
 ½ × 2

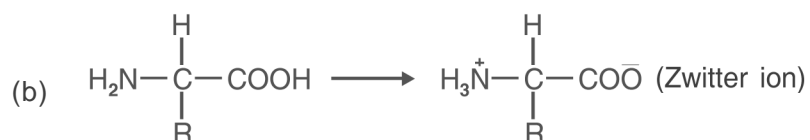

28. (a)

<i>Order of Reaction</i>	<i>Molecularity of Reaction</i>
Order of reaction corresponds to sum of the exponents to which the concentration terms is raised in rate law expression.	Molecularity corresponds to no. of reacting species in elementary reaction.
It may be zero.	It can never be zero.
It may be fractional.	It can never be fractional
It is experimentally determined.	It is a theoretical term. $\frac{1}{2} \times 4$

$$(b) \quad k = \frac{0693}{t_{\frac{1}{2}}} \Rightarrow k_1 = \frac{0693}{20 \text{ min}} = 0.03465 \text{ min}^{-1} \quad \frac{1}{2}$$

$$k_2 = \frac{0693}{5 \text{ min}} = 0.1386 \text{ min}^{-1}$$

$$\log \frac{k_2}{k_1} = \frac{E_a}{2.303R} \left(\frac{1}{T_1} - \frac{1}{T_2} \right)$$

$$\log \left[\frac{0.1386}{0.03465} \right] = \frac{E_a}{2.303 \times 8.314 \text{ JK}^{-1} \text{ mol}^{-1}} \times \left(\frac{1}{300\text{K}} - \frac{1}{350\text{K}} \right)$$

$$E_a = 24205.8 \text{ J mol}^{-1} = 24.2 \text{ kJ mol}^{-1} \quad \frac{1}{2}$$

Or

28. (a) As per first order integrated rate law

$$t = \frac{2.303}{k} \log \frac{[A]_0}{[A]}$$

half-life period $t = t_{1/2}$

$$\text{when } [A] = \frac{[A]_0}{2}$$

$$\Rightarrow t_{1/2} = \frac{2.303}{k} \log \frac{[A]_0}{[A]_0/2} \times 2$$

$$\Rightarrow t_{1/2} = \frac{2.693}{k}$$

It means half life period ($t_{1/2}$) is independent of the initial concentration. 2

(b) According to data using in a hypothetical equation :

$$\text{Rate} = k[\text{NO}]^x [\text{H}_2]^y$$

$$\text{Rate}_1 = 4.4 \times 10^{-4} = k [1.5]^x [4.0]^y$$

$$\text{Rate}_2 = 2.2 \times 10^{-4} = k [1.5]^x [2.0]^y$$

$$\text{Rate}_3 = 0.24 \times 10^{-4} = k [0.5]^x [2.0]^y$$

Compare Rate_1 with Rate_2

$$\frac{\text{Rate}_1}{\text{Rate}_2} = \frac{4.4 \times 10^{-4}}{2.2 \times 10^{-4}} = \frac{k [1.5]^x [4.0]^y}{k [1.5]^x [2.0]^y}$$

$$2 = (2)^y$$

$$y = 1$$

Similarly by comparing Rate_2 and Rate_3

$$3^x = 3^2 \Rightarrow x = 2$$

$$\text{Rate} = k [\text{NO}]^2 [\text{H}_2]^1$$

$$0.24 \times 10^{-4} = k [0.5]^2 \times [2.0]^1$$

$$k = 4.88 \times 10^{-8} \text{ mol}^{-2} \text{ litre}^2 \text{ min}^{-1} \quad 1$$

29. (a) (i) H_3PO_4 exhibit +5 oxidation state which is highest oxidation state for phosphorus, so it does not act as a good reducing agent and also no H is directly attached to P atom. 1
- (ii) I-Cl bond is weaker than I - I bond because the extent of overlapping is less. 1
- (iii) In H_2Te , H-Te bond is weaker than H-S bond in H_2S . So it is more acidic than H_2S . 1

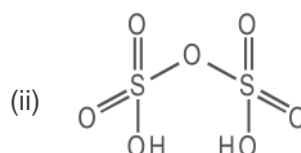
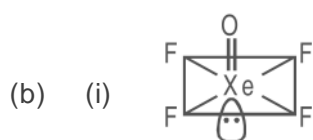

29. (a) (i) $P_4 + 3NaOH + 3H_2O \longrightarrow PH_3 + 3NaH_2PO_2$ 1
- (ii) $2I^- (aq) + H_2O(l) + O_3(g) \longrightarrow 2OH^- + I_2(s) + O_2(g)$ 1
- (b) (i) Bi(V) is stronger oxidising agent due to greater magnitude of inert pair effect as compared to Sb(V) because of more diffused 4f orbitals present in bismuth. 1
- (ii) Fluorine always exhibits -1 oxidation state due to its highest electronegativity (4.0) in the periodic table. 1
- (iii) First ionisation of H_2SO_4 to H_3O^+ and HSO_4^- occurs almost completely. The ionisation of HSO_4^- to H_3O^+ and SO_4^{2-} is very difficult because HSO_4^- is an ionic species. That is why $K_{a2} \ll K_{a1}$. 1

30. (a) (i) Cannizzaro reaction
 $HCHO + HCHO + \text{conc. KOH} \rightarrow CH_3OH + HCOOK$ 1

- (ii) Cross Aldol Condensation

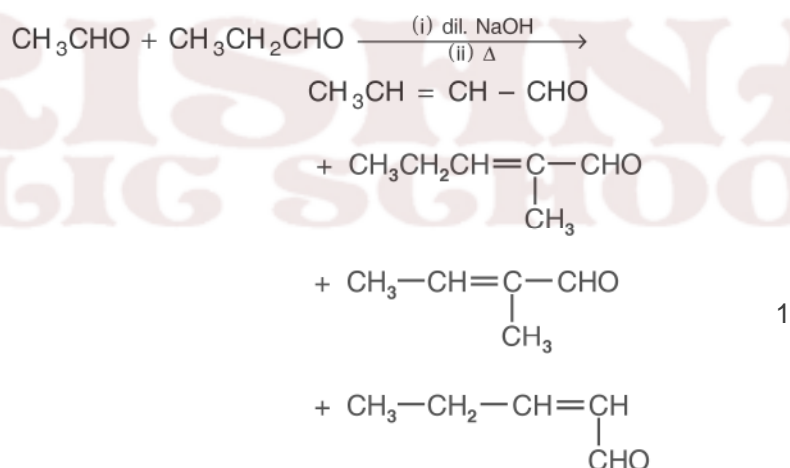

(b)	Phenol	Benzoic acid	
(i)	It does not react with $NaHCO_3$ solution	It gives brisk effervescence of CO_2 gas.	1
(ii)	Acetophenone Add NaOH and I_2 $\xrightarrow{\text{heat}}$ yellow coloured ppt. of CHI_3 is formed.	Benzophenone Add NaOH and $I_2 \xrightarrow{\text{heat}}$ No ppt. is formed	1

(c) Increasing order of acid strengths. $(\text{CH}_3)_2\text{CHCOOH} <$

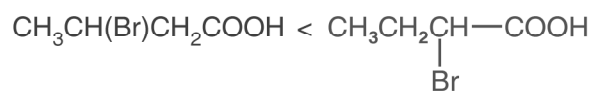

Or

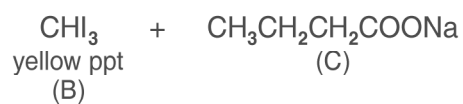
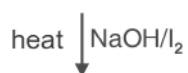
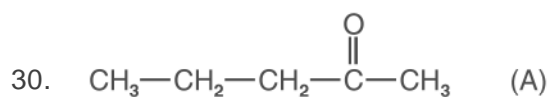

1

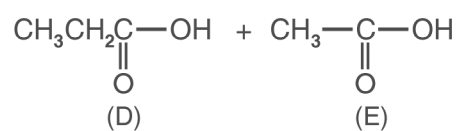
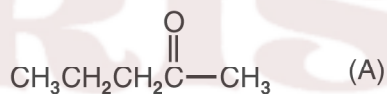

2

MODEL TEST PAPER-II

Chemistry (Theory)

Time : 3 hours

Total Marks : 70

General Instruction

- (i) All questions are compulsory.
- (ii) Question number 1 to 8 are very short answer questions, carrying 1 mark each. Answer these in one word or about one sentence each.
- (iii) Question number 9 to 18 are short answer questions, carrying 2 marks each. Answer these in about 30 words each.
- (iv) Question number 19 to 27 are short answer questions, carrying 3 marks each. Answer these in about 40 words each.
- (v) Question number 28 to 30 are long answer questions, carrying 5 marks each. Answer these in about 70 words each.
- (vi) Use log table, if necessary.
- (vii) Use of calculator is not permitted.

1. 'Crystalline solids are anisotropic in nature.' What does this statement mean?
2. Express the relation between conductivity and molar conductivity of a solution held in a cell.
3. Define 'electrophoresis.'
4. Draw the structure of XeF_2 molecule.
5. Write the IUPAC name of the following compound : $(\text{CH}_3)_3\text{CCH}_2\text{Br}$
6. Draw the structure of 3-methylbutanal.
7. Arrange the following compounds in an increasing order of their solubility in water : $\text{C}_6\text{H}_5\text{NH}_2$, $(\text{C}_2\text{H}_5)_2\text{NH}$, $\text{C}_2\text{H}_5\text{NH}_2$
8. What are biodegradable polymers?
9. The chemistry of corrosion of iron is essentially an electrochemical phenomenon. Explain the reactions occurring during the corrosion of iron in the atmosphere.
10. Determine the values of equilibrium constant (K_C) and Go for the following reaction :

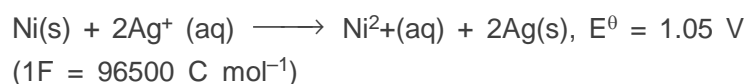

11. Distinguish between 'rate expression' and 'rate constant' of a reaction.
12. State reasons for each of the following :
 - (i) The N – O bond in NO_2^- is shorter than the N – O bond in NO_3^- .
 - (ii) SF_6 is kinetically an inert substance towards hydrolysis.

OR

State reasons for each of the following :

- (i) All the P-Cl bonds in PCl_5 molecule are not equivalent.
 - (ii) Sulphur has greater tendency for catenation than oxygen.
13. Assign reasons for the following :
 - (i) Copper (I) ion is not known in aqueous solution.
 - (ii) Actinoids exhibit greater range of oxidation states than lanthanoids.
 14. Explain the following giving one example for each :
 - (i) Reimer-Tiemann reaction
 - (ii) Friedel – Craft's acetylation of anisole.
 15. How would you obtain
 - (i) Picric acid (2, 4, 6-trinitrophenol) from phenol,
 - (ii) 2-Methylpropene from 2-methylpropanol?
 16. What is essentially the difference between α form of glucose and β form of glucose? Explain.
 17. Describe what you understand by primary structure and secondary structure of proteins.
 18. Mention two important uses of each of the following :
 - (i) Bakelite
 - (ii) Nylon 6
 19. Silver crystallizes in face-centered cubic unit cell. Each side of this unit cell has a length of 400 pm. Calculate the radius of the silver atom. (Assume the atoms just touch each other on the diagonal across the face of the unit cell. That is each, face atom is touching the four corner atoms.)
 20. Nitrogen pentoxide decomposes according to equation : $2\text{N}_2\text{O}_5(\text{g}) \longrightarrow 4\text{NO}_2(\text{g}) + \text{O}_2(\text{g})$.
This first order reaction was allowed to proceed at 40 °C and the data below were collected :

$[\text{N}_2\text{O}_5]/\text{M}$	(M) Time/(min)
0.400	0.00
0.289	20.0
0.209	40.0
0.151	60.0
0.109	80.0

- (a) Calculate the rate constant. Include units with your answer.
- (b) What will be the concentration of N_2O_5 after 100 minutes?
- (c) Calculate the initial rate of reaction.
21. Explain how the phenomenon of adsorption finds application in each of the following processes:
- Production of vacuum
 - Heterogeneous catalysis
 - Froth Floatation process

OR

Define each of the following terms :

- Micelles
 - Peptization
 - Desorption
22. Describe the principle behind each of the following processes :
- Vapour phase refining of a metal.
 - Electrolytic refining of a metal.
 - Recovery of silver ore was leached with NaCN .
23. Complete the following chemical equations :
- $\text{MnO}_4^- + \text{C}_2\text{O}_4^{2-} + \text{H}^+ \longrightarrow$
 - $\text{KMnO}_4 \xrightarrow{\text{heat}}$
 - $\text{Cr}_2\text{O}_7^{2-} + \text{H}_2\text{S} + \text{H}^+ \longrightarrow$

24. Write the name, stereochemistry and magnetic behaviour of the following:
(At.nos. Mn = 25, Co = 27, Ni = 28)
- $K_4 [Mn(CN)_6]$
 - $[Co(NH_3)_5 Cl] Cl_2$
 - $K_2 [Ni(CN)_4]$
25. Answer the following :
- Haloalkanes easily dissolve in organic solvents, why?
 - What is known as a racemic mixture? Give an example.
 - Of the two bromoderivatives,
 $C_6H_5CH(CH_3)Br$ and $C_6H_5CH(C_6H_5) Br$,
which one is more reactive in S_N1 substitution reaction and why?
26. (a) Explain why an alkylamine is more basic than ammonia.
(b) How would you convert
- Aniline to nitrobenzene
 - Aniline to iodobenzene?
27. Describe the following giving one example for each :
- Detergents
 - Food preservatives
 - Antacids
28. (a) Differentiate between molarity and molality for a solution. How does a change in temperature influence their values?
(b) Calculate the freezing point of an aqueous solution containing 10.50 g of $MgBr_2$ in 200 g of water. (Molar mass of $MgBr_2 = 184 \text{ g mol}^{-1}$).
 K_f for water = $1.86 \text{ K kg mol}^{-1}$)
- OR
- Define the terms osmosis and osmotic pressure. Is the osmotic pressure of a solution a colligative property? Explain.
 - Calculate the boiling point of a solution prepared by adding 15.00 g of $NaCl$ to 250.0 g of water. (K_b for water = $0.512 \text{ K kg mol}^{-1}$,
Molar mass of $NaCl = 58.44 \text{ g mol}^{-1}$)

29. (a) Given chemical tests to distinguish between
- propanal and propanone,
 - benzaldehyde and acetophenone.
- (b) How would you obtain
- but-2-enal from ethanal,
 - butanoic acid from butanol,
 - benzoic acid from ethylbenzene?

OR

- (a) Describe the following giving linked chemical equations :
- Cannizzaro reaction
 - Decarboxylation
- (b) Complete the following chemical equations :

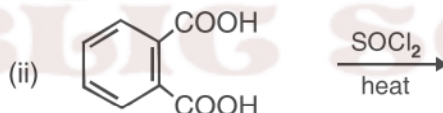
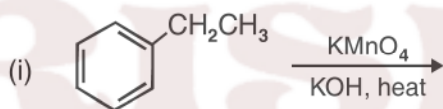

30. (a) Explain the following :
- NF_3 is an exothermic compound whereas NCl_3 is not.
 - F_2 is most reactive of all the four common halogens.
- (b) Complete the following chemical equations :
- $\text{C} + \text{H}_2\text{SO}_4 \text{ (conc)} \longrightarrow$
 - $\text{P}_4 + \text{NaOH} + \text{H}_2\text{O} \longrightarrow$
 - $\text{Cl}_2 + \text{F}_2 \xrightarrow{\text{(excess)}}$

OR

(a) Account for the following :

- (i) The acidic strength decreases in the order $\text{HCl} > \text{H}_2\text{S} > \text{PH}_3$
- (ii) Tendency to form pentahalides decreases down the group in group 15 of the periodic table.

(b) Complete the following chemical equations :

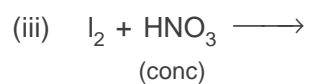
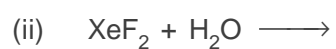

KRISHNA
PUBLIC SCHOOL

MODEL TEST PAPER (III)

Chemistry (Theory)

Time : 3 hours

Total Marks : 70

General Instruction

- (i) All questions are compulsory.
- (ii) Question number 1 to 8 are very short answer questions, carrying 1 mark each. Answer these in one word or about one sentence each.
- (iii) Question number 9 to 18 are short answer questions, carrying 2 marks each. Answer these in about 30 words each.
- (iv) Question number 19 to 27 are short answer questions, carrying 3 marks each. Answer these in about 40 words each.
- (v) Question number 28 to 30 are long answer questions, carrying 5 marks each. Answer these in about 70 words each.
- (vi) Use log table, if necessary.
- (vii) Use of calculator is not permitted.

1. Write a point of distinction between a metallic solid and an ionic solid other than metallic lustre. 1
2. Which one of PCl_4^+ and PCl_4^- is not likely to exist and why? 1
3. What is the role of graphite in the electrometallurgy of aluminium? 1
4. Arrange the following compounds in an increasing order of their reactivity in nucleophilic addition reactions : ethanal, propanal, propanone, butanone.
5. Draw the structural formula of 2-methylpropan -2-ol molecule. 1

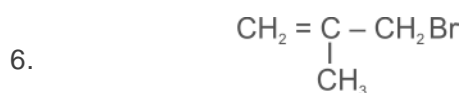

Give the IUPAC name of the following compound.

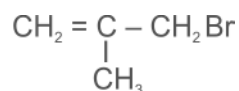

7. Define the term, 'homopolymerisation' giving an example.
8. Arrange the following in the decreasing order of their basic strength in aqueous solutions.

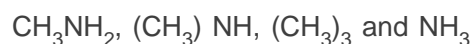

9. A 1.00 molal aqueous solution of trichloroacetic acid (CCl_3COOH) is heated to its boiling point. The solution has the boiling point of 100.18°C . Determine the van't Hoff factor for trichloroacetic acid. (K_b for water = $0.512\text{ K kg mol}^{-1}$)

OR

Define the following terms :

- (i) Mole fraction
 - (ii) Isotonic solutions
 - (iii) Van't Hoff factor
 - (iv) Ideal solution
11. Describe a conspicuous change observed when
- (i) a solution of NaCl is added to a sol of hydrated ferric oxide.
 - (ii) a beam of light is passed through a solution of NaCl and then through a sol.
12. What is meant by coagulation of a colloidal solution? Describe briefly any three methods by which coagulation of lyophobic sols can be carried out.
13. Describe the following :
- (i) The role of cryolite in electro metallurgy of aluminium.
 - (ii) The role of carbon monoxide in the refining of crude nickel.
14. What is meant by (i) peptide linkage (ii) biocatalysts?
15. Explain the following giving an appropriate reason in each case.
- (i) O_2 and F_2 both stabilize higher oxidation states of metals but O_2 exceeds F_2 in doing so.
 - (ii) Structures of Xenon fluorides cannot be explained by Valence Bond approach.
16. Complete the following chemical equations :
- (i) $\text{Cr}_2\text{O}_7^{2-} + \text{H}^+ + \text{I}^- \rightarrow$
 - (ii) $\text{MnO}_4^- + \text{NO}_2^- + \text{H}^+ \rightarrow$
17. Draw the structure of the monomer for each of the following polymers :
- (i) Nylon 6
 - (ii) Polypropene

18. Write the main structural difference between DNA and RNA. Of the two bases, thymine and uracil, which one is present in DNA?
19. Tungsten crystallizes in body centred cubic unit cell. If the edge of the unit cell is 316.5 pm, what is the radius of tungsten atom?

OR

Iron has a body centred cubic unit cell with a cell dimension of 286.65 pm. The density of iron is 7.874 g cm^{-3} . Use this information to calculate Avogadro's number. (At mass of Fe = 55.845u).

20. A solution of glycerol ($\text{C}_3\text{H}_8\text{O}_3$) in water was prepared by dissolving some glycerol in 500 g of water. This solution has a boiling point of 100.42°C while pure water boils at 100°C . What mass of glycerol was dissolved to make the solution?

(K_b for water = $0.512 \text{ K kg mol}^{-1}$)

21. For reaction

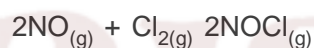

the following data were collected. All the measurements were taken at 263 K:

Experiment No.	Initial [NO]/(M)	Initial [Cl_2]/(M)	Initial rate of disappearance of Cl_2 (M/min)
1	0.15	0.15	0.60
2	0.15	0.30	1.20
3	0.30	0.15	2.40
4	0.25	0.25	?

- (a) Write the expression for rate law.
- (b) Calculate the value of rate constant and specify its units.
- (c) What is the initial rate of disappearance of Cl_2 in exp. 4?
22. State a reason for each of the following situations :
- (i) Co^{2+} is easily oxidized to Co^{3+} in presence of a strong ligand.
- (ii) CO is a stronger complexing reagent than NH_3 .
- (iii) The molecular shape of $\text{Ni}(\text{CO})_4$ is not the same as that of $[\text{Ni}(\text{CN})_4]^{2-}$

23. How would you account for the following?
- With the same d-orbital configuration (d^4) Cr^{2+} is a reducing agent while Mn^{3+} is an oxidizing agent.
 - The actinoids exhibit a larger number of oxidation states than the corresponding members in the lanthanoid series.
 - Most of the transition metal ions exhibit characteristic colours in aqueous solutions.
24. Write chemical equations for the following conversions :
- nitrobenzene to benzoic acid.
 - benzyl chloride to 2-phenylethanamine.
 - aniline to benzyl alcohol.
25. What are the following substances? Give one example of each one of them.
- Tranquilizers
 - Food preservatives
 - Synthetic detergents
26. Draw the structure and name the product formed if the following alcohols are oxidized. Assume that an excess of oxidizing agent is used.
- $\text{CH}_3\text{CH}_2\text{CH}_2\text{CH}_2\text{OH}$
 - 2-butenol
 - 2-methyl-1-propanol
27. Although chlorine is an electron withdrawing group, yet it is ortho-, para-directing in electrophilic aromatic substitution reaction. Explain why it is so? 3
28. (a) complete the following chemical reaction equations :
- $\text{P}_4 + \text{SO}_2\text{Cl}_2 \longrightarrow$
 - $\text{XeF}_6 + \text{H}_2\text{O} \longrightarrow$
- (b) Predict the shape and the asked angle (90° or more or less) in each of the following cases :
- SO_3^{2-} and the angle $\text{O} - \text{S} - \text{O}$

(ii) ClF_3 and the angle $\text{F} - \text{Cl} - \text{F}$

(iii) XeF_2 and the angle $\text{F} - \text{Xe} - \text{F}$

OR

(a) Complete the following chemical equations :

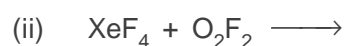
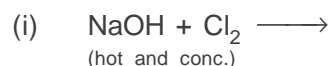

(b) Draw the structure of the following molecules :

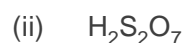
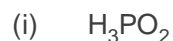

29. (a) What type of a battery is lead storage battery? Write the anode and the cathode reactions and the overall reaction occurring in a lead storage battery when current is drawn from it.

(b) In the button cell, widely used in watches, the following reaction takes place

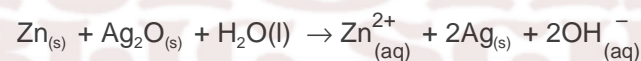

Determine E^\ominus and ΔG^\ominus for the reaction.



OR

(a) Define molar conductivity of a solution and explain how molar conductivity changes with change in concentration of solution for a weak and a strong electrolyte.

(b) The resistance of a conductivity cell containing 0.001 M KCl solution at 298 K is 1500 Ω . What is the cell constant if the conductivity of 0.001 M KCl solution at 298 K is $0.146 \times 10^{-3} \text{ S cm}^{-1}$?

30. Give a plausible explanation for each one of the following :

(i) There are two $-\text{NH}_2$ groups in semicarbazide. However, only one such group is involved in the formation of semicarbazones.

(ii) Cyclohexanone forms cyanohydrin in good yield but 2, 4, 6-trimethylcyclohexanone does not.

- (b) An organic compound with molecular formula $C_9H_{10}O$ forms 2, 4, -DNP derivative, reduces Tollens' reagent and undergoes Cannizzaro's reaction. On vigorous oxidation it gives 1, 2-benzenedicarboxylic acid. Identify the compound.

OR

- (a) Give chemical tests to distinguish between
- phenol and benzoic acid
 - benzophenone and acetophenone
- (b) Write the structures of the main products of following reactions :

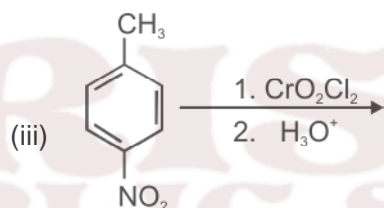
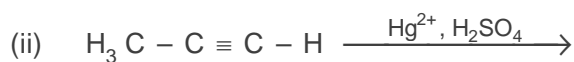
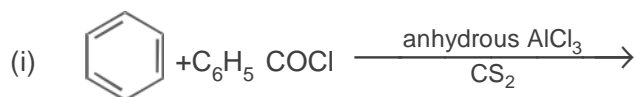

CHEMISTRY

SET I

Time : 3 Hrs.

Max Marks : 70

General Instructions

- All questions are compulsory.
- Question nos. 1 to 8 are very short answer questions and carry 1 mark each.
- Question nos. 9 to 18 are short answer questions and carry 2 marks each.
- Question nos. 19 to 27 are also short answer questions and carry 3 marks each.
- Question nos. 28 to 30 are long answer questions and carry 5 marks each.
- Use log tables if necessary, use of calculators is not allowed.

- Why is ferric chloride preferred over potassium chloride in case of a cut, leading to bleeding? 1
- Why does a tetrahedral complex of the type $[MA_2B_2]$ not show geometrical isomerism? 1
- How do you account for the miscibility of ethoxyethane with water. 1
- Give the IUPAC name of the organic compound
 $(CH_3)_2C=CH-\overset{\overset{O}{\parallel}}{C}-CH_3$
- Name the monomers of nylon 2 or nylon 6 polymer. 1
- Give one example of an artificial sweetener used by the diabetic patients. 1
- Direct nitration of aniline is not carried out. Explain why? 1
- What type of linkage holds together the monomers of D.N.A.? 1
- Examine the illustration of a portion of the defective crystal given below and answer the following questions.

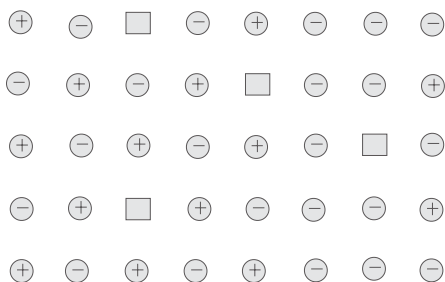

- What are these type of vacancy defects called?
- How is the density of a crystal affected by these defects?

(iii) Name one ionic compound which can show this type of defect in the crystalline state.

(iv) How is the stoichiometry of the compound affected? 2

10. Analysis shows that a metal oxide has the empirical formula $M_{0.96}O_{1.00}$. Calculate the percentage of M^{2+} and M^{3+} ions in this crystal? 2

OR

In an ionic compound the anion (N^-) form cubic close type of packing. While the cation (M^+) ions occupy one third of the tetrahedral voids. Deduce the empirical formula of the compound and the co-ordination number of (M^+) ions. 2

11. Given below is the sketch of a plant for carrying out a process.

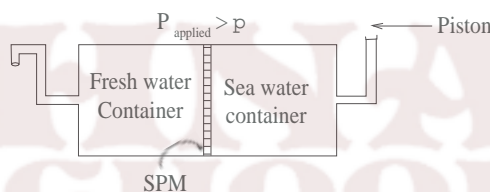

- Name the process occurring in the above plant.
 - To which container does the net flow of solvent take place?
 - Name one SPM which can be used in this plant.
 - Give one practical use of the plant. 2
12. Write the chemical equations for all the steps involved in the rusting of iron. Give any one method to prevent rusting of iron. 2
13. A metal ion M^{n+} having d^4 valence electronic configuration combines with three didentate ligands to form a complex compound. Assuming $D_0 > P$
- Draw the diagram showing d orbital splitting during this complex formation.
 - Write the electronic configuration of the valence electrons of the metal M^{n+} ion in terms of t_{2g} and e_g .
 - What type of hybridisation will M^{n+} ion have?
 - Name the type of isomerism exhibited by this complex. 2
14. A mixed oxide of iron and chromium $FeO.Cr_2O_3$ is fused with sodium carbonate in the presence of air

Chemistry - Sample Question Papers and Answers

to form a yellow coloured compound (A). On acidification, the compound (A) forms an orange coloured compound (B), which is a strong oxidising agent. Identify

- (i) The compounds (A) and (B).
- (ii) Write balanced chemical equation for each step. 2

15. An optically active compound having molecular formula $C_7H_{15}Br$ reacts with aqueous KOH to give a racemic mixture of products. Write the mechanism involved for this reaction. 2

16. Write the formula of main product formed in the following chemical reactions.

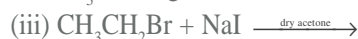

17. Differentiate the following pair of polymers based on the property mentioned against each.

- (i) Novolac and Bakelite (structure).
- (ii) Buna-S and Terylene (intermolecular forces of attraction). 2

18. In order to wash clothes with water containing dissolved calcium hydrogen carbonate, which cleaning agent will you prefer and why: soaps or synthetic detergents? Give one advantage of soaps over synthetic detergents. 2

19. Heptane and octane form an ideal solution at 373 K. The vapour pressures of the pure liquids at this temperature are 105.2 kPa and 46.8 kPa respectively. If the solution contains 25g of heptane and 28.5g of octane, calculate,

- (i) vapour pressure exerted by heptane.
- (ii) vapour pressure exerted by solution.
- (iii) mole fraction of octane in the vapour phase. 3

20. The following chemical reaction is occurring in an electrochemical cell.



The E^0 electrode values are

$$Mg^{2+} / Mg = -2.36 V$$

$$Ag^+ / Ag = 0.81 V$$

For this cell calculate / write

- (a) (i) E^0 value for the electrode: $2Ag^+ / 2Ag$

(ii) Standard cell potential, E^0_{cell} .

(b) Cell potential (E_{cell}).

(c) (i) Symbolic representation of the above cell.

(ii) Will the above cell reaction be spontaneous? 3

21. Consider the adsorption isotherms given below and interpret the variation in the extent of adsorption (x/m) when,

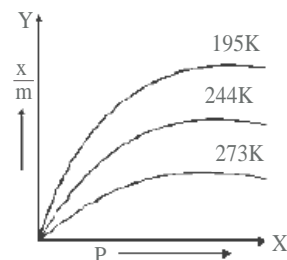

- (a) (i) temperature increases at constant pressure
- (ii) pressure increases at constant temperature
- (b) Name the catalyst and the promoter used in Haber's process for the manufacture of ammonia. 3

22. Account for the following facts.

- (a) The reduction of a metal oxide is easier if the metal formed is in liquid state at the temperature of reduction.
- (b) The reduction of Cr_2O_3 with Al is thermodynamically feasible, yet it does not occur at room temperature.
- (c) Pine oil is used in froth floatation method. 3

23. Explain the following facts.

- (a) Transition metals act as catalysts.
- (b) Chromium group elements have the highest melting points in their respective series.
- (c) Transition metals form coloured complexes. 3

24. (a) Give a chemical test to distinguish between the following pairs of compounds.

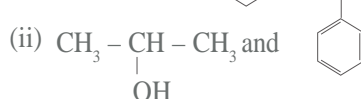
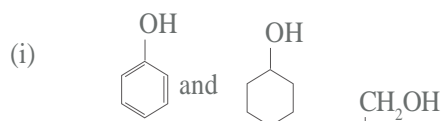

(b) Why is phenol more acidic than ethanol?

25. Account for the following observations

- (i) Among the halogens, F_2 is the strongest oxidising agent?
- (ii) Fluorine exhibits only -1 oxidation state whereas other halogens exhibit higher positive oxidation states also.

Chemistry - Sample Question Papers and Answers

(iii) Acidity of oxoacid of chlorine is
 $\text{HOCl} < \text{HOClO} < \text{HOClO}_2 < \text{HOClO}_3$ 3

26. (a) Give plausible explanation for each of the following.

- (i) The presence of a base is needed in the ammonolysis of alkyl halides.
- (ii) Aromatic primary amines cannot be prepared by Gabriel phthalimide synthesis.
- (b) Write the IUPAC name of

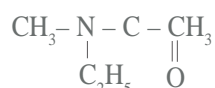

27. An optically active compound having molecular formula $\text{C}_6\text{H}_{12}\text{O}_6$ is found in two isomeric forms (A) and (B) in nature. When (A) and (B) are dissolved in water they show the following equilibrium.



- (i) What are such isomers called?
- (ii) Can they be called enantiomers? Justify your answer.
- (iii) Draw the cyclic structure of isomer (A).

OR

An optically active amino acid (A) can exist in three forms depending on the pH of the medium. If the molecular formula of (A) is $\text{C}_3\text{H}_7\text{NO}_2$ write,

- (i) structure of compound (A) in aqueous medium. What are such ions called?
- (ii) In which medium will the cationic form of compound (A) exist?
- (iii) In alkaline medium, towards which electrode will the compound (A) migrate in electric field? 3

28. For a certain chemical reaction variation in the concentration in $[\text{R}]$ Vs. time (s) plot is given below.

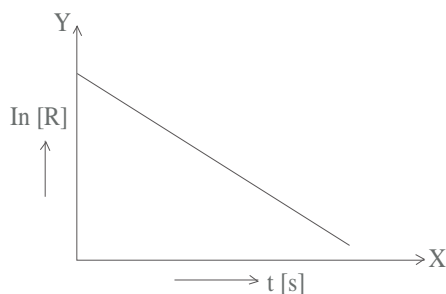

For this reaction write / draw

- (i) What is the order of the reactions?

(ii) What are the units of rate constant k?

(iii) Give the relationship between k and $t_{1/2}$ (half life period).

(iv) What does the slope of the above line indicate?

(v) Draw the plot $\log [R]_0 / [R]$ Vs time t(s) 5

OR

For a certain chemical reaction



The experimentally obtained information is tabulated below.

Experiment	$[\text{A}]_0$	$[\text{B}]_0$	Initial rate of reaction
1	0.30	0.30	0.096
2	0.60	0.30	0.384
3	0.30	0.60	0.192
4	0.60	0.60	0.768

For this reaction,

- (i) Derive the order of reaction with respect to both the reactants A and B.
- (ii) Write the rate law.
- (iii) Calculate the value of rate constant k.
- (iv) Write the expression for the rate of reaction in terms of A and C.

29. A translucent white waxy solid (A) on heating in an inert atmosphere is converted to its allotropic form (B). Allotrope (A) on reaction with very dilute aqueous KOH liberates a highly poisonous gas (C) having rotten fish smell. With excess of chlorine, it forms (D) which hydrolyses to compound (E). Identify compounds (A) to (E). 5

OR

Concentrated sulphuric acid is added followed by heating to each of the following test tubes labelled (i) to (v)

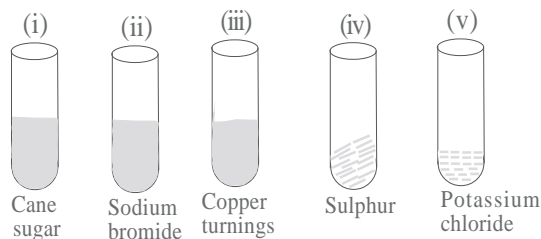

Identify in which of the above test tube the following change will be observed. Support your answer with the help of a chemical equation.

- (a) formation of black substance.
- (b) evolution of brown gas.

Chemistry - Sample Question Papers and Answers

- (c) evolution of colourless gas.
 (d) formation of brown substance which on dilution becomes blue.
 (e) disappearance of yellow powder along with evolution of colourless gas.
30. Identify the unknown organic compounds (A) to (E) in the following series of chemical reactions.

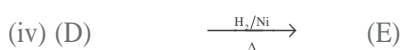
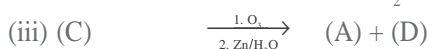
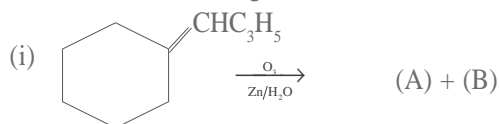

OR

An organic compound (A) having molecular formula C₉H₁₀O forms an orange red precipitate (B) with 2, 4 - DNP reagent. Compound (A) gives a yellow precipitate (C) when heated in the presence of iodine and NaOH along with a colourless compound (D). (A) does not reduce Tollen's reagent or Fehling's solution nor does it decolorise bromine water. On drastic oxidation of (A) with chromic acid, a carboxylic acid (E) of molecular formula C₇H₆O₂ is formed. Deduce the structures of the organic compounds (A) to (E).

SET II

General Instructions same as set 1

- Give IUPAC name of the following organic compound.

$$\text{CH}_3\text{CH}=\underset{\text{CH}_3}{\text{C}}-\underset{\text{Br}}{\text{CH}}-\text{CH}_3$$

1
- What are the physical states of dispersed phase and dispersion medium of froth? 1
- Write the balanced equation for complete hydrolysis of XeF₆. 1
- Write the structure of :
 4 - methyl pent - 3 - en - 2 - one 1
- A compound contains two types of atoms - X and Y. It crystallises in a cubic lattice with atom X at the corners of the unit cell and atoms Y at the body centres. What is the simplest possible formula of this compound? 1

- What is the Van't Hoff factor for a compound which undergoes tetramerisation in an organic solvent? 1
- An ore sample of galena (PbS) is contaminated with zinc blende (ZnS). Name one chemical which can be used to concentrate galena selectively by froth floatation method. 1
- Predict the shape of ClF₃ on the basis of VSEPR theory. 1
- Ethylene glycol (molar mass = 62 g mol⁻¹) is a common automobile antifreeze. Calculate the freezing point of a solution containing 12.4g of this substance in 100 g of water. Would it be advisable to keep this substance in the car radiator during summer?

Given : K_f for water = 1.86 Kkg/mol

K_b for water = 0.512 Kkg/mol 2

10. Consider the reaction A → P. The change in concentration of A with time is shown in the following plot:

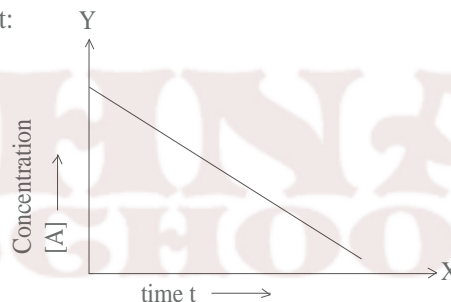

- Predict the order of the reaction.
 - Derive the expression for the time required for the completion of the reaction.
- Free energies of formation (D_fG) of MgO_(s) and CO_(g) at 1273 K and 2273K are given below
 D_fG (MgO_(s)) = - 941 kJ/mol at 1273K
 D_fG (MgO_(s)) = - 314 kJ/mol at 2273K
 D_fG (CO_(g)) = - 439 kJ/mol at 1273K
 D_fG (CO_(g)) = - 628 kJ/mol at 2273K
 On the basis of above data, predict the temperature at which carbon can be used as a reducing agent for MgO_(s). 2
 - Name the two components of starch. How do they differ from each other structurally? 2
 - (a) What changes occur in the nature of egg proteins on boiling?
 (b) Name the type of bonding which stabilises α-helix structure in proteins. 2
 - Describe the mechanism of the formation of

Chemistry - Sample Question Papers and Answers

- diethyl ether from ethanol in the presence of concentrated sulphuric acid. 2
15. Complete and name the following reactions:
 (a) $\text{RNH}_2 + \text{CHCl}_3 + 3\text{KOH} \rightarrow$ 2
 (b) $\text{RCONH}_2 + \text{Br}_2 + 4\text{NaOH} \rightarrow$ 2
16. Give chemical tests to distinguish between compounds in each of the following pairs:
 (i) Phenol and Benzyl alcohol
 (ii) Butane-2-ol and 2-Methyl propan-2-ol 2
17. Predict, giving reasons, the order of basicity of the following compounds in (i) gaseous phase and (ii) in aqueous solutions ($(\text{CH}_3)_3\text{N}$, $(\text{CH}_3)_2\text{NH}$, CH_3NH_2 , NH_3). 2
- OR
- Account for the following:
- (a) Aniline does not undergo Friedel Crafts alkylation
 (b) Although -NH₂ group is an ortho and para-directing group, nitration of aniline gives along with ortho & para derivatives, meta-derivative also.
18. Give reasons for the following :
 (a) At higher altitudes, people suffer from a disease called anoxia. In this disease, they become weak and cannot think clearly.
 (b) When mercuric iodide is added to an aqueous solution of KI, the freezing point is raised. 2
19. An element X with an atomic mass of 60g/mol has density of 6.23 gcm⁻³. If the edge length of its cubic unit cell is 400 pm, identify the type of cubic unit cell. Calculate the radius of an atom of this element. 3
20. Write names of monomer/s of the following polymers and classify them as addition or condensation polymers.
 (a) Teflon (b) Bakelite (c) Natural Rubber 3
21. (a) Give the IUPAC name of :
 $[\text{CrCl}_2(\text{H}_2\text{O})_4]\text{Cl}$
 (b) Give the number of unpaired electrons in the following complex ions: $[\text{FeF}_6]^{4-}$ and $[\text{Fe}(\text{CN})_6]^{4-}$
 (c) Name the isomerism exhibited by the following pair of coordination compounds:
 $[\text{Co}(\text{NH}_3)_5\text{Br}]\text{SO}_4$, $[\text{Co}(\text{NH}_3)_5\text{SO}_4]\text{Br}$
 Give one chemical test to distinguish between these two compounds. 3
22. Explain the following observations.
 (a) Ferric hydroxide sol gets coagulated on addition of sodium chloride solution.
- (b) Cottrell's smoke precipitator is fitted at the mouth of the chimney used in factories.
 (c) Physical adsorption is multilayered, while chemisorption is monolayered. 3
23. Account for the following:
 (a) Chlorine water has both oxidising and bleaching properties.
 (b) H_3PO_2 and H_3PO_3 act as good reducing agents while H_3PO_4 does not.
 (c) On addition of ozone gas to KI solution, violet vapours are obtained. 3
24. The decomposition of $\text{N}_2\text{O}_5(\text{g})$ is a first order reaction with a rate constant of $5 \times 10^{-4} \text{ sec}^{-1}$ at 45° C. ie. $2\text{N}_2\text{O}_5(\text{g}) \rightarrow 4\text{NO}_2(\text{g}) + \text{O}_2(\text{g})$. If initial concentration of N_2O_5 is 0.25M, calculate its concentration after 2 min. Also calculate half life for decomposition of $\text{N}_2\text{O}_5(\text{g})$.
- (b) For an elementary reaction $2\text{A} + \text{B} \rightarrow 3\text{C}$ the rate of appearance of C at time 't' is $1.3 \times 10^{-4} \text{ mol L}^{-1} \text{ s}^{-1}$. Calculate at this time
 (i) rate of the reaction.
 (ii) rate of disappearance of A. 3
25. (a) Which of the following two compounds would react faster by S_N² path way : 1 - bromobutane or 2 - bromobutane and why?
 (b) Allyl chloride is more reactive than n - propyl chloride towards nucleophilic substitution reaction. Explain why.
 (c) Haloalkanes react with KCN to give alkyl cyanide as main product while with AgCN they form isocyanide as main product. Give reason. 3
26. Give reasons for the following:
 (a) CN⁻ ion is known but CP⁻ ion is not known.
 (b) NO₂ dimerises to form N₂O₄
 (c) ICl is more reactive than I₂
- OR
- An element 'A' exists as a yellow solid in standard state. It forms a volatile hydride 'B' which is a foul smelling gas and is extensively used in qualitative analysis of salts. When treated with oxygen, 'B' forms an oxide 'C' which is a colourless, pungent smelling gas. This gas when passed through acidified KMnO₄ solution, decolourises it. 'C' gets oxidised to another oxide 'D' in the presence of a heterogeneous catalyst. Identify A,B,C,D, and also give the chemical equation of reaction of 'C' with

Chemistry - Sample Question Papers and Answers

- acidified KMnO_4 solution and for conversion of 'C' to 'D'.
27. Account for the following:
- Aspirin drug helps in the prevention of heart attack.
 - Diabetic patients are advised to take artificial sweeteners instead of natural sweeteners.
 - Detergents are non-biodegradable while soaps are biodegradable. 3
28. (a) An organic compound 'A' with molecular formula $\text{C}_5\text{H}_8\text{O}_2$ is reduced to n-pentane on treatment with Zn-Hg/HCl . 'A' forms a dioxime with hydroxylamine and gives a positive iodoform test and Tollen's test. Identify the compound A and deduce its structure.
- (b) Write the chemical equations for the following conversions: (not more than 2 steps)
- Ethyl benzene to benzene
 - Acetaldehyde to butane - 1, 3 - diol
 - Acetone to propene 5
- OR
- (a) An organic compound 'A' with molecular formula $\text{C}_8\text{H}_8\text{O}$ gives positive DNP and iodoform tests. It does not reduce Tollen's or Fehling's reagent and does not decolourise bromine water also. On oxidation with chromic acid (H_2CrO_4), it gives a carboxylic acid (B) with molecular formula $\text{C}_7\text{H}_6\text{O}_2$. Deduce the structures of A and B.
- (b) Complete the following reactions by identifying A, B and C.
- $\text{A} + \text{H}_{2(\text{g})} \xrightarrow{\text{Pd/BaSO}_4} (\text{CH}_3)_2\text{CH} - \text{CHO}$
 - $$\text{CH}_3 - \overset{\text{CH}_3}{\underset{\text{CH}_3}{\text{C}}} - \overset{\text{O}}{\parallel}{\text{C}} - \text{CH}_3 + \text{NaOI} \rightleftharpoons \text{B} + \text{C}$$
29. (a) Calculate the equilibrium constant for the reaction
- $$\text{Cd}^{2+}_{(\text{aq})} + \text{Zn}_{(\text{s})} \rightleftharpoons \text{Zn}^{2+}_{(\text{aq})} + \text{Cd}_{(\text{s})}$$
- If $E^0_{\text{cd}^{2+}/\text{cd}} = -0.403 \text{ V}$
- $$E^0_{\text{zn}^{2+}/\text{zn}} = -0.763 \text{ V}$$
- (b) When a current of 0.75A is passed through a CuSO_4 solution for 25 min, 0.369 g of copper is deposited at the cathode. Calculate the atomic mass of copper.
- (c) Tarnished silver contains Ag_2S . Can this tarnish be removed by placing tarnished silver ware in an aluminium pan containing an inert electrolytic solution such as NaCl . The standard electrode potential for half reaction :
- $$\text{Ag}_2\text{S}_{(\text{s})} + 2\text{e}^- \rightleftharpoons 2\text{Ag}_{(\text{s})} + \text{S}^{2-} \text{ is } -0.71\text{V}$$
- and for $\text{Al}^{3+} + 3\text{e}^- \rightleftharpoons \text{Al}_{(\text{s})}$ is -1.66 V
- OR
- (a) Calculate the standard free energy change for the following reaction at 25°C
- $$\text{Au}_{(\text{s})} + \text{Ca}^{2+}_{(\text{aq}, 1\text{m})} \rightleftharpoons \text{Au}^{3+}_{(\text{aq}, 1\text{m})}$$
- $$E^0_{\text{Au}^{3+}/\text{Au}} = +1.50\text{V}$$
- $$E^0_{\text{Ca}^{2+}/\text{Ca}} = -2.87 \text{ V}$$
- Predict whether the reaction will be spontaneous or not at 25°C . Which of the above two half cells will act as an oxidising agent and which one will be a reducing agent?
- (b) The conductivity of 0.001M acetic acid is $4 \times 10^{-5} \text{ S/cm}$. Calculate the dissociation constant of acetic acid, if Λ^0_m for acetic acid is $390.5 \text{ S cm}^2/\text{mol}$.
30. (a) A blackish brown coloured solid 'A' when fused with alkali metal hydroxides in presence of air, produces a dark green coloured compound 'B', which on electrolytic oxidation in alkaline medium gives a dark purple coloured compound C. Identify A, B and C and write the reactions involved.
- (b) What happens when an acidic solution of the green compound (B) is allowed to stand for some time? Give the equation involved. What is this type of reaction called? (3 + 2 = 5)
- OR
- Give reasons for the following:
- Transition metals have high enthalpies of atomisation.
 - Among the lanthanoids, Ce(III) is easily oxidised to Ce(IV).
 - $\text{Fe}^{3+}/\text{Fe}^{2+}$ redox couple has less positive electrode potential than $\text{Mn}^{3+}/\text{Mn}^{2+}$ couple.
 - Copper (I) has d^{10} configuration, while copper (II) has d^9 configuration, still copper (II) is more stable in aqueous solution than copper (I).
 - The second and third transition series elements have almost similar atomic radii. 5

SET III

General instructions same as set 1.

1. Name the type of point defect that occurs in a crystal of zinc sulphide. 1
2. The decomposition reaction of ammonia gas on platinum surface has a rate constant $k = 2.5 \times 10^{-4} \text{ mol L}^{-1} \text{ s}^{-1}$. What is the order of the reaction? 1
3. Give the IUPAC name of the following compound

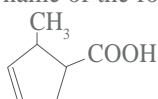

4. How many octahedral voids are there in 1 mole of a compound having cubic close packed structure? 1
5. What is the molecularity of the reaction?

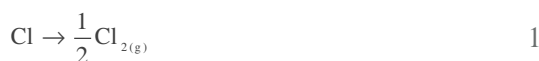

6. In each of the following pairs of organic compounds, identify the compound which will undergo $\text{S}_{\text{N}}1$ reaction faster? 1

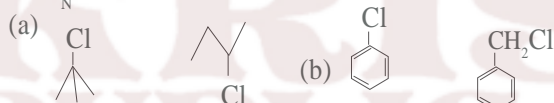

7. In the ring test for identification of nitrate ion, what is the formula of the compound responsible for the brown ring formed at the interface of two liquids? 1
8. Except for vitamin B_{12} , all other vitamins of group B, should be supplied regularly in diet. Why? 1
9. An element E crystallises in body centered cubic structure. If the edge length of the cell is $1.469 \times 10^{-10} \text{ m}$ and the density is 19.3 gm^{-3} , calculate the atomic mass of this element. Also calculate the radius of an atom of this element. 2
10. The following curve is obtained when molar conductivity (Y-axis) is plotted against the square root of concentration (X - axis) for two electrolytes A and B.

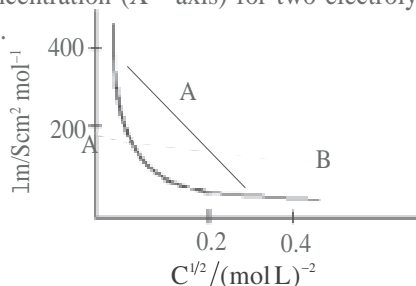

- (a) What can you say about the nature of the two

electrolytes A and B?

- (b) How do you account for the increase in molar conductivity Λ_m for the electrolytes A and B on dilution? 2
- 11 (a) Adsorption of a gas on the surface of solid is generally accompanied by a decrease in entropy. Still it is a spontaneous process. Explain. (b) How does an increase in temperature affect both physical as well as chemical adsorption? 2
12. A colloidal solution of AgI is prepared by two different methods shown below:-

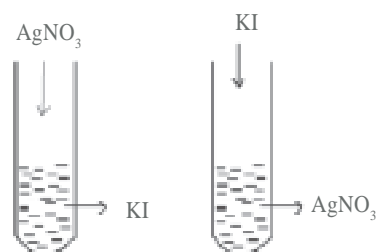

- (i) What is the charge of AgI colloidal particles in the two test tubes (A) and (B)? (ii) Give reasons for the origin of charge. 2
 13. (a) What is the covalence of nitrogen in N_2O_5 ? (b) Explain why both N and Bi do not form pentahalides while phosphorus does. 2
- OR

When conc. H_2SO_4 was added into an unknown salt present in a test tube, a brown gas (A) was evolved. This gas intensified when copper turnings were also added into this test-tube. On cooling, the gas (A) changed into a colourless gas (B).

- (a) Identify the gases A and B. (b) Write the equations for the reactions involved.
14. Which is a stronger acid - Phenol or Cresol? Explain. 2
15. (a) How can you convert an amide into an amine having one carbon less - than the starting compound? (b) Name the reaction. (c) Give the IUPAC name and structure of the amine obtained by the above method if the amide is 3- chlorobutanamide. 2
16. (a) Why does chlorine water lose its yellow colour on standing? (b) What happens when Cl_2 reacts with cold dilute solution of sodium hydroxide? Write equation only. 2

Chemistry - Sample Question Papers and Answers

17. How will you distinguish between:

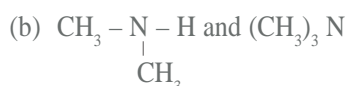
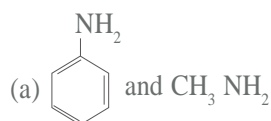

18. Give mechanism of preparation of ethoxyethanol from ethanol. 2

19. (a) A current of 1.50 amp was passed through an electrolytic cell containing AgNO_3 solution with inert electrodes. The weight of Ag deposited was 1.50g. How long did the current flow?

(b) Write the reactions taking place at the anode and cathode in the above cell.

(c) Give reactions taking place at the two electrodes if these are made up of Ag. 3

20.

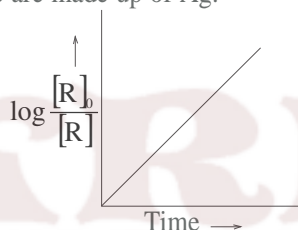

Answer the following questions on the basis of the above curve for a first order reaction A → P:-

(a) What is the relation between slope of this line and rate constant? (1)

(b) Calculate the rate constant of the above reaction if the slope is $2 \times 10^{-4} \text{ s}^{-1}$

(c) Derive the relationship between half life of a first order reaction and its rate constant.

21. (a) Name the method used for refining of

(i) Nickel (ii) Zirconium

(b) The extraction of Au by leaching with NaCN involves both oxidation and reduction. Justify giving equations. 3

22. Write down the equations for hydrolysis of XeF_4 and XeF_6 . Which of these two reactions is a redox reaction? 3

23. Give the electronic configuration of the

(a) d- orbitals of Ti in $[\text{Ti}(\text{H}_2\text{O})_6]^{3+}$ ion in an octahedral crystal field.

(b) Why is this complex coloured? Explain on the basis of distribution of electrons in the d- orbitals.

(c) How does the colour change on heating $[\text{Ti}(\text{H}_2\text{O})_6]^{3+}$ ion? 3

24. (a) Which will have a higher boiling point?

1 - Chloroethane or 2 methyl -2- chlorobutane Give reasons.

(b) p - nitrochlorobenzene undergoes nucleophilic substitution faster than chlorobenzene. Explain giving the resonating structures as well. 3

25. Despite having an aldehyde group

(a) Glucose does not give 2,4 - DNP test. What does this indicate?

(b) Draw the Haworth structure of α - D - (+) - Glucopyranose.

(c) What is the significance of D and (+) here? 3

26.(a) What is the role of Benzoyl peroxide in polymerisation of ethene?

(b) What are LDPE and HDPE? How are they prepared? 3

27. Classify synthetic detergents giving an example in each case.

OR

What are antihistamines? Give two examples. Explain how they act on the human body. 3

28. (a) Derive the relationship between relative lowering of vapour pressure and mole fraction of the volatile liquid.

(b) (i) Benzoic acid completely dimerises in benzene. What will be the vapour pressure of a solution containing 61g of benzoic acid per 500g benzene when the vapour pressure of pure benzene at the temperature of experiment is 66.6 torr?

(ii) What would have been the vapour pressure in the absence of dimerisation?

(iii) Derive a relationship between mole fraction and vapour pressure of a component of an ideal solution in the liquid phase and vapour phase. 5

OR

(a) Which aqueous solution has higher concentration - 1 molar or 1 molal solution of the same solute? Give reason.

(b) 0.5g KCl was dissolved in 100g water and the solution originally at 20°C, froze at - 0.24°C. Calculate the percentage ionisation of salt. K_f per 1000g of water = 1.86K.

29. (a) Out of Ag_2SO_4 , CuF_2 , MgF_2 and CuCl , which compound will be coloured and why?

(b) Explain :

(i) CrO_4^{2-} is a strong oxidising agent while MnO_4^{2-} is not.

Chemistry - Sample Question Papers and Answers

- (ii) Zr and Hf have identical sizes.
 (iii) The lowest oxidation state of manganese is basic while the highest is acidic.
 (iv) Mn (II) shows maximum paramagnetic character amongst the divalent ions of the first transition series.

5

OR

- (a) In the titration of FeSO_4 with KMnO_4 in the acidic medium, why is dil H_2SO_4 used instead of dil HCl ?
 (b) Give reasons:
 (i) Among transition metals, the highest oxidation state is exhibited in oxoanions of a metal.
 (ii) Ce^{4+} is used as an oxidising agent in volumetric analysis.
 (iii) Transition metals form a number of interstitial compounds.
 (iv) Zn^{2+} salts are white while Cu^{2+} salts are blue.
 30. An unknown Aldehyde 'A' on reacting with alkali

gives a β -hydroxy aldehyde, which loses water to form an unsaturated aldehyde, 2-butenal. Another aldehyde 'B' undergoes disproportionation reaction in the presence of conc. alkali to form products C and D. C is an arylalcohol with the formula $\text{C}_7\text{H}_8\text{O}$.

- (i) Identify A and B. (ii) Write the sequence of reactions involved. (iii) Name the product, when 'B' reacts with Zinc amalgam and hydrochloric acid.

OR

A compound 'X' ($\text{C}_2\text{H}_4\text{O}$) on oxidation gives 'Y' ($\text{C}_2\text{H}_4\text{O}_2$). 'X' undergoes haloform reaction. On treatment with HCN 'X' forms a product 'Z' which on hydrolysis gives 2-hydroxy propanoic acid.

- (i) Write down structures of 'X' and 'Y'.
 (ii) Name the product when 'X' reacts with dil NaOH .
 (iii) Write down the equations for the reactions involved.

Answers

SET I

- Fe^{3+} (ferric ion) is a better coagulating ion than K^+ ion.
- In a tetrahedral complexes of the type $[\text{MA}_2\text{B}_2]$, unidentate ligands are equidistant from each other.
- Ethoxyethane is miscible in water because of intermolecular hydrogen bonding between ether and water molecule.
- 4 - Methylpent - 3 - en - 2 - one
- Glycine and aminocaproic acid
 OR
 $\text{H}_2\text{N} - \text{CH}_2 - \text{COOH}$ and $\text{H}_2\text{N} - (\text{CH}_2)_5 - \text{COOH}$
- Saccharin / Aspartame
- During direct nitration of aniline besides ortho, para substituted products, oxidised tarry products and meta substituted products are formed.
- Phosphodiester linkages
- (i) Schottky defects
 (ii) The density of a crystal decreases.
 (iii) Na^+Cl^-
 (iv) Not affected
- The formula $\text{M}_{0.96}\text{O}_{1.00}$ shows that there is 0.96 M atoms are associated with 1 oxygen atom.
 Let number of M^{2+} ions = x.
 Then, number of M^{3+} ions = $(0.96 - x)$

We know that charge of oxygen atom = -2

Then total charge of metal oxide

$$x \times 2 + (0.96 - x) 3 + (1 \times -2) = 0$$

$$\text{ie } 2x + 2.88 - 3x - 2 = 0$$

$$\text{ie } -x + 0.88 = 0; \text{ ie } x = 0.88.$$

$$\% \text{ of } \text{M}^{2+} \text{ ion} = \frac{0.88}{0.96} \times 100 = 91.67\%$$

$$\% \text{ of } \text{M}^{3+} \text{ ion} = \frac{0.08}{0.96} \times 100 = 8.33\%$$

OR

Number of N^- ion in each F.C.C. unit cell = 4

Number of tetrahedral voids = $2 \times 4 = 8$

$$\text{Fraction occupied tetrahedral voids} = \frac{1}{3} \times 8 = \frac{8}{3}$$

Empirical formula of compound = $\text{M}_{8/3} \text{N}_4 = \text{M}_2 \text{N}_3$

Coordination number of M^+ ions = 4

- (i) Reverse osmosis
 (ii) Fresh water container
 (iii) Cellulose acetate placed on a suitable support
 (iv) Desalination of sea water.
- Oxidation : $\text{Fe}_{(s)} \rightarrow \text{Fe}_{(aq)}^{2+} + 2e^-$
 Reduction : $\text{O}_{2(g)} + 4\text{H}_{(aq)}^+ + 4e^- \rightarrow 2\text{H}_2\text{O}$
 Atmospheric oxidation :

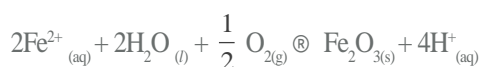

Chemistry - Sample Question Papers and Answers

Prevention : Applying a coating of more reactive metal like Zn.

13. (i)

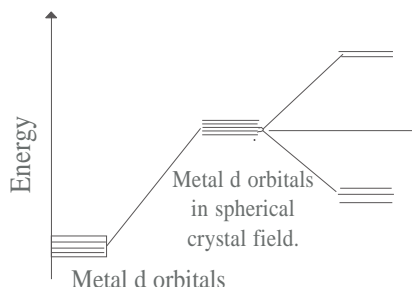

(ii) $t_{2g}^4 e_g^0$ or t_{2g}^4

(iii) d^2sp^3

(iv) Optical isomerism

14. Compound (A) is sodium chromate or Na_2CrO_4
 Compound (B) is sodium dichromate or $\text{Na}_2\text{Cr}_2\text{O}_7$
 $4\text{FeO} \cdot \text{C}_2\text{O}_3 + 8\text{Na}_2\text{CO}_3 + 7\text{O}_2 \rightleftharpoons 8\text{Na}_2\text{CrO}_4 + 2\text{Fe}_2\text{O}_3 + 8\text{CO}_2$
 $2\text{Na}_2\text{CrO}_4 + 2\text{H}^+ \rightleftharpoons \text{Na}_2\text{Cr}_2\text{O}_7 + 2\text{Na}^+ + \text{H}_2\text{O}$

15. Undergoes $\text{S}_{\text{N}}1$ mechanism

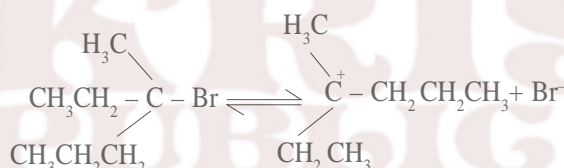

(Optically active)

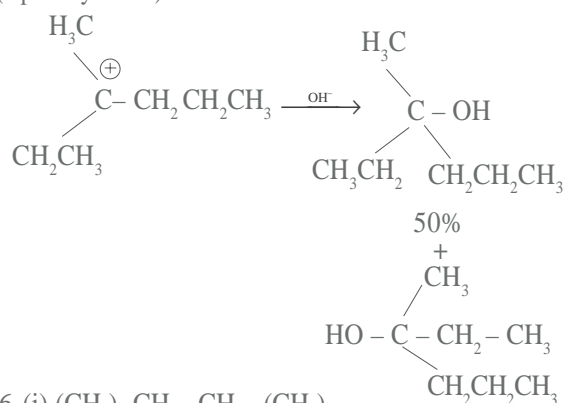

16. (i) $(\text{CH}_3)_2\text{CH} - \text{CH} - (\text{CH}_3)_2$

(ii) CH_3F

(iii) $\text{CH}_3\text{CH}_2\text{I}$

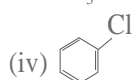

17. (i) Novolac is a straight chain linear polymer but bakelite is cross linked polymer.

(ii) Buna-S is an elastomer having weak van der Waal's intermolecular forces whereas terylene is a fibre

having strong intermolecular hydrogen bonding.

18. Calcium ions form insoluble calcium soaps which separate as scum in water, hence detergents preferred.

Soaps are biodegradable, detergents are not easily biodegradable.

19. Moles of heptane = $\frac{\text{Mass of heptane}}{\text{Molar mass of heptane}}$

$$= \frac{25\text{g}}{100\text{g mol}^{-1}} = 0.25 \text{ moles}$$

Moles of octane = $\frac{\text{Mass of octane}}{\text{Molar mass of octane}}$

$$= \frac{28.5\text{g}}{114\text{g mol}^{-1}} = 0.25 \text{ moles}$$

Total moles = $0.25 + 0.25 = 0.50$ moles

Mole fraction of heptane

$$= \frac{\text{No. of moles of heptane}}{\text{Total No. of moles}} = \frac{0.25}{0.50} = 0.5$$

Mole fraction of octane

$$= \frac{\text{No. of moles of octane}}{\text{Total No. of moles}} = \frac{0.25}{0.50} = 0.5$$

(i) Partial pressure of heptane, $P = p_{\text{heptane}}^0 \times X_{\text{heptane}}$
 $= 105.2 \text{ kPa} \times 0.5 = 52.6 \text{ kPa}$

(ii) Partial pressure of octane, $P = p_{\text{octane}}^0 \times X_{\text{octane}}$
 $= 46.8 \text{ kPa} \times 0.5$
 $= 23.4 \text{ kPa}$

$$\begin{aligned} P_{\text{solution}} &= P_{\text{heptane}} + P_{\text{octane}} \\ &= 52.6 \text{ kPa} + 23.4 \text{ kPa} \\ &= 76.0 \text{ kPa} \end{aligned}$$

(iii) Mole fraction of octane in vapour phase

$$= \frac{P_{\text{octane}}}{P_{\text{solution}}} = \frac{23.4\text{kPa}}{76.0\text{kPa}} = 0.3078$$

20. (a) (i) 0.81 V

(ii) $E_{\text{cell}}^0 = E_{\text{right}}^0 - E_{\text{left}}^0 = 0.81 \text{ V} - (-2.36 \text{ V}) = 3.17 \text{ V}$

(b) $E_{\text{cell}} = E_{\text{cell}}^0 - \frac{0.0591}{n} \log \frac{[\text{Mg}^{2+}]}{[\text{Ag}^+]^2}$

$$= 3.17 - \frac{0.0591}{2} \log \frac{(0.1)}{(0.0001)^2} = 2.96 \text{ V}$$

(c) (i) $\text{Mg}_{(\text{s})} | \text{Mg}^{2+}_{(0.01\text{M})} || \text{Ag}^+_{(0.0001\text{M})} | \text{Ag}_{(\text{s})}$

Chemistry - Sample Question Papers and Answers

- (ii) Yes
21. (a) (i) (x/m) extent of adsorption decreases.
 (ii) (x/m) extent of adsorption increases.
 (b) Catalyst : iron
 Promoter : molybdenum / Al_2O_3 / K_2O
22. (a) In liquid state entropy is higher than the solid form, this makes D_rG more negative.
 (b) By increasing temperature, fraction of activated molecules increase which help in crossing over the energy barriers.
 (c) Pine oil enhances non-wetting property of ore particles and acts as a froth collector.
23. (a) Transition metals acts as catalysts due to their abilities to show multiple oxidation states and form complexes.
 (b) Chromium group elements have maximum number of unpaired electrons in d orbitals because of which maximum d - d interactions are possible. Therefore these elements have the highest melting points in their respective series.
 (c) Transition metals complexes are coloured due to d- d transitions.

24. (a) (i) Add bromine water to both the containers containing phenol and cyclohexanol. The container in which white precipitate is formed contains phenol while the container in which no precipitate is formed contains cyclohexanol.

(ii) Add iodine and sodium hydroxide to both the containers containing $CH_3 - \underset{\text{OH}}{\text{CH}} - CH_3$ (isopropyl alcohol) and $\text{C}_6\text{H}_5\text{CH}_2\text{OH}$ (benzyl alcohol)

The container in which yellow precipitate is formed contains,

$CH_3 - \underset{\text{OH}}{\text{CH}} - CH_3$ while the container in which no yellow precipitate is formed contains $\text{C}_6\text{H}_5\text{CH}_2\text{OH}$

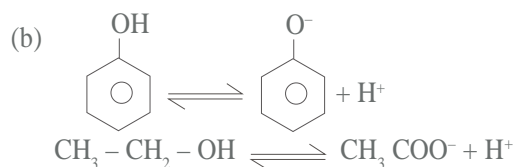

(i) Phenol has electron withdrawing phenyl group, but ethanol has electron releasing ethyl group, hence

extent of forward reaction is higher in phenol in aqueous medium.

(ii) Phenoxide ion is resonance stabilised, ethoxide ion is not resonance stabilised, hence extent of backward reaction is more in ethanol than phenol.

25. (i) Low bond dissociation enthalpy and high hydration (solvation) enthalpy among the halogens.
 (ii) Due to high electronegativity of fluorine atom which exhibits only -1 oxidation state.
 (iii) Higher the oxidation state of chlorine in oxo acid, stronger the acid.
26. (a) (i) To remove HX formed so that the reaction shifts in the forward direction.
 (ii) Aryl halides do not undergo nucleophilic substitution with the anion formed by phthalimide.
 (b) N - ethyl - N - methyl ethanamide.
27. (i) Anomers
 (ii) No, they are not enantiomers because stereoisomers related to each other as non-superimposable mirror images are enantiomers. Anomers differ only at C_1 configuration (or carbonyl carbon).

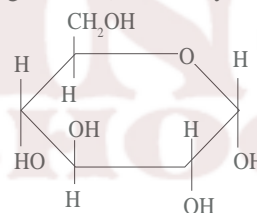

OR

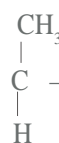

(i) $\text{H}_2\text{N} - \text{C} - \text{C} - \text{O}^-$, Zwitter ion

(ii) Acidic medium (iii) Anode

28. (i) First order

(ii) $\text{time}^{-1} (\text{s}^{-1})$ (iii) $k = \frac{0.693}{t_{1/2}}$

(iv) Rate constant k of reaction.

(v)

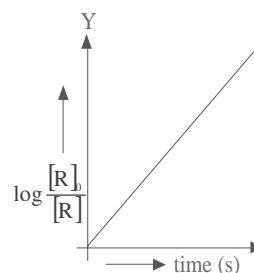

Chemistry - Sample Question Papers and Answers

OR

- (i) Rate = $k [A]^x \times [B]^y$
 $0.096 = k (0.30)^x \times (0.30)^y$ ----- (i)
 $0.384 = k (0.60)^x \times (0.30)^y$ ----- (ii)
 dividing eqn. (ii) by (i), we get $x = 2$
 $0.192 = k (0.30)^x \times (0.60)^y$ ----- (iii)
 dividing eqn. (iii) by (i) we get
 $y = 1$
 (ii) Rate = $k [A]^2 [B]^1$
 (iii) $0.096 = k (0.30)^2 (0.30)^1$
 $k = 3.56$

(iv) Rate of reaction = $-\frac{\Delta[A]}{\Delta t} = \frac{1}{2} \left\{ \frac{\Delta C}{\Delta t} \right\}$



White Red white (C)

(A) (B)

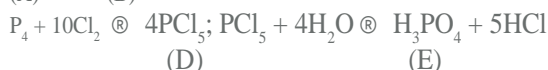

- (A) : white phosphorus
 (B) : red phosphorus
 (C) : phosphine or PH_3
 (D) : phosphorus pentachloride or PCl_5
 (E) : phosphoric acid or H_3PO_4

OR

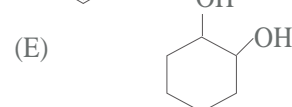
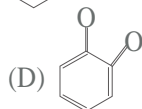
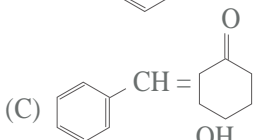
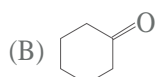
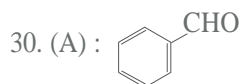
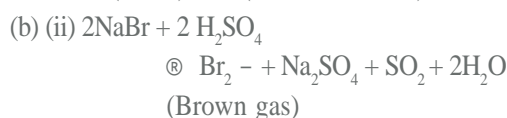

OR

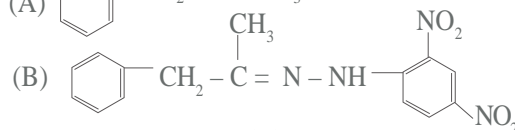
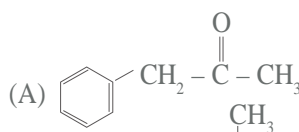

(C) CHI_3 (yellow precipitate)

(D)

(E)

SET II

1. 4 - Bromo - 3- methyl pent - 2- ene.

2. Dispersed phase : gas

Dispersion medium : liquid

3. $XeF_6 + 3H_2O \rightleftharpoons XeO_3 + 6HF$

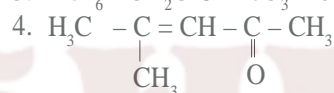

5. XY

6. $i = \frac{1}{4}$

7. NaCN, Sodium cyanide, used as a depressant.

8.

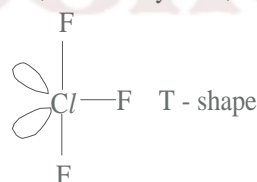

9. $DT_f = K_f \times \frac{W_B}{M_B} \times \frac{1000}{W_A}$

$= 1.86 \times \frac{12.4}{62} \times \frac{1000}{100} = 3.76 \text{ K}$

Since water freezes at $0^\circ C$, so freezing point of the solution containing ethylene glycol will be $-3.76^\circ C$

$DT_b = K_b \times \frac{W_B}{M_B} \times \frac{1000}{W_A}$

$= 0.512 \times \frac{12.4}{62} \times \frac{1000}{100} = 1.024 \text{ K}$

Since water boils at $100^\circ C$, so a solution containing ethylene glycol will boil at $101.024^\circ C$, so it is advisable to keep this substance in car radiator during summer.

Chemistry - Sample Question Papers and Answers

10. (i) The reaction $A \xrightarrow{k} P$ is a zero order reaction.

(ii) For the reaction $A \xrightarrow{k} P$

$$\text{Rate} = \frac{-d[A]}{dt} = k[A]^0$$

$$-d[A] = k dt$$

Integrating both the sides :

$$[A] = kt + C \text{ -----(i)}$$

where C = constant of integration at t = 0,

$$[A] = [A]_0$$

Substituting this in equation (i)

$$C = [A]_0$$

Substituting the value of 'C' in equation (i)

$$[A] = -kt + [A]_0$$

$$kt = [A]_0 - [A]$$

$$t = \frac{[A]_0 - [A]}{k}$$

11. The reaction for reducing action of carbon is :



$$\text{At } 2273\text{K, } \Delta_f G = \Delta_f G(\text{CO}) - \Delta_f G(\text{MgO}) \\ = -628 - (-314) = -314\text{kJ/mol}$$

$$\text{At } 1273\text{K, } \Delta_f G = -439 - (-941) \\ = +502\text{ kJ/mol}$$

So carbon can be used as reducing agent with $\text{MgO}_{(s)}$ at 2273K.

12. The two components of starch are:

(a) Amylose (b) Amylopectin

Amylose is a straight chain polymer of α -D-(+) of glucose, while amylopectin is a branched chain polymer of α -D-(-) glucose.

13. (a) On boiling, protein of egg gets denatured or coagulated and water of egg get absorbed in it.

(b) Hydrogen bonding between $-\overset{\text{O}}{\parallel}{\text{C}}-$ and $-\text{NH}-$ groups of peptide bond.

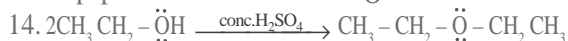

Mechanism:

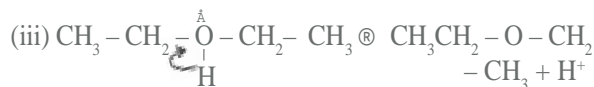
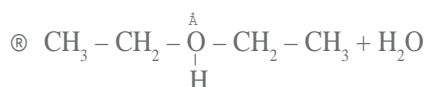
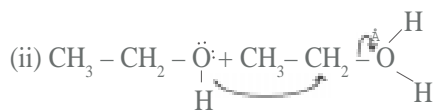
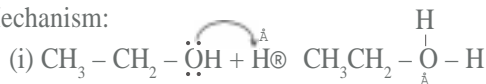

15. (a) $\text{RNH}_2 + \text{CHCl}_3 + 3\text{KOH} \rightleftharpoons \text{RNC} + 3\text{KCl} + 3\text{H}_2\text{O}$
Carbylamine reaction



Hoffmann bromamide degradation reaction

16. (i) Addition of neutral ferric chloride solution to phenol will give a violet colouration, while no such colouration will be observed in case of benzyl alcohol.

(ii) On addition of Luca's reagent (a mixture of concentrated hydrochloric acid and anhydrous zinc chloride) to 2-methyl-2-propanol will give a white turbidity immediately while 2-butanol will give turbidity after five minutes.

17. In gaseous phase, basic character of amines increases with increase in number of electron releasing alkyl groups, due to +I effect, so trend of basic character is $3^\circ > 2^\circ > 1^\circ$. But in aqueous phase, solvation of ammonium cation occurs by water molecules, greater the size of ion, lesser will be the solvation, and lesser will be the stability of ion, so on combining +I effect and solvation effect, in aqueous phase trend changes to $2^\circ > 3^\circ > 1^\circ$.

OR

(a) During Friedal craft's alkylation, aluminium chloride acts as a catalyst, as well as a Lewis acid, it forms salt with $-\text{NH}_2$ group of aniline, so that $-\text{NH}_2$ group acquires a positive charge, and acts as a deactivating group, so aniline does not undergo Friedal Craft's Alkylation.

(b) During nitration, in strongly acidic medium aniline is protonated to form anilinium ion, which is a meta directing group, so along with o- & p- isomers, meta isomer is also obtained.

18. (a) At higher altitudes, partial pressure of oxygen is less than that at ground level, so that oxygen concentration becomes less in blood or tissues. Hence people suffer from anoxia.

(b) Due to the formation of complex $\text{K}_2(\text{HgI}_4)$, number of particles in the solution decreases and hence the freezing point is raised.

$$19. d = \frac{z \times M}{a^3 \times N_A}$$

Chemistry - Sample Question Papers and Answers

$$6.23 = \frac{z \times 60}{(400)^3 \times 10^{-30} \times 6.023 \times 10^{23}}$$

$$z = 4$$

The unit cell is face centered cubic.

$$\text{radius 'r'} = \frac{a}{2\sqrt{2}} = \frac{400}{2\sqrt{2}} = 141.4 \text{ pm}$$

20. (a) Tetrafluoro ethene
Addition polymer
(b) Phenol and formaldehyde
Condensation polymer
(c) Isoprene
Addition polymer
21. (a) Tetraaquadichlorochromium(III) chloride.
(b) $[\text{FeF}_6]^{4-}$ has 4 unpaired electrons as F^- is a weak field ligand.
 $[\text{Fe}(\text{CN})_6]^{4-}$ has zero unpaired electron as CN^- is a strong field ligand.
- (c) Ionisation isomerism. On addition of dilute HCl followed by aqueous BaCl_2 , $[\text{Co}(\text{NH}_3)_5\text{Br}] \text{SO}_4$ will give a white precipitate while the other coordination compound will not give any white precipitate.
22. (a) As ferric hydroxide, $\text{Fe}(\text{OH})_3$ is a positively charged sol, so it gets coagulated by chloride ions, Cl^- , released by NaCl solution.
(b) Cottrell's smoke precipitator, neutralises the charge on unburnt carbon particles coming out of chimney and they get precipitated and settle down at the floor of the chamber.
(c) As physical adsorption, involves only weak van der Waal's force of interaction, so many layers of adsorbate get attached, while chemisorption involves chemical bond formation between adsorbate and adsorbent, so monolayer is formed.
23. (a) Chlorine water produces nascent oxygen which is responsible for bleaching action and oxidation.
 $\text{Cl}_2 + \text{H}_2\text{O} \rightleftharpoons 2 \text{HCl} + [\text{O}]$
(b) Both H_3PO_2 and H_3PO_3 have P-H bonds, so they act as reducing agents, but H_3PO_4 , has no P-H bond but has O-H bonds, so it cannot act as a reducing agent.
(c) Ozone gas acts as a strong oxidising agent, so it oxidises iodide ions to iodine.
 $2\text{I}_{(\text{aq})}^- + \text{H}_2\text{O}_{(l)} + \text{O}_{3(\text{g})} \rightleftharpoons 2 \text{OH}_{(\text{aq})}^- + \text{I}_{2(\text{g})} + \text{O}_{2(\text{g})}$
 I_2 vapours evolved have violet colour.
24. (a) For first order reaction

$$k = \frac{2.303}{t} \log \frac{[\text{R}]_0}{[\text{R}]_t}$$

$$5 \times 10^{-4} = \frac{2.303}{2 \times 60} \log \frac{0.25}{[\text{R}]_t}$$

$$[\text{R}]_t = 0.23 \text{ M}$$

$$t_{1/2} = \frac{0.693}{5 \times 10^{-4}} \text{ sec} = 1386 \text{ sec}$$

$$\text{(b) (i) Rate} = \frac{1}{3} \frac{d[\text{C}]}{dt} = \frac{1}{3} \times 1.3 \times 10^{-4}$$

$$= 0.43 \times 10^{-4} \text{ mol L}^{-1} \text{ sec}^{-1}$$

$$\text{(ii) Rate} = \frac{-d[\text{A}]}{dt} = \frac{2}{3} \times \frac{d[\text{C}]}{dt}$$

$$= 0.86 \times 10^{-4} \text{ mol L}^{-1} \text{ sec}^{-1}$$

25. (a) 1- Bromo butane, being a primary alkyl halide would react faster by $\text{S}_{\text{N}}2$ pathway, due to less steric hinderance.
- (b) In allyl chloride, $\text{CH}_2 = \text{CH} - \text{CH}_2\text{Cl}$, the carbocation $\text{CH}_2 = \overset{\text{+}}{\text{C}}\text{H} - \text{CH}_2$ formed is stabilised due to resonance while the carbocation formed from n - propyl chloride ie. $\text{CH}_3\text{CH}_2\text{CH}_2^+$ is less stable, so allyl chloride is more reactive towards nucleophilic substitution reaction.
- (c) KCN, being ionic, CN^- ions liberated reacts with haloalkanes forming alkyl cyanides but in AgCN , being covalent, does not release CN^- ion but lone pair on nitrogen acts as a nucleophile, resulting in formation of isocyanides.
26. (a) Nitrogen being smaller in size forms pp - pp multiple bonding with carbon, so CN^- ion is known, but phosphorus does not form pp - pp bond as it is larger in size.
(b) Since NO_2 is an odd electron molecule and therefore gets dimerised to stable N_2O_4 .
(c) Because ICl has less bond dissociation enthalpy than I_2 .
- OR
- 'A' = Sulphur
B = H_2S gas
C = SO_2 gas
D = SO_3 gas
 $5\text{SO}_{2(\text{g})} + 2\text{MnO}_4^- + 2\text{H}_2\text{O} \rightleftharpoons 5\text{SO}_4^{2-} + 4\text{H}^+ + 2\text{Mn}^{2+}$
 $2\text{SO}_{2(\text{g})} + \text{O}_{2(\text{g})} \xrightarrow{\text{v.o.s.}} 2\text{SO}_{3(\text{g})}$
27. (a) Due to antiblood clotting action, aspirin is used for prevention of heart attacks.
(b) As artificial sweetners provide less calories than natural sweetners.

Chemistry - Sample Question Papers and Answers

(c) Detergents have highly branched hydrocarbon chain, which cannot be degraded by bacteria, so they get accumulated while soap containing straight hydrocarbon chain can be degraded easily.

28. (a) As 'A' gives positive iodoform test, so it has

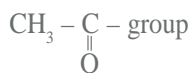

As 'A' gives positive Tollen's test, so it must have -CHO group.

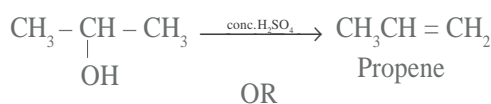
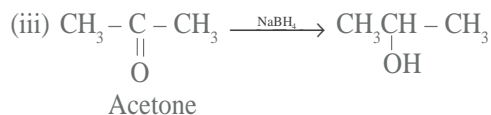
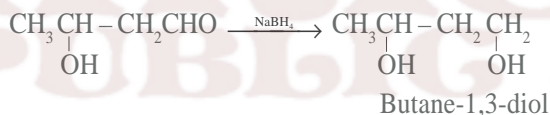
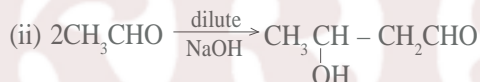
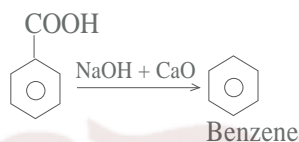
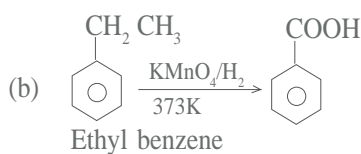
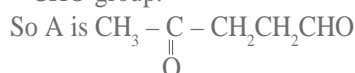

(a) As 'A' does not give Fehling's or Tollen's test, so it does not have -CHO group but it gives positive iodoform test and DNP test so it has $\text{CH}_3 - \underset{\text{O}}{\underset{\parallel}{\text{C}}}$ group.

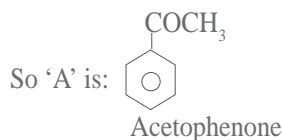

B is carboxylic acid obtained by oxidation of A with H_2CrO_4 .

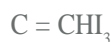
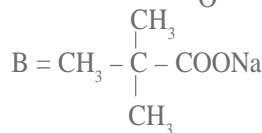
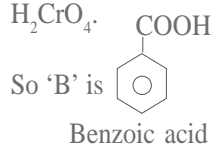

29. (a) $E_{\text{cell}}^{\circ} = E_{\text{c}}^{\circ} - E_{\text{a}}^{\circ} = -0.403 - (-0.763) = 0.360 \text{ V}$

As $\log K_c = \left(\frac{nE_{\text{cell}}^{\circ}}{0.059} \right) = \left(\frac{2 \times 0.360}{0.059} \right)$

$= \left(\frac{0.720}{0.059} \right) = 12.20$

$K_c = \text{antilog}(12.20) = 1.585 \times 10^{12}$

(b) $M = ZIt$

$0.369 = \frac{x}{2 \times 96500} \times 0.75 \times 25 \times 60$ (x = molar mass of copper)

$x = 63.3 \text{ g/mol}$.

(c) E_{cell}° for reaction of tarnished silver ware with aluminium pan is

$(-0.71 \text{ V}) - (-1.66 \text{ V})$ ie, +0.95 V

Tarnished silver ware, therefore, can be cleaned by placing it in an aluminium pan E_{cell}° as it is positive.

OR

(a) $E_{\text{cell}}^{\circ} = (-2.87 \text{ V}) - (1.50 \text{ V}) = -4.37 \text{ V}$

$\Delta G_{\text{cell}}^{\circ} = -6 \times 96500 \times -4.37 \text{ V}$

$= +2350.230 \text{ kJ/mol}$

Since $\Delta_r G^{\circ}$ is positive, reaction is non spontaneous.

Au^{3+}/Au half cell will be a reducing agent, Ca^{2+}/Ca half cell will be an oxidising agent.

(b) $\Lambda_m^{\circ} = K \times \frac{1000}{\text{molarity}}$

K = specific conductance

$= \frac{4 \times 10^{-5} \text{ S/cm} \times 1000}{0.001} = 40 \text{ Scm}^2 \text{ mol}^{-1}$

$\alpha = \frac{\Lambda_m}{\Lambda_m^{\circ}}, \quad \alpha = \frac{40}{390.5} = 0.103$

$K_c = \frac{c\alpha^2}{1-\alpha} = \frac{0.001 \times (0.103)^2}{1-0.103} = 1.19 \times 10^{-5}$

30. (a) A = MnO_2



Chemistry - Sample Question Papers and Answers

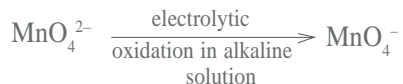

- (b) In acidic medium, K_2MnO_4 changes to give purple coloured compound along with black precipitate.

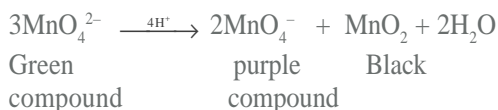

It is called disproportionation reaction.

OR

- (a) Due to strong interatomic interaction between unpaired valence electrons.
 (b) Because Ce(IV) has extrastability due to empty f^0 orbital.
 (c) In Mn^{2+} d^5 configuration leads to extrastability of half filled configuration, so $\text{Mn}^{3+} / \text{Mn}^{2+}$ (d^4) tends to get converted to stable d^5 , configuration of Mn^{2+} , by accepting an electron so $\text{Mn}^{3+} / \text{Mn}^{2+}$ redox couple has more positive potential than couple.
 (d) Due to more negative enthalpy of hydration of $\text{Cu}^{2+}_{(\text{aq})}$ than $\text{Cu}^{+}_{(\text{aq})}$ which compensates for second ionisation enthalpy of copper.
 (e) In the third transition series after lanthanum there is lanthanoid contraction, due to ineffective shielding by intervening f- orbital electrons and hence second and third transition series elements have similar atomic radii.

SET III

- Frenkel defect
- Zero order reaction
- 2 - Methylcyclopent -3- ene carboxylic acid
- 1 Mole or 6.02×10^{23}
- One



- $[\text{Fe}(\text{H}_2\text{O})_5\text{NO}]^{2+}$
- Except for B_{12} , no other vitamin of group B can be stored in the body and is readily excreted in urine.

$$d = \frac{zM}{a^3N_0} \text{ gcm}^{-3}$$

$$a = 1.469 \times 10^{-10} \text{ m} = 146.9 \times 10^{-10} \text{ cm}$$

$$M = \frac{da^3N_0}{z} \text{ g} = \frac{19.3 \times (146.9 \times 10^{-10})^3 \times 6.02 \times 10^{23}}{2}$$

$$= 19.3 \times 3.17 \times 3.01 = 183.5 \text{ g}$$

$$r = 0.634 \times 10^{-8} \text{ cm}$$

- (a) A is a strong electrolyte.
B is a weak electrolyte.
- (b) Molar conductivity of a strong electrolyte increases with dilution as ionic mobility increases. In a weak electrolyte molar conductivity increases steeply with dilution as degree of dissociation increases.
- (a) According to the equation $\text{DG} = \text{DH} - \text{TDS}$ for a process to be spontaneous DG should be negative. Even though DS is negative here, DG is negative because reaction is highly exothermic, i.e., DH is negative.
 (b) On increasing temperature desorption occurs in physical adsorption. Chemical adsorption increases first and then decreases with increase in temperature.
- (i) The AgI colloidal particles in test tube (A) has negative charge.
The AgI colloidal particles in test tube (B) has positive charge.
 (ii) In test tube (A) I^- is adsorbed on Ag . [or AgI / I^- is formed]
 In test tube (B) Ag^+ is adsorbed on AgI . [or AgI / Ag^+ is formed]
- (a) 4
 (b) Unlike P, N has no vacant d-orbitals in its valence shell.
 Bi prefers +3 oxidation state due to inert pair effect.

OR

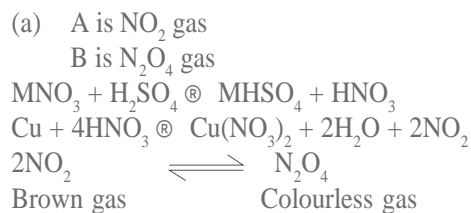

- Phenol is a stronger acid, methyl group due to +I effect concentrates the negative charge on the oxygen, thus destabilising the intermediate phenoxide ion in cresol.
 - (a) By reacting it with NaOH and Br_2 .
 (b) Hoffmann bromamide degradation reaction.
 - (c) 
- 2-Chloropropanamine

Chemistry - Sample Question Papers and Answers

16. (a) Chlorine water loses its yellow colour on standing due to the formation of HCl and HClO.



(cold & dilute)

17. (a) By reacting with NaNO_2 and HCl or HNO_2 at temperature $0-5^\circ\text{C}$, aniline will form diazonium salt; CH_3NH_2 will form methanol and bubbles of N_2 gas will come out of the solution.

(b) By using Hinsberg's reagent. ($\text{C}_6\text{H}_5\text{SO}_2\text{Cl}$)

$(\text{CH}_3)_3\text{N}$ will not react with Hinsberg's reagent while

$(\text{CH}_3)_2\text{NH}$ will form a product insoluble in alkali.

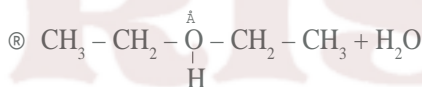
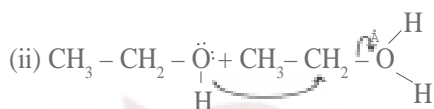
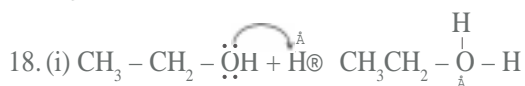

19. (a) According to Faraday's first law, charge required

$$\text{to deposit } 1.50 \text{ g Ag} = \frac{96500}{108} \times 1.50$$

$$= 1331.70 \text{ coulombs}$$

$$\text{Time taken} = \frac{1331.70}{1.50} = 887.15 \text{ sec}$$

(b) Inert electrodes

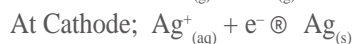

(c) Ag electrodes

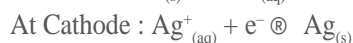
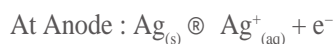

20. (i) $\text{Slope} = \frac{k}{2.303}$

(ii) As slope = $2 \times 10^{-4} \text{ s}^{-1}$

$$k = 2.303 \times 2 \times 10^{-4} \text{ s}^{-1}$$

$$k = 4.606 \times 10^{-4} \text{ s}^{-1}$$

(iii) For a first order reaction $t = \frac{2.303}{k} \log \frac{[\text{R}]_0}{[\text{R}]}$

$$\text{At } t_{1/2}, [\text{R}] = \frac{[\text{R}]_0}{2}$$

$$t_{1/2} = \frac{2.303}{k} \log \frac{[\text{R}]_0}{\frac{[\text{R}]_0}{2}} = \frac{2.303}{k} \log 2$$

$$t_{1/2} = \frac{0.693}{k}$$

21. (a) (i) Mond's Process

(ii) Van Arkel Method

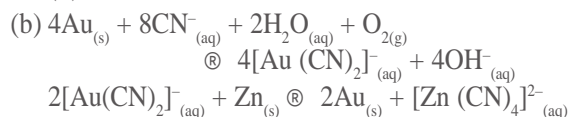

In the first reaction Au changes into Au^+ ie. oxidation takes place. In the second case

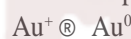

ie, reduction takes place.

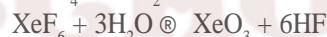

Hydrolysis of XeF_4 is a redox reaction. Here Xe^{4+} is changing into Xe and Xe^{6+}

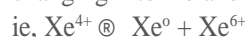

23. (a) In $[\text{Ti}(\text{H}_2\text{O})_6]^{3+}$ ion Ti is in +3 oxidation state.

There is only 1 electron in the d-orbital and its configuration is $t^0_{2g} e^1_g$.

(b) This complex is coloured due to d-d transition, configuration becomes $t^1_{2g} e^0_g$.

(c) On heating $[\text{Ti}(\text{H}_2\text{O})_6]^{3+}$ ion becomes colourless as there is no ligand (H_2O) left in heating. In the absence of ligand, crystal field splitting does not occur.

24. (a) 2-methyl-2-chlorobutane.

Larger molecular mass and has high magnitude of van der Waal forces.

Surface area and hence Van der Waal's forces of attraction decreases on branching.

(b) In nucleophilic substitution reaction, a carbanion intermediate is formed. This is stabilised by resonance as shown below in p-nitrochlorobenzene.

Chemistry - Sample Question Papers and Answers

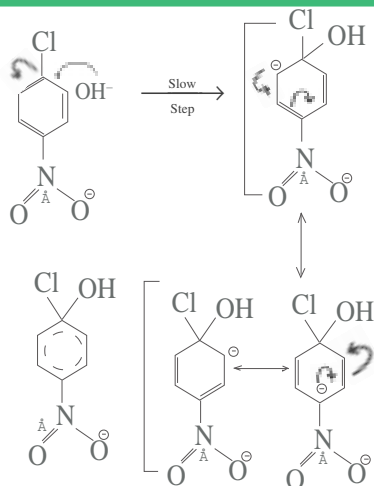

The -I effect of nitro group further stabilizes the intermediate.

Hence p- nitrochlorobenzene reacts faster than chloro benzene.

25. (a) This indicates that the aldehyde group in glucose is not free.

(b)

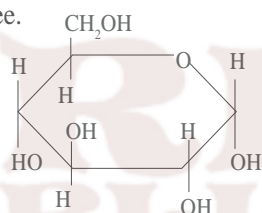

a - D - (+) - Glucopyranose

- (c) 'D' gives the configuration i.e. the - OH group at carbon 5 is on the right hand side (+) indicates that the isomer is dextro rotatory.

26. (a) Benzoyl peroxide working as an initiator in the polymerisation of ethene. It forms a free radical.

- (b) LDPE :- Low Density Polyethylene

LDPE is obtained by the polymerisation of ethene under high pressure of 1000 to 2000 atm at 350K to 570 K temperature in the presence of an initiator.

HDPE:- High Density Polyethylene. It is obtained when polymerisation is done in the presence of Ziegler Natta Catalyst at 333 K to 343 K under 6 - 7 atm pressure.

27. Synthetic detergents are classified into three.

Anionic detergents : These are sodium salts of sulphonated long chain alcohols or hydrocarbons.

Eg : Sodium Salt of alkyl benzene sulphonates.

Cationic detergents : These are quarternary ammonium salts of amines with acetates, chlorides or bromides as anions.

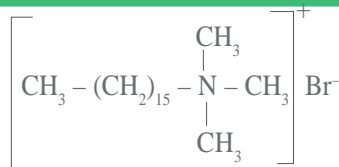

Non-ionic detergents : They do not contain any ion in them. eg : Ester of stearic acid and polyethylene glycol.

OR

Antihistamines are drugs that interfere with the natural action of histamines. eg : (1) Bromopheniramine (2) Terfenadine - They interfere with the natural action of histamine by competing with histamine binding sites of receptor where histamine exerts its effect.

28. (a) $P_A = P_A^0 \times X_A$, X_A - Mole fraction of A

P_A - Partial vapour pressure of A

P_A^0 - Vapour pressure of pure A

According to Dalton's law of partial pressure, total pressure $P = P_A + P_B$ or $P = X_A P_A^0 + X_B P_B^0$

Here for a solution containing non volatile solute

$$P = P_A = X_A P_A^0$$

But for a binary solution, $X_A + X_B = 1$ or $X_A = 1 - X_B$

Hence the above equation becomes $P = 1 - X_B$

where X_B = mole fraction of solute

$$\text{ie, } P = P_A^0 - X_B P_A^0$$

$$X_B P_A^0 = P_A^0 - P \quad \text{or} \quad X_B = \frac{P_A^0 - P}{P_A^0}$$

- (b) $\frac{\Delta P}{P^0} = i X_B$, $i = \frac{1}{2}$

$$X_B = \frac{n_B}{n_A + n_B} = \frac{61/122}{61/122 + \frac{500}{78}} = \frac{0.5}{0.5 + 6.41} = \frac{0.5}{6.91}$$

$$\frac{\Delta P}{66.6} = \frac{1}{2} \times \frac{50}{691}, \quad \Delta P = \frac{50 \times 66.6}{691 \times 2} = 2.41$$

$$P^0 - P = 2.41, \quad P = 66.6 - 2.40 = 64.20 \text{ torr}$$

- (ii) In the absence of dimerisation

$$i = 1; \quad \frac{\Delta P}{P^0} = X_B$$

$$Dp = \frac{50}{691} \times 66.6 = 4.82$$

$$P = 66.6 - 4.82 = 61.78 \text{ torr}$$

- (iii) From Raoult's law

X_1 = mole fraction of liquid 1

X_2 = mole fraction of liquid 2

Chemistry - Sample Question Papers and Answers

$$P_1 = X_1 P_1^0; P_2 = X_2 P_2^0$$

Y_1 = Mole fraction of component - 1 in vapour phase.

Y_2 = Mole fraction of component - 2 in vapour phase.

$$Y_1 = \frac{P_1}{P_{\text{total}}} = \frac{P_1}{P_1 + P_2} \quad Y_2 = \frac{P_2}{P_{\text{total}}} = \frac{P_2}{P_1 + P_2}$$

$$Y_1 = \frac{X_1 P_1^0}{X_1 P_1^0 + X_2 P_2^0} = \frac{X_1 P_1^0}{X_1 P_1^0 + (1 - X_1) P_2^0}$$

$$Y_2 = \frac{X_2 P_2^0}{X_1 P_1^0 + X_2 P_2^0}$$

OR

(a) 1 M has higher concentration than 1m.

1 m solution = 1 mole in 1000 g solvent

or

1 mole in 1000 cm³ of solvent if $d = 1 \text{ g/cm}^3$

But 1 M solution = 1 mole in 1000 cm³ of solution
ie, solvent is less here,

(b) $\Delta T_f = 0 - (-0.24) = +0.24^\circ \text{C}$

$$M_2 = \frac{1000 K_f W_2}{\Delta T_f W_1} = \frac{1000 \times 1.86 \times 5}{0.24 \times 100} \text{ g mol}^{-1} = 38.75 \text{ g mol}^{-1}$$

Theoretical molecular mass of KCl

$$= 39 + 35.5 = 74.5 \text{ g mol}^{-1}$$

$$i = \frac{\text{Calculated mol. mass}}{\text{Theoretical mol. mass}} = \frac{74.5}{38.75} = 1.92$$



Initial moles: 1 mole 0 0

After dissociation: 1 - a a a

Total no. of moles after dissociation

$$= 1 - a + a + a = 1 + a$$

$$i = \frac{1 + \alpha}{1}$$

$$a = i - 1 = 1.92 - 1 = 0.92$$

Percentage dissociation = 92%

29. (a) CuF_2

In CuF_2 , Cu^{2+} ($3d^9$) has an unpaired electron.

(b) (i) Oxidation state of Cr in CrO_4^{2-} is +6. This is its maximum oxidation state and it can only gain electrons. Oxidation state of Mn in MnO_4^{2-} is +6. Mn can further lose electron to become +7 which is its highest oxidation state.

(ii) This is due to lanthanoid contraction.

(iii) In its highest oxidation state, manganese can only accept electrons and so is acidic in behaviour. Similarly in its lowest oxidation state, it can donate electrons and hence is basic.

(iv) Mn (II) has maximum number of unpaired electrons ie. $3d^5$.

OR

(a) Dil. H_2SO_4 is an oxidising agent and oxidises FeSO_4 to $\text{Fe}_2(\text{SO}_4)_3$.

Dil. HCl is a reducing agent and liberates chlorine on reacting with KMnO_4 solution. Thus, part of the oxygen produced from KMnO_4 is used up by HCl.

(b) (i) In oxoanions, the oxygen atoms are directly bonded to the transition metal. Since oxygen is highly electronegative, the oxoanions bring out the highest oxidation state of the metal.

(ii) Ce^{4+} has the tendency to attain +3 oxidation state and so it is used as an oxidising agent in volumetric analysis.

(iii) This is due to the presence of voids of appropriate sizes in their crystal lattices.

(iv) Zn^{2+} ion has all its orbitals completely filled where as in Cu^{2+} ion, there is one half-filled 3d-orbital. It therefore has a tendency to form coloured salts where as Zn^{2+} has no such tendency.

30. (i) A is CH_3CHO or ethanal

B is $\text{C}_6\text{H}_5\text{CHO}$ or benzaldehyde.

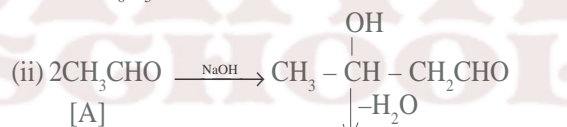

[A]

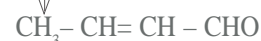

2 -Butenal

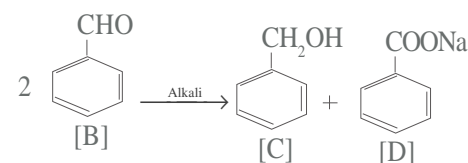

[B]

[C]

[D]

(iii) Toluene

OR

(i) X is CH_3CHO ; Y is CH_3COOH

(ii) 3 - Hydroxybutanal.

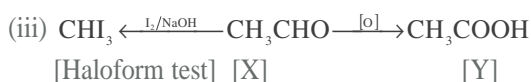

[Haloform test] [X]

[Y]

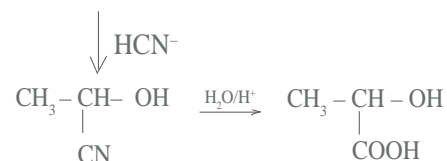

CONTENTS

UNIT NO	UNIT NAME	PAGE NO
1	THE SOLID STATE	3 - 6
2	SOLUTIONS	7 – 11
3	ELECTROCHEMISTRY	12 - 14
4	CHEMICAL KINETICS	15 - 16
5	SURFACE CHEMISTRY	17 - 18
6	GENERAL PRINCIPLES AND PROCESSES OF ISOLATION OF ELEMENTS	19
7	THE p- BLOCK ELEMENTS	20 - 23
8	THE d and f BLOCK ELEMENTS	24 - 27
9	CO-ORDINATION COMPOUNDS	28
10	HALOALKANES AND HALOARENES	29 - 30
11	ALCOHOLS PHENOLS AND ETHERS	31 - 32
12	ALDEHYDES KETONES AND CARBOXYLIC ACIDS	33 - 39
13	AMINES	40
14	BIOMOLECULES	41 - 42
15	POLYMERS	43
16	CHEMISTRY IN EVERYDAY LIFE	44 - 46

UNIT - 1

THE SOLID STATE

1-Mark Questions

- 1) In the normal spinel structure, the oxide ions are arranged in CCP pattern. The Zn^{2+} ions occupy one eighth of the tetrahedral holes and one half of the octahedral voids are occupied by Al^{3+} . Give the formula of the spinel.
- 2) Metallic gold crystallizes in FCC lattice. How many nearest neighbours do each gold atom has?
- 3) When a crystal of NaCl is heated in sodium vapour, it acquires a yellow colour. The yellow colour is due to non stoichiometric defect. Name the defect.
- 4) In the face centered cubic arrangement of A and B atoms where A atoms are at the corner of the unit cell and B atoms at the face centres. One of the A atom is missing from one corner in the unit cell. What is the simplest formula of the compound?
- 5) For the structure given below identify the site marked as S.

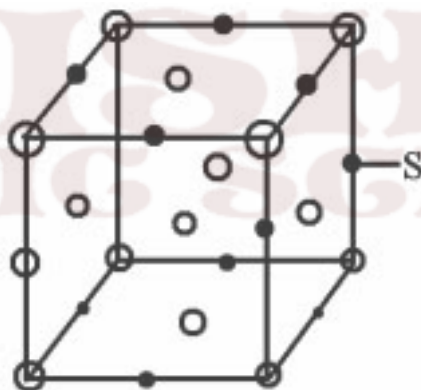

- 6) In BCC lattice, what are the numbers of the nearest and next nearest neighbours?
- 7) What type of magnetism is shown by the substance whose magnetic moments are aligned as given below:



- 8) A solid 'X' conducts electricity in solid state as well as in molten state. Its conductance decreases with increase in temperature. Identify the solid X.
- 9) In Chromium(III) Chloride, $CrCl_3$, chloride ions have cubic close packed arrangement and Cr(III) ions are present in the octahedral holes. What is the fraction of octahedral holes occupied? What is the fraction of total number of holes occupied?

2 Marks Questions

- 10) A compound AB crystallizes in BCC lattice with unit cell edge length of 480Pm. If the radius of B is 225Pm. Calculate the radius of A⁺.
Hint:

$$\text{For BCC structure: } 2(r_A+r_B) = \sqrt{3} a$$

- 11) In the close packing arrangement of atoms does a face centred atom touch the face centred atom of an adjacent face? Give reason for your answer.
- 12) Identify the crystal systems which have the following crystallographic dimensions:

$$a \neq b \neq c \quad \alpha = \beta = \gamma = 90^\circ$$

$$a = b \neq c \quad \alpha = \beta = 90^\circ \quad \gamma = 120^\circ$$

- 13) Identify the unit cell and calculate the number of atoms per unit cell.

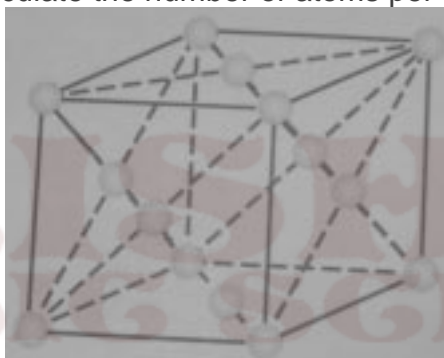

- 14)

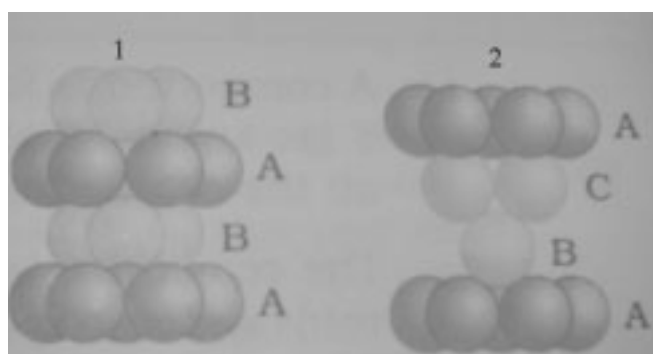

- a. What are the types of close packing shown in figure 1 and 2?
- b. Write one example for each type of close packing in metals.

- 15) The composition of a sample of wustite is $\text{Fe}_{0.93}\text{O}_{1.00}$. What percentage of Fe is present as Fe(III)?
- 16) Iron changes its crystal structure from body centred to cubic close packed structure when heated to 916°C . Calculate the ratio of the density of the BCC crystal to that of CCP crystal. Assume that the metallic radius of the atom does not change.
Hint:
Volume same, so ratio of density is also same
i.e. $d(\text{bcc})/d(\text{ccp})$
- 17) A compound forms hexagonal close packed structure. What is the total number of voids in 0.5 mol of it? How many of these are tetrahedral voids?
- 18) The electrical conductivity of Zinc oxide increases on heating. Give reason.
- 19) Both the ionic solids NaF and MgO have the same number of electrons and about the same inter nuclear distances. But the melting point of NaF is 992°C and that of MgO is 2642°C . Give plausible reason for this observation.
Hint:- charge of ions and lattice enthalpy.
- 20) The concentration of cation vacancies in NaCl crystal doped with CdCl_2 is found to be $6.02 \times 10^{16} \text{ mol}^{-1}$. What is the concentration of CdCl_2 added to it?

3 Marks Questions

- 21) Calcium crystallizes in a face centred cubic unit cell with $a=0.556\text{nm}$. Calculate the density if
- It contains 0.1% Frenkel defects.
 - It contains 0.1% Schottky defects.

Hint:

Frenkel defect does not affect density.

$$d = zM/a^3N_A$$

Schottky defect reduces the density by 0.1%, assuming that volume remains constant.

$$d' = d(1 - 0.1/100)$$

$$d' = 0.999d$$

- 22) You are given marbles of diameter 10mm. They are to be placed such that their centres are lying in a square bound by four lines each of length 40mm. What will be the arrangements of the marbles in a plane so that maximum number of marbles can be placed inside the area? Sketch the diagram and calculate the number of spheres per unit area.

23)

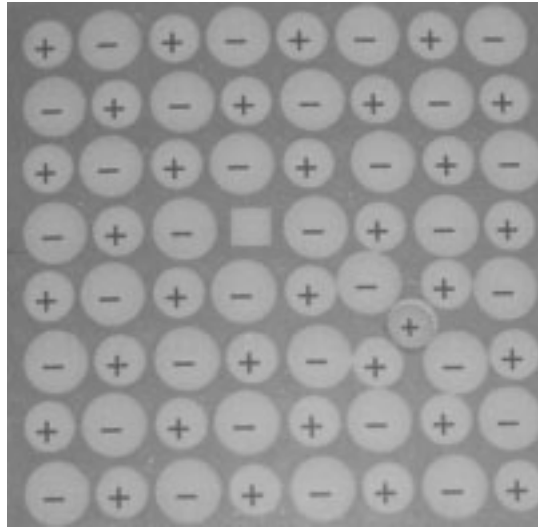

- i. Name the defect shown in the figure.
 - ii. How does it affect the density of the solid?
 - iii. Name a solid which shows this defect.
- 24) In the mineral, spinel, having the formula $MgAl_2O_4$, oxide ions are arranged in the cubic close packing. Mg^{2+} ions occupy the tetrahedral voids while Al^{3+} ions occupy the octahedral voids.
- (i) What is the percentage of tetrahedral voids occupied by Mg^{2+} ions?
 - (ii) What is the percentage of octahedral voids occupied by Al^{3+} ions?
- 25) Metallic magnesium has a hexagonal close packed structure and has a density 1.74 g cm^{-3} . Assuming magnesium atoms to be spherical, calculate the radius of magnesium atom. (Atomic mass of Magnesium = 24.3).
- Hints: Consider 1 cm^3 Mg and calculate mass of 1 cm^3 of Mg. Then calculate the No: of atoms in that much mass of Mg. Calculate the volume occupied by the Mg Atoms and that occupied by 1 Mg atom. Then using the formula $\frac{4}{3} \pi r^3$ radius of Mg, r can be calculated

UNIT - 2

SOLUTIONS

1 Marks Questions

1. A 500 gm of toothpaste sample has 0.2 g of fluoride concentration. What is the concentration of fluoride in terms of ppm level?
2. Two liquids A and B boil at 135°C and 185°C respectively. Which of them has a higher vapour pressure at 80°C ?
3. Write the possible structural arrangement of a mixture of chloroform and acetone to form a solution.
4. What is Van't Hoff's factor for a compound which undergoes tetramerization in an organic solvent?
5. Aquatic species are more comfortable in cold waters rather than in warm water. Give reason.

2 marks questions

6. RBC's are placed in the given solutions as in figure (i) and (ii). What happens to RBC in test tube (i) and test tube (ii).

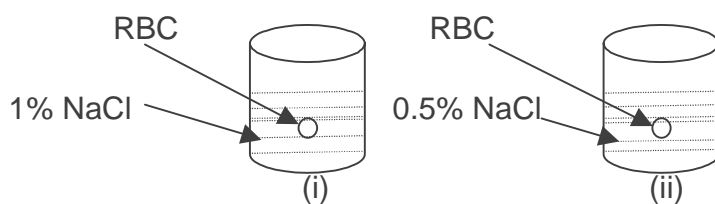

7. Given below is the sketch of a plant carrying out a process.

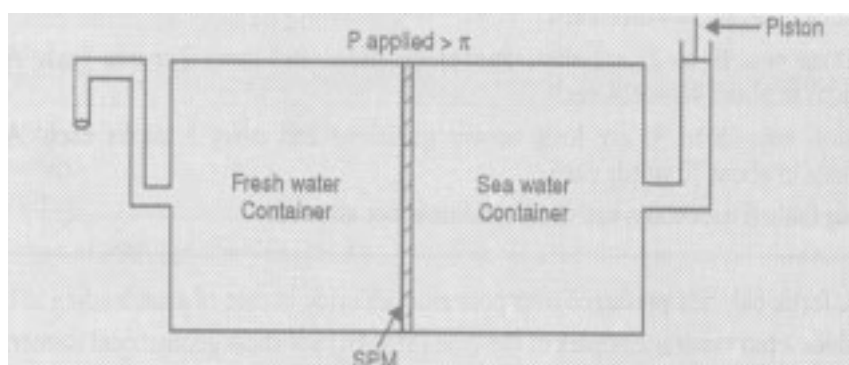

- (i) Name the process occurring in the above plant.
- (ii) To which container does the net flow of the solvent takes place?
- (iii) Name one SPM which can be used in this plant.
- (iv) Give one practical use of the plant.

8. A solution of sucrose (Molar mass 342 g mol^{-1}) is prepared by dissolving 68.4 g in 1000 g of water. What is the

- (i) Vapour pressure of the solution at 293k .
- (ii) Osmotic pressure at 293k .
- (iii) Boiling point of the solution.
- (iv) Freezing point of the solution.

The vapour pressure of the water at 293k is 0.023atm . $k_b=0.52\text{k kg mol}^{-1}$ & $k_f=1.86\text{k kg mol}^{-1}$. Assume the solution to behave ideally.

9. Why calculations based on colligative properties of solutions sometimes do gives abnormal molecular mass values for solute? What are the nature of the abnormalities. 2g of $\text{C}_6\text{H}_5\text{COOH}$ dissolved in 25g of benzene shows a depression in freezing point equal to 1.62k . Molal depression constant for benzene is 4.9k kg mol^{-1} . What is the Percentage(%) of association of acid, if it forms a dimer in solution?
10. Assuming complete dissociation, calculate the freezing point of a solution prepared by dissolving 6 g of glaubers salt ($\text{Na}_2\text{SO}_4 \cdot 10\text{H}_2\text{O}$) in 0.100 kg of H_2O . Given $k_f = 1.86\text{k kg mol}^{-1}$ Atomic mass of $\text{H}_2\text{O} : 18$, $\text{Na} : 23$, $\text{S} : 32$, $\text{O} : 16$, $\text{H} : 1$ all in amu units.

3 Marks Questions

11. A) Addition of Hgl_2 to aq. KI solution shows an increase in the vapour pressure why?
- B) A person suffering from high blood pressure is advised to take minimum quantity of common salt. Give reason.

12. A) Why the vapour pressure of a solution of glucose in water lower than that of water?
- B) 0.1 molal solution of glucose and NaCl respectively. Which one will have higher boiling point?
13. H_2S , a toxic gas with rotten egg like smell is used for qualitative analysis. If the solubility of H_2S in water at STP is 0.195 m, calculate Henry's law constant ($k_H=282 \text{ bar}$)
14. Examine the following illustrations and answer the following questions

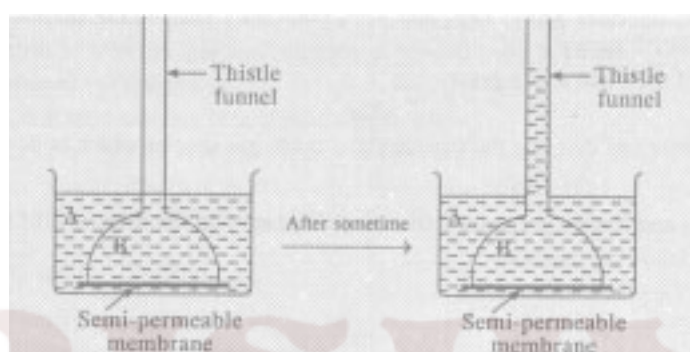

- 1) Identify the liquid A (pure water or sugar solution).
 - 2) Identify the liquid B (pure water or sugar solution).
 - 3) Why the level of liquid in thistle funnel has risen after sometime?
 - 4) Name the phenomenon involved in this experiment and define it.
15. A storage battery contains a solution of H_2SO_4 38% by weight. At this concentration van't Hoff factor is 2.50. At what temperature will the battery contents freeze?
- (k_f for water = 1.86 k kg/ mol)
16. Following are the graphs for the vapour pressure of two component system as a function of composition. Answer the following questions.

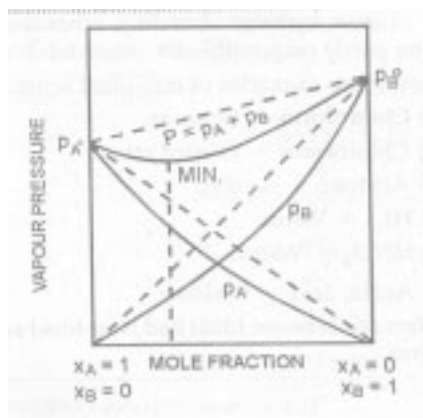

Fig (a)

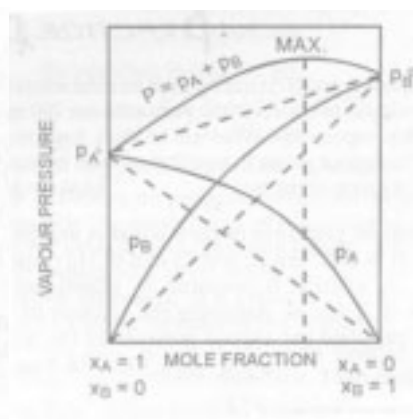

Fig. (b)

- (i) What type of deviation is shown in fig.(a) and (b)?
- (ii) Give one example of solutions showing deviations in fig (a) (b).
- (iii) What change in the volume and temperature is observed in solutions of this type?

17. How does osmotic pressure depend on temperature and atmospheric pressure, what is the molar concentration of solute particles in the human blood, if the osmotic pressure is 7.2 atm at the body temperature of 37°C?

18. The vapour pressure of dilute aqueous solution of glucose ($C_6H_{12}O_6$) is 750 mm of mercury at 373K. Calculate

- 1) Molality
- 2) Mole fraction of the solute

5 Marks Questions

19. The elements A and B form purely covalent compounds having molecular formulae AB_2 and AB_4 . When dissolved in 20g of benzene, 1g of AB_2 lowers the freezing point by 2.3K, whereas 1g of AB_4 lowers it by 1.3K. the molal depression constant for benzene is 5.1 K kg/mol, calculate the atomic mass of A and atomic mass of B. **(A=25.59, B=42.64)**
20. a) Why constant boiling mixtures behave like a single component when subjected to distillation.

b) What type of Azeotropic mixtures are formed by the following solution

i) H_2O and HCl ii) H_2O and $\text{C}_2\text{H}_5\text{OH}$

c) Give one practical application of depression of freezing point?

d) A Solid solution is formed between two substances. One whose particles are very large and the other particles are very small. What type of solid solution is this likely to be?

e) Write the Raoult's Law for each component of a binary solution and show that the total vapour pressure of the solution may be expressed as $P = P^0_A + (P^0_B - P^0_A) X_B$

21. Vapour pressure of pure benzene at a certain temperature is 640 mm Hg. A non-volatile non-electrolyte solid weighing 2.175g is added to 39.0 of benzene. The vapour pressure of solution is 600 mm Hg. What is the molecular mass of solid substance? (**65.9g mol⁻¹**)

22. The degree of dissociation of $\text{Ca}(\text{NO}_3)_2$ in dilute solution aqueous solution containing 7.0g of the solute per 100g of water at 100° C is 70 percent. If the vapour pressure of water at 100° C is 760mm, calculate the vapour pressure of the solution. (**746.02mm**)

23. What mass of a non-volatile solute urea (NH_2CONH_2) need to be dissolved in 100g of water in order to decrease the vapour pressure of water by 25%? also calculate the molality of the solution. (**18.52m**)

24. 8.0575×10^{-2} kg of Glauber's salt is dissolved in water to obtain 1 dm³ of a solution of density 1077.2 kg m⁻³. Calculate the molarity, molality & mole fraction of Na_2SO_4 in the solution. (**0.2508m, 0.0045, 0.25M**)

25. To 500 cm³ of water 3.0 X 10⁻³ kg of acetic acid is added. If 23% of acetic acid is dissociated, what will be the depression in freezing point? K_f and density of water are 1.86 K kg mol⁻¹ & 0.997 g cm⁻³ respectively. (**0.229K**)

UNIT - 3

ELECTROCHEMISTRY

2 Marks Questions

- 1 How many faraday of charge is required for conversion of $C_6H_5NO_2$ into $C_6H_5NH_2$?
- 2 Explain why Zn dissolves in dil. HCl to liberate $H_2(g)$ but from conc. H_2SO_4 , the gas evolved is SO_2 .
- 3 Cu does not dissolve in HCl but dissolves in nitric acid. Explain why?
- 4 Fluorine has a low electron gain enthalpy compared to chlorine, yet it is a more powerful oxidant. Explain why?
- 5 If Zn^{2+}/Zn electrode is diluted 100 times, then what will be the change in emf?
- 6 You are acquainted with the construction and working of a lead-storage battery. Give the plausible reasons for these facts:
 1. There is only a single compartment unlike other electrochemical cells.
 2. Replacement of water is necessary for maintenance.
- 7 For what concentration of $Ag^+(aq.)$, will the emf of given cell be zero at $25^\circ C$, if the concentration of $Cu(s) | Cu^{2+}(0.1M) || Ag^+(aq.) | Ag(s)$?
Given, $E^0_{Ag^+/Ag} = 0.80V$; $E^0_{Cu^{2+}/Cu} = 0.34V$.
- 8 In a small town along the costal area, it is observed that iron objects rust easily. Being an industrial town, it also faces air pollution problem. Identify any 4 factors which are contributing to rusting phenomenon.
- 9 Iodine(I_2) and Bromine(Br_2) are added to a solution containing iodide(I^-) and bromide ions(Br^-). What reaction would occur if the concentration of each species is 1M? The electrode potentials are $E^0_{I_2/I^-} = 0.54V$ and $E^0_{Br_2/Br^-} = 1.08V$

3 Marks Questions

- 10 In an industrial plant, aluminium is produced by electrolysis of alumina dissolved in cryolite. This takes a current of 20000A. If the current efficiency is 90%, how much Al will be produced per day?
→
- 11 In an experiment 0.04 F was passed through 400 mL of 1M soln. of NaCl. What would be pH of the soln. after electrolysis.
- 12 Estimate the minimum P.D. needed to reduce Al_2O_3 at 500 °C. The free energy change for the decomposition reaction is 960 kJ.
 $2/3 \text{Al}_2\text{O}_3 \rightarrow 4/3 \text{Al} + \text{O}_2$; $\Delta G = 960 \text{ kJ}$
13. A cell with N/50 KCl soln. offered a resistance of 550 ohms at 298 K. The specific conductance of N/50 KCl at 298 K is $0.002768 \text{ ohm}^{-1}\text{cm}^{-1}$. When the cell is filled with N/10 ZnSO_4 soln, it offered a resistance of 72.18 ohms at 298 K. Find the cell constant and molar conductance of ZnSO_4 soln. at 298K.
14. Which of the following has larger molar conductance:
a. 0.08 M soln. having conductivity equal to $2 \times 10^{-2} \text{ ohm}^{-1}\text{cm}^{-1}$.
b. 0.10 M soln. having resistivity equal to 5.8 ohm cm.
15. The K_{sp} of AgCl at 298 K is 1×10^{-10} . Calculate electrode potential of Ag electrode immersed in 1 M KCl soln..
[Given: $E^0 \text{Ag}^+/\text{Ag} = 0.799 \text{ V}$]
16. Tarnished silver contains Ag_2S . Can this tarnish be removed by immersing the tarnished silverware in an Al pan containing an inert electrolyte soln. such as NaCl?
Given that standard electrode potentials for half reactions are:
 $\text{Ag}_2\text{S}(\text{s}) + 2\text{e}^- \rightarrow 2\text{Ag}(\text{s}) + \text{S}^{2-}(\text{aq.})$ is -0.71 V
 $\text{Al}^{3+}(\text{aq.}) + 3\text{e}^- \rightarrow \text{Al}(\text{s})$ is -1.66 V.

5 Marks Questions

- 17 Observe the diagram carefully and answer the questions below:

An external opposite potential is applied such that it exceeds the cell potential.

- Is this an electrochemical cell or electrolytic cell?
- Which substance gets dissolved?
- Which substance gets deposited and where?
- Write half cell reactions.
- Is the needle in the voltmeter correctly marked?

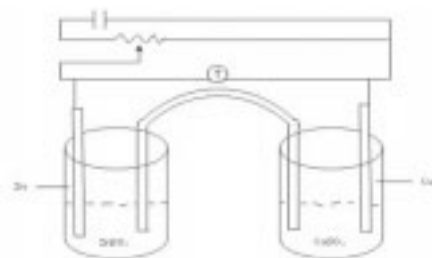

- 18 2 beakers A and B contain 1 M ZnSO_4 solution. To A, Strip of Mg is dipped, while in B, A zinc rod is put. If both are connected to a standard hydrogen electrode, which cell would show a deflection? Explain with suitable reason.

- 19 The standard electrode potentials of different electrodes are given as

$$E^{\circ}_{\text{Co}^{3+}/\text{Co}^{2+}} = 1.81 \text{ V}, \quad E^{\circ}_{\text{Al}^{3+}/\text{Al}} = -1.66 \text{ V}, \quad E^{\circ}_{\text{Fe}^{2+}/\text{Fe}} = -0.44 \text{ V}, \\ E^{\circ}_{\text{Br}_2/\text{Br}^-} = 1.01 \text{ V}$$

- Identify all the possible combination for construction of a feasible electrochemical cell?
 - Write their electrochemical cell representation.
 - Calculate the emf in each case.
- 20
- During electrolysis of NaOH, Cl_2 and H_2 while for molten NaCl only Na metal and Cl_2 gas are obtained. Explain these observations with suitable eqn.
 - Electrolysis of conc. and dil. sulphuric acid are different. Explain with eqn.
- 21 An Aq. solution of AuCl_3 was electrolysed with a current of 0.5A until 1.20g of Au had been deposited on the cathode. At another electrode in series with this, the only reaction was evolution of O_2 . Find—
- The no. of moles
 - The volume at NTP
 - The mass of O_2 liberated
 - the no. of coulombs passed through the solution and
 - the duration of electrolysis

UNIT – 4

CHEMICAL KINETICS

1 Mark Questions

1. If rate law is; rate = $[A]^{3/2} [B]^{-1}$, determine the order.
2. A gas decomposition of AB follows the rate law; rate = $K[AB]^{3/4}$. Write units of K.
3. State any one condition under which a bimolecular reaction may be kinetically of first order.
4. In some cases, it is found that a large number of colliding molecules have energy more than threshold energy, yet the reaction is slow. Why?
5. Variation of concentration of a reactant with time for a given reaction is shown below. What is its order of reaction?

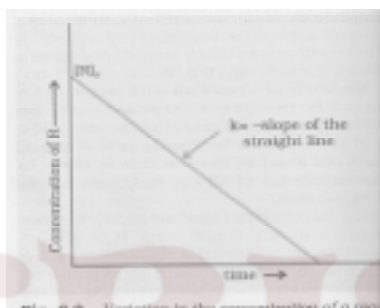

6. Variation of concentration of a reactant, $\ln[R]$ with time for a given reaction is shown below. What is its order of reaction?

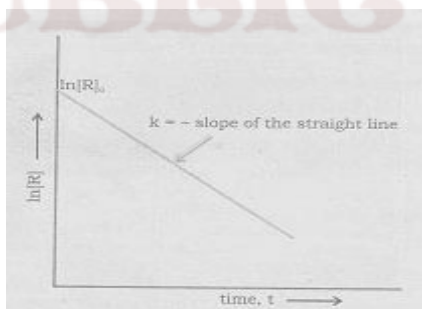

2 / 3 Mark Questions

7. The kinetics of the reaction: $A + 2B \rightarrow \text{Products}$; obeys the rate equation $\text{Rate} = k [A]^x [B]^y$. For it, find
 - a) Order of the reaction
 - b) Apparent molecularity of reaction
 - c) Order of reaction when B is in large excess.
8. Following reaction takes place in one step

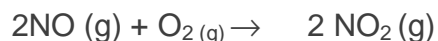

How will the rate of above reaction change if the volume of the reaction vessel is diminished to one third of its original volume? Will there be any change in order of reaction with the reduced volume?

9. For the reaction

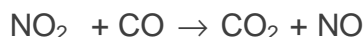

Mechanism of reaction is

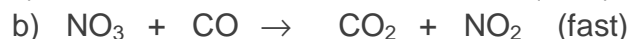
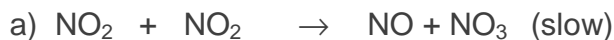

Write its rate law.

10. The activation energy of a first order reaction is 30 kJ/mol at 298K. The activation energy for the same reaction in the presence of a catalyst is 24 kJ/mol at 298K. How many times the reaction rate has changed in the presence of a catalyst?
11. A reaction is carried out at two different initial concentrations of a reactant. The initial concentrations are 1 mol L^{-1} and 2 mol L^{-1} . The half-life values obtained were 20 minutes and 40 minutes respectively. What is the order of reaction?
12. In the Arrhenius equation for a certain reaction, the value of A and E_a are $4 \times 10^{13} \text{ s}^{-1}$ and 98.6 kJ mol^{-1} respectively. If the reaction is of first order; at what temperature will its half life period be ten minutes?
13. The time required for 10% completion of a first order reaction at 298 K is equal to that required for its 25% completion at 308K. If the pre-exponential factor for the reaction is $3.56 \times 10^9 \text{ sec}^{-1}$, calculate its rate constants at 318K and also the energy of activation.

5 Mark Questions

14. Following is a graph between reaction co-ordinate and potential energy. Explain how a catalyst influence the reaction.

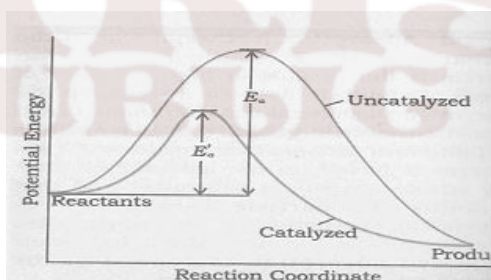

15. In a given graph, if 'E' is the activation energy for a given reaction, explain how temperature influences the rate of reaction.



16. In the following figure, orientations of reaction molecules are shown. Explain the influence of orientation of molecules in a chemical reaction?

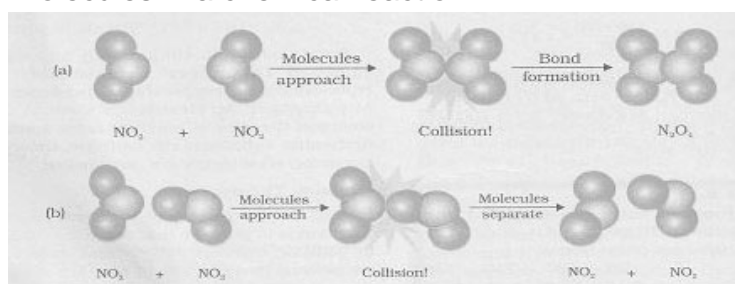

UNIT-5

SURFACE CHEMISTRY

2 Marks Questions

- 1 Explain how activated charcoal adsorbs organic dye.
2. A graph between $\log(x/m)$ and $\log p$ is a straight line at angle of 45° with intercept on the y-axis ($\log k$) equal to 0.301. Calculate the amount of the gas adsorbed per gram of the adsorbent under a pressure of 0.4 Atmosphere

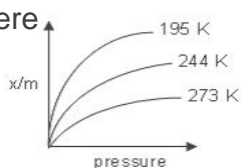

- 3 Adsorption is always exothermic in nature. Comment.
- 4 Critical temperatures of N_2 , CO , CH_4 are 126, 134, and 110 K respectively. Arrange them in increasing order of adsorption on the surface of activated charcoal?
- 5 Consider the adsorption isotherms given below and interpret the variation in the extent of adsorption (x/m) when:
 - (i) Temperature increases at constant pressure.
 - (ii) Pressure increases at constant temperature
- 6 If the flocculation values of $NaCl$ and $AlCl_3$ are respectively 52 and 0.093, compare their coagulating powers.
7. Explain how soap solution stabilizes an emulsion of oil in water?
- 8 What happens when a freshly precipitated $Fe(OH)_3$ is shaken with little dil. $FeCl_3$ solution? Explain with possible reactions.
- 9 A methanol poisoned patient is treated by giving intravenous infusion of dil. ethanol. Explain.
[Hint: Influence of inhibitors]
- 10 How does a 'collector' separate the ore from gangue in the froth floatation process?

KAROLINA
PUBLIC SCHOOL

3 Marks Questions

- 11 A colloidal solution of AgI is prepared by 2 different methods as shown:

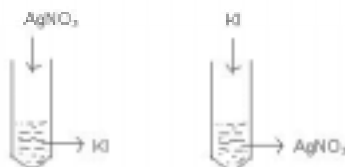

- (i) What is the charge of AgI colloidal particles in the two test tubes (A) and (B)?
- (ii) Give reasons for the origin of charge.
- 12 SnO_2 forms a positively charged colloidal sol in the acidic medium and negatively charged sol in basic medium. Explain.
- 13 1 g of charcoal adsorbs 100 ml of 0.5 M CH_3COOH to form a monolayer and thereby the molarity of acetic acid is reduced to 0.49 M. Calculate the surface area of the charcoal adsorbed by each molecule of acetic acid. Surface area of charcoal = $3.01 \times 10^2 \text{ m}^2/\text{g}$.
- 14 To 100 ml of M/2 oxalic acid solution 2 g of active charcoal is added. After adsorption the strength of solution is reduced to M/4. Calculate the acid adsorbed by 1 g of charcoal.
- 15 Explain why:
- (i) At sunset an orange colour develops in the sky.
- (ii) Bleeding due to a small cut can be stopped by rubbing alum.
- Activated charcoal is used in gas masks used by coal miners.

UNIT - 6

GENERAL PRINCIPLES AND PROCESS OF ISOLATION OF ELEMENTS

1 Mark questions

1. During metallurgical process, in the extraction of metal, flux is added. Why?
2. 'Reduction of a metal oxide is easier if the metal formed is in liquid state at the temperature of reduction. Why?
3. Although thermodynamically feasible, in practice, magnesium metal is not used for the reduction of alumina in the metallurgy of aluminium. Why?
4. Can Mg reduce Al_2O_3 and Al reduces MgO? State the conditions required for this reduction process.

2/3 Marks Questions

5. At a site, low grade copper ores are available and zinc and iron scraps are also available. Which of the two scraps would be more suitable for reducing the leached copper ore and why?
6. The value of $\Delta_f G^\circ$ for formation of Cr_2O_3 is -540 kJ mol^{-1} and that of Al_2O_3 is -827 kJ mol^{-1} . Is the reduction of Cr_2O_3 possible with Al?
7. Why is zinc not extracted from zinc oxide through reduction using CO?
8. Cinnabar (HgS) and Galena (PbS) on roasting often give their respective metals but Zinc blende (ZnS) does not. Why?
9. The choice of a reducing agent in a particular case depends upon thermodynamic factor. How far do you agree with this statement? Explain?
10. "The extraction of Ag by leaching with NaCN involves both oxidation and reduction". Explain?
11. Out of C and CO which is a better reducing agent at 673 K?

UNIT-7

p- BLOCK ELEMENTS

1 Mark Questions

1. Which amongst the following is the strongest oxidizing agent?



2. A student wanted to draw his school building on a glass sheet, which acid he should use?

3. Nitrogen and P give negative ions, while As, Sb and Bi do not. Why?

4. Sea weeds are the sources of which halogen?

5. When NaBr is heated with conc H_2SO_4 , Br_2 is produced but when NaCl is heated with conc H_2SO_4 , HCl is produced. Why?

6. Which oxo-acid of Phosphorus contains P-P linkage?

7. Out of HClO_3 and HClO_4 , which has lower Pka value and why?

8. Name the acidic hydride of N_2 ?

9. State the difference between the nature of Pi bonds in H_3PO_3 and HNO_3 molecules?

10. Name the gas liberated when Ammonium Nitrate is strongly heated.

11. Give one disproportionation reaction of H_3PO_3 .

2 Mark Questions

12. Oxides of Nitrogen have open chain structure, while those of Phosphorous have closed chain or cage structures. Why is it so?

13. Complete the following :

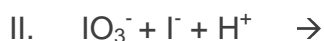
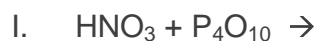

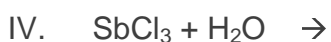
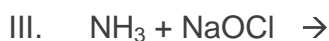

14. Calculate the amount of 0.1 M NaOH solution required to neutralize the solution produced by dissolving 1.1 g of P_4O_6 in water.
15. Explain giving reason. Nitrogen exists as a diatomic molecule whereas Phosphorous exists as tetra atomic molecule.
16. Name the hydrogen halide which is liquid at room temperature and why?
17. Which oxide of sulphur is capable of acting as oxidizing as well as reducing agent? Why?
18. $(\text{SiH}_3)_3\text{N}$ is a weaker base than $(\text{CH}_3)_3\text{N}$. Give reason.
19. CN^- ion is known but CP^- not known. Give reason.
20. Explain giving reason. NF_3 is an exothermic compound but NCl_3 is an endothermic compound.
21. Which halogen will produce O_2 and O_3 as passed through water?
22. Nitrogen forms a large no. of oxides than Phosphorous. Explain.

3 marks question

23. Account for the following
- Chlorine water has both oxidizing and bleaching properties.
 - H_3PO_2 and H_3PO_3 act as good reducing agents while H_3PO_4 doesn't.
24. An organic compound A gives a brick red flame on performing flame test. The compound gives the following tests also
- It gives smell of chlorine when placed in moist air.
 - If KI and CH_3COOH are added to the solution of the compound a violet colour is observed.
- Identify the compound and write the chemical reactions for the steps (I) and (II).

25. Give reasons for each of the following observations

- I. Only higher members of the group 18 of the periodic table are expected to form compounds.
- II. NO_2 readily forms a dimer whereas ClO_2 doesn't.

26. Give reasons for the following observations

- I. SF_6 is used as gaseous electrical insulators.
- II. S exhibit greater tendency for catenation than selenium.
- III. The electron gain enthalpy value of F_2 is less negative than chlorine.

27. Bleaching of flowers by Cl_2 is permanent, by SO_2 it is temporary. Explain?

28. Hydrogen halides are covalent compounds but their aqueous solutions can conduct electric current. Explain.

29. Which of the halogens (except At)

- I. Forms the weakest acid?
- II. Has the largest atom?
- III. Has the minimum ionization enthalpy?
- IV. Has the maximum electron affinity?

30. Knowing the electron gain enthalpy values for $\text{O} \rightarrow \text{O}^-$ and $\text{O} \rightarrow \text{O}^{2-}$ as

-141 KJ/mol and 702 KJ/mol respectively, how can you account for the formation of a large no. of oxides having O^{2-} species and not O^- (clue: Lattice Enthalpy).

31. What happens when SO_2 is passed through an aq. Solution of Fe (III) salt. Give equation.

5 Marks Question

32. An element 'A' exists as a yellow solid in standard state. It forms a volatile hydride 'B' which is a foul smelling gas and is extensively used in qualitative analysis of salts.

When treated with oxygen, 'B' forms an oxide 'C' which is colourless, pungent smelling gas. This gas when passed through acidified KMnO_4 solution, decolourizes it. 'C' gets oxidized to another oxide 'D' in the presence of a Heterogeneous catalyst. Identify A, B, C, D and also give the chemical equation of reaction of 'C' with acidified KMnO_4 solution and for conversion of 'C' to 'D'.

33. Concentrated sulphuric acid is added followed by heating to each of the following test tubes labelled (i) to (v)

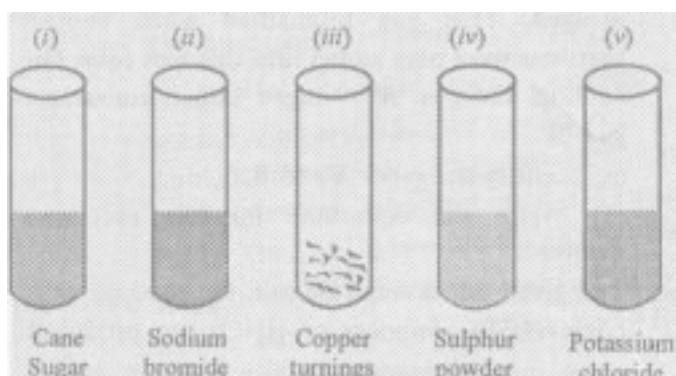

Identify in which of the above test tube the following change will be observed. Support your answer with the help of a chemical equation.

- (a) Formation of black substance
- (b) Evolution of brown gas
- (c) Evolution of colourless gas
- (d) Formation of brown substance which on dilution becomes blue
- (e) Disappearance of yellow powder along with evolution of colourless gas.

34. When conc. sulphuric acid was added to an unknown salt present in a test tube, a brown gas (A) was evolved. This gas intensified when copper turnings were also added into this tube. On cooling, the gas 'A' changed into a colourless gas 'B'.

- (a) Identify the gases A and B.
- (b) Write the equations for the reactions involved.

35. A translucent white waxy solid 'A' on heating in an inert atmosphere is converted into its allotropic form (B). Allotrope 'A' on reaction with very dilute aqueous KOH liberates a highly poisonous gas 'C' having rotten fish smell. With excess of chlorine 'A' forms 'D' which hydrolyses to compound 'E'. Identify compounds 'A' to 'E'.
36. A colourless inorganic salt (A) decomposes completely at about 25°C to give only two products, (B) and (C), leaving no residue. The oxide (C) is a liquid at room temperature and neutral to moist litmus paper while the gas (B) is a neutral oxide. White phosphorus burns in excess of (B) to produce a strong white dehydrating agent. Write balanced equations for the reactions involved in the above process.

Gradual addition of KI to $\text{Bi}(\text{NO}_3)_3$ solution initially produces a dark brown precipitate which dissolves in excess of KI to give a clear yellow solution. Write chemical equations for the a

KRISHNA
PUBLIC SCHOOL

UNIT - 8
THE d- and f- BLOCK ELEMENTS

1 Mark Questions

1. Ce^{4+} has a noble gas electronic configuration, but it is used as an oxidizing agent in volumetric analysis. Give reason.
2. State why Fluorine stabilizes higher oxidation states?
3. CrO_4^{2-} is a strong oxidizing agent while MnO_4^{2-} is not. Why?
4. Why is Cu_2Cl_2 colourless and CuCl_2 coloured?
5. Which is stronger base $\text{La}(\text{OH})_3$ or $\text{Lu}(\text{OH})_3$? Why?
6. It is found that Ce^{4+} is a good oxidizing agent whereas Sm^{2+} is a good reducing agent. State the reason for this difference.
7. Actinoid contraction is greater from element to element than lanthanoid contraction. Why?
8. Mn^{2+} is more stable than Mn^{3+} . Give the reason?
9. Observe the following equation and identify the phenomenon that takes place:
$$3\text{MnO}_4^{2-} + 4\text{H}^+ \longrightarrow 2\text{MnO}_4^- + \text{MnO}_2 + 2\text{H}_2\text{O}$$
10. $\text{Cr}_2\text{O}_7^{2-} \rightleftharpoons 2\text{CrO}_4^{2-}$
How does this equilibrium can be shifted to right?

2 Marks Questions

11. An yellow translucent solution is obtained on passing H_2S gas through an acidified solution of KMnO_4 . Identify the solution and write the balanced chemical equation.
12. Electronic configuration of $\text{Cu}(\text{I})$ is $[\text{Xe}]3d^{10}$ and that of $\text{Cu}(\text{II})$ is $[\text{Xe}]3d^9$. Which is more stable in aqueous solution? Why?
13. Electronic configuration of four metals A, B and C are give below:

A: $1s^2 \ 2s^2 \ 2p^6 \ 3s^2 \ 3p^6 \ 4s^1 \ 3d^{10}$
B: $1s^2 \ 2s^2 \ 2p^6 \ 3s^2 \ 3p^6 \ 4s^2 \ 3d^{10}$
C: $1s^2 \ 2s^2 \ 2p^6 \ 3s^2 \ 3p^6 \ 4s^2 \ 3d^5$

Identify the transition metals among them.
14. Zr (4d series) and Hf (5d series) have similar radii and have similar physical and chemical properties. Explain why?

15. In a given series the difference in the ionization enthalpies between any two successive d block elements is very much less than that in case of s and p block elements. Give the explanation.

16. Cu^+ is unstable in aqueous solution and disproportionate as



Why does Cu^+ disproportionate in aqueous solution?

17. Observe the following reaction:



(i) Identify the role of Fe^{3+} in this reaction

(ii) Which property of Fe is used up here.

18. Among the oxides of Chromium CrO_3 is acidic, Cr_2O_3 is amphoteric and CrO is basic. State reasons for these observations.

19. For the first row of transition metals the E^\ominus values are

Elements	V	Cr	Mn	Fe	Co	Ni	Cu
$E^\ominus(\text{M}^{2+}/\text{M})$ in volts	-1.18	-0.91	-1.18	-0.44	-0.28	-0.25	+0.34

Observe the values and write the reasons for irregularities.

20. Give reasons for the following:

(i) Mn^{2+} is more stable than Mn^{3+}

(ii) The colour of CuCr_2O_7 in water is green.

3 Marks Questions

21. The structure of chromate ion and dichromate ion are given below;

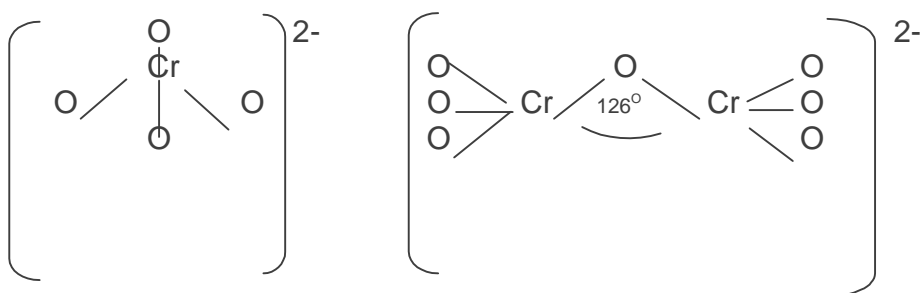

They are interconvertible in aqueous solution depending upon P^{H} of the solution. Give the possible reason for this phenomenon along with the balanced chemical equations.

22. When an orange coloured crystalline compound 'A' was heated with common salt and concentrated H_2SO_4 , an orange red coloured gas 'B' was evolved. The gas 'B' on passing through NaOH solution gave a yellow solution C

- (i) Identify A, B and C.
- (ii) Write balanced chemical equation involved in the reactions.

23. Observe the following graph and answer the questions given below:

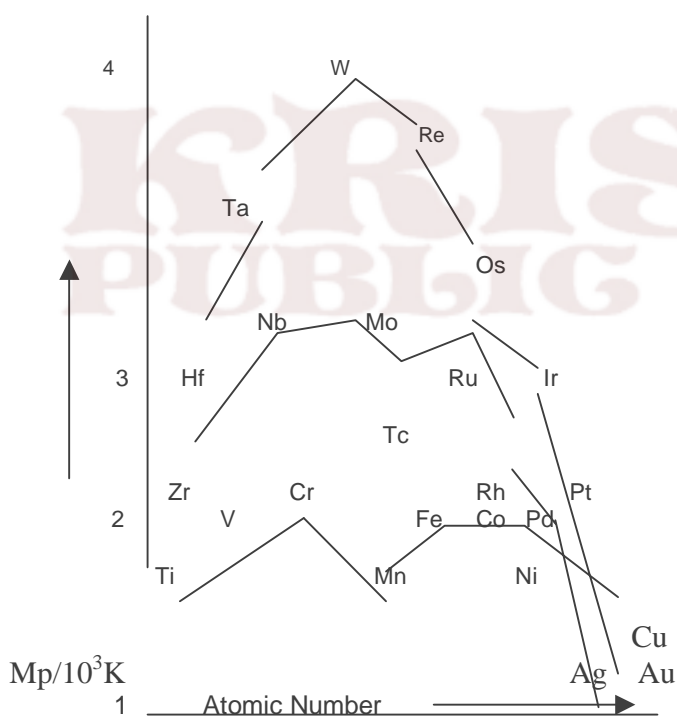

- (i) Why melting point of transition elements generally increases towards middle in each series.
- (ii) Why Mn and Tc in 3d and 4d series respectively have low values of melting points.

(Hint: d^5 – stable electronic configuration; electrons held tightly by nucleus; delocalization is less and metallic bond is weak)

(iii) Why the last members of each series show low values of melting points?

24. Elements	Sc	Ti	V	Cr	Mn	Fe	Co	Ni	Cu	Zn
$\Delta_f H^\ominus_{II}$	1235	1309	1414	1592	1509	1561	1644	1752	1988	1734
$\Delta_f H^\ominus_{III}$	2393	2657	2833	2990	3266	2962	3243	3462	3556	3829

Observe the table and give plausible reasons for the following trends:

- The second ionization enthalpy values of Cr and Cu are unusually high.
- The second ionization enthalpy of Zn is comparatively low.
- The third ionization enthalpy of Mn and Zn are unusually high.

25. Observe the following table and explain the statements given below:

Elements	Ti	V	Cr	Mn	Fe	Co
$E^\ominus(M^{3+}/M^{2+})$ in volts	-0.37	-0.26	-0.41	1.57	0.77	1.97

- Mn has high E^\ominus value.
- Comparatively low E^\ominus value of V.
- Comparatively low E^\ominus value of Fe.

26. A mixed oxide of iron and chromium $FeO \cdot Cr_2O_3$ is fused with Sodium Carbonate in presence of air to form a yellow coloured compound (A). On acidification the compound (A) forms an orange coloured compound (B) which is a strong oxidizing agent.

- Identify the compounds (A) and (B)
- Write balanced chemical equations for each step.

5 Marks Questions

27. (a) A blackish brown coloured solid (A) when fused with alkali metal hydroxides in presence of air produces a dark green compound (B), which on electrolytic oxidation in alkaline medium gives a dark purple compound (C). Identify (A), (B) and (C) and write balanced chemical equations for the reactions involved.

(b) What happens when an acidic solution of the green coloured compound (B) is allowed to stand for some time? Give the equation of the reaction involved. What is this type of reaction called?

(Hint: MnO_4^{2-} changes to MnO_4^-)

28. (A) reacts with H_2SO_4 to form purple coloured solution (B) which reacts with KI to form colourless compound (C). The colour of (B) disappears with acidic solution of $FeSO_4$. With concentrated H_2SO_4 (B) forms (D) which can decompose to give a black compound (E) and O_2 . Identify (A) to (E) and write equations for the reactions involved.

UNIT - 9

CO-ORDINATION COMPOUNDS

1 Mark Questions

1. Write the IUPAC name of the complex $\text{Na}_3[\text{Cr}(\text{OH})_2\text{F}_4]$.
2. Write the IUPAC name of $[\text{CO}(\text{en})_2\text{Cl}(\text{ONO})]^+$
3. Which of these cannot act as ligand and why: NH_3 , H_2O , CO , CH_4 . Give reason?
4. NH_3 is strong ligand NH_4^+ ion is not, why?
5. Which of the two is more stable $\text{K}_4[\text{Fe}(\text{CN})_6]$ or $\text{K}_3[\text{Fe}(\text{CN})_6]$.

2 / 3 Mark Questions

1. A coordination compound has a formula $(\text{CoCl}_3 \cdot 4\text{NH}_3)$. It does not liberate NH_3 but precipitates chloride ion as AgCl . Give the IUPAC name of the complex and write its structural formula.
2. How is stability of co-ordination compounds determined in aqueous solution? Select a complex formation reaction and write an expression for the stability constant of the complex. Mention the factors affecting stability of complexes.
3. Why do tetrahedral complex not show geometrical isomerism?
4. Write the correct formula for the following co-ordination compounds.
 $\text{CrCl}_3 \cdot 6\text{H}_2\text{O}$ (Violet, with 3 Chloride ions/ Unit formula)
 $\text{CrCl}_3 \cdot 6\text{H}_2\text{O}$ (Light green colour with 2 Chloride ions/ unit formula)
 $\text{CrCl}_3 \cdot 6\text{H}_2\text{O}$ (Dark green colour, with 1 Chloride ion/ unit formula)
5. Aqueous copper sulphate solution (blue in colour) gives:
 - a. a green precipitate with aqueous potassium flouride
 - b. a bright green solution with aqueous potassium chloride. Explain these experimental results.
6. Identify complexes with different geometries depending upon the type of hybridization.
(a) $[\text{Co}(\text{NH}_3)_6]^{3+}$ (b) $[\text{CoF}_6]^{3-}$
7. One mole of complex compound $\text{Co}(\text{NH}_3)_5\text{Cl}_3$ gives 3 moles of ions on dissolution in water. One mole of same complex reacts with 2 moles of $\text{AgCl}(\text{s})$. What is the structure of the complex and write its formula.
8. When an aqueous solution of Nickel (II) chloride is mixed with ethane-1,2 diamine(en) in the molar ratios en : Ni=1:1, 2:1 and 3:1, the green coloured solution finally turns violet. Explain the chemical reactions based on the data provided.

UNIT - 10
HALOALKANES AND HALOARENES

1 Iodoform gives the precipitate with AgNO_3 on heating while chloroform does not. Give reasons

2 The following reaction give 2 products.
Write their structures

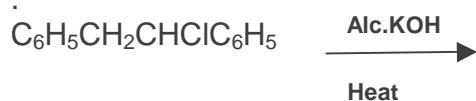

[hint: the 2 are geometrical isomers]

3 Predict the products of the following reactions:

a. HCl with $\text{CH}_3\text{CCl}=\text{CH}_2$

b. HBr with $\text{CH}_3\text{CH}=\text{C}(\text{CH}_3)_2$

4 Monochlorination of ethane to ethyl chloride is more practical than chlorination of n-pentane. Give reasons

5 An optically active compound having molecular formula $\text{C}_7\text{H}_{15}\text{Br}$ reacts with aq. KOH to give racemic mixture of products. Write the mechanism involved in the reaction.
[hint: a carbocation being planar, allows attack of nucleophile from either direction.]

6 a. Which of the following 2 compounds would react faster by $\text{S}_{\text{N}}2$ pathway:- 1-bromobutane or 2-bromobutane and why?

b. Allyl chloride is more reactive than n-propyl chloride towards nucleophilic substitution reaction. Explain why?

c. Haloalkanes react with KCN to give alkyl cyanides as main product while with AgCN , they form isocyanide as the main product. Give reasons.

7 In each of the following pairs of organic compounds, identify the compound which will undergo $\text{S}_{\text{N}}1$ reaction faster. Also give reason with related structures.

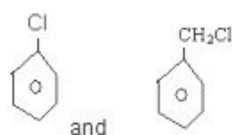
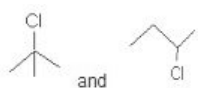

- 8 p-nitrobenzene undergoes nucleophilic substitution faster than chlorobenzene. Explain giving the resonating structures as well.
- 9 the structural formulas of the organic compounds. A, B, C, D in the following sequence of reactions

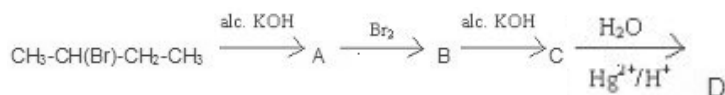

- 10 Rearrange the following in order of increasing ease of dehydrohalogenation: $\text{CH}_3\text{CH}_2\text{CH}_2\text{Cl}$, $\text{CH}_3\text{CHClCH}_3$, $\text{CH}_3\text{CCl}(\text{CH}_3)_2$. Give reasons.
- 11 Write formulae for structural and geometrical isomers of $\text{C}_3\text{H}_4\text{Cl}_2$.
[HINT: total 7 structures]
- 12 When toluene is chlorinated:
a. in presence of sunlight
b. in dark, in the presence of lewis acid, two separate compounds are obtained.
Explain with suitable mechanism.
- 13 Predict the order of reactivity of the following compounds in $\text{S}_{\text{N}}1$ and $\text{S}_{\text{N}}2$ reactions, giving reasons-
a. $\text{C}_6\text{H}_5\text{CH}_2\text{Br}$, $\text{C}_6\text{H}_5\text{CH}(\text{C}_6\text{H}_5)\text{Br}$, $\text{C}_6\text{H}_5\text{CH}(\text{CH}_3)\text{Br}$, $\text{C}_6\text{H}_5\text{C}(\text{CH}_3)(\text{C}_6\text{H}_5)\text{Br}$
The 4 isomeric bromobutanes
- 14 Arrange the following isomeric substituted haloarenes in ascending order of their reactivity towards NaOH to form corresponding substituted phenols.

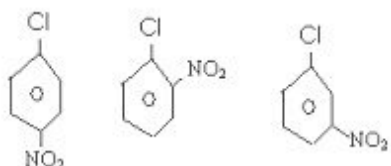

- 15 Arrange the following halocompounds in decreasing order of reactivity towards $\text{S}_{\text{N}}1$ nucleophilic substitution reaction, Vinyl chloride, Benzyl chlorides, iso propyl bromide.

UNIT-11

ALCOHOLS, PHENOLS & ETHERS

1 Marks Questions

1. Write the IUPAC name of the product formed by the catalytic reduction of Butanal.
2. How can you prepare Phenol from Aminobenzene.
3. Para-amino phenol is less acidic than phenol. Give reason.
4. Arrange the following alcohols in the order of increasing reactivity towards Lucas reagent:

2-butanol, 1-butanol, 2-methyl-2-propanol.
5. Which bond of alcohol is cleaved during its reaction with carboxylic acid?
6. Which structural isomer of butanol cannot be dehydrogenated by copper at 573K?

2 Marks Questions

7. Anisole reacts with HI to give phenol and methyl iodide and not iodobenzene and methylalcohol. Give reason.
8. Write the equations of the reactions which takes place when
 - I. Thionyl chloride is treated with 2-propanol.
 - II. Cumene hydroperoxide is treated with dil. H_2SO_4 .
9. Why is that the phenol is acidic and hexanol is neutral towards a solution of NaOH.
10. Out of benzene and phenol which is more easily nitrated and why?
11. A) di-tert-butyl ether cannot be made by Williamson's synthesis. Explain why?

B) name the carbocation formed when 3,3 di-2-butanol is treated with dilute acid.
12. Write the steps involved in the mechanism of acid catalysed hydration of propene.

13. Give a chemical test to distinguish between the following pairs of compounds

- I. Phenol and cyclohexanol.
- II. Propan-2-ol and benzylalcohol.

3 Marks Questions

14. An organic compound (A) having molecular formula C_6H_6O gives a characteristic colour with aqueous $FeCl_3$ solution (A) on treatment with CO_2 and $NaOH$ at 400 K under high pressure gives (B) which on acidification gives a compound (C). C reacts with acetyl chloride to give (D), which is a popular Pain Killer. Deduce the structures of (A), (B), (C) and (D).

15. Write the chemical equations and reaction conditions for the conversion of

- I. Phenol to salicylaldehyde.
- II. Methanol to ethanol
- III. Anisole to 4-methoxyacetophenone

16. Name the reagents for the following

- I. Oxidation of primary alcohol to aldehyde.
- II. Oxidation of primary alcohol to carboxylic acid.
- III. Dehydration of propan-2-ol to propene.
- IV. Reduction of butan-2-one to butan-2-ol.

17. Complete the following reaction

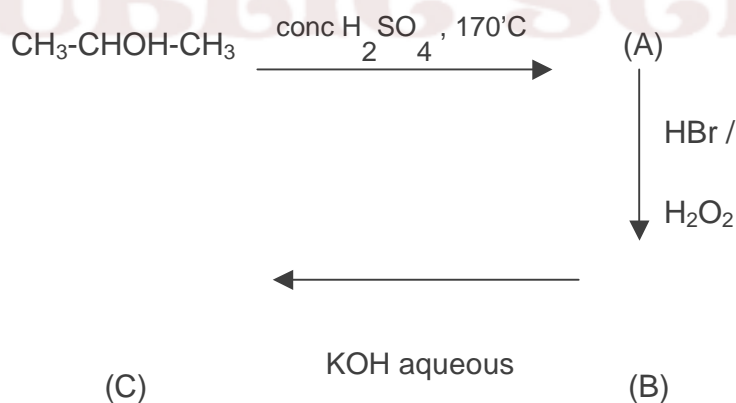

18. Compound (A) reacts with $SOCl_2$ to give compound (B). B reacts with Mg to form Grignard reagent which is treated with acetone and the product is hydrolyzed to give 2-methylbutan-2-ol. What are A and B compounds?

UNIT-12
ALDEHYDES KETONES AND CARBOXYLIC ACIDS

1-Mark Questions

1) Identify X.

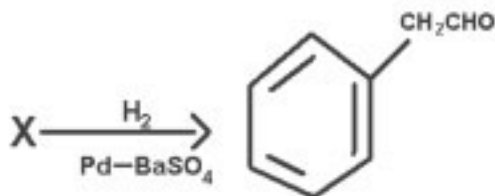

2) Identify B and C in the following reaction.

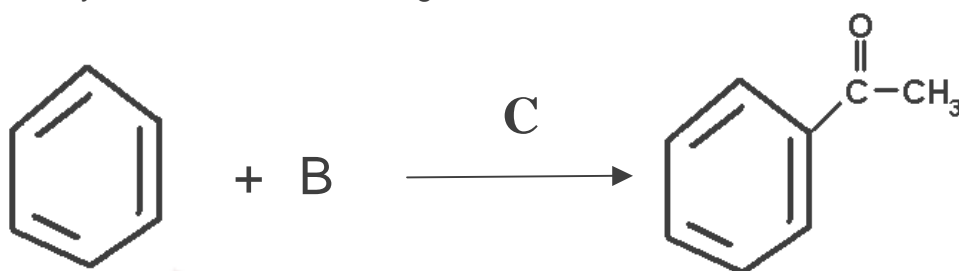

3) Arrange the following compounds in the increasing order of their boiling points.
 $\text{CH}_3\text{CH}_2\text{CH}_2\text{CH}_3$, $\text{CH}_3\text{OCH}_2\text{CH}_3$, $\text{CH}_3\text{CH}_2\text{CHO}$, CH_3COCH_3 , $\text{CH}_3\text{CH}_2\text{CH}_2\text{OH}$

4) Propanal is more reactive than propanone. Give the reason.

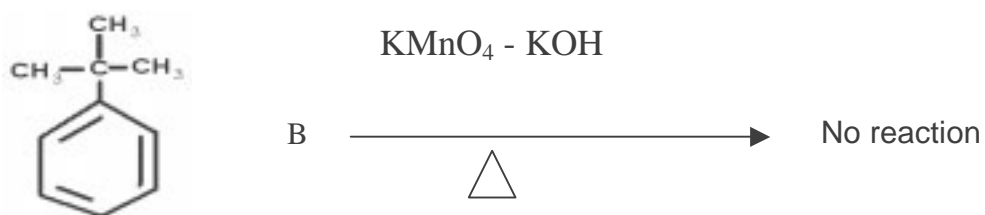
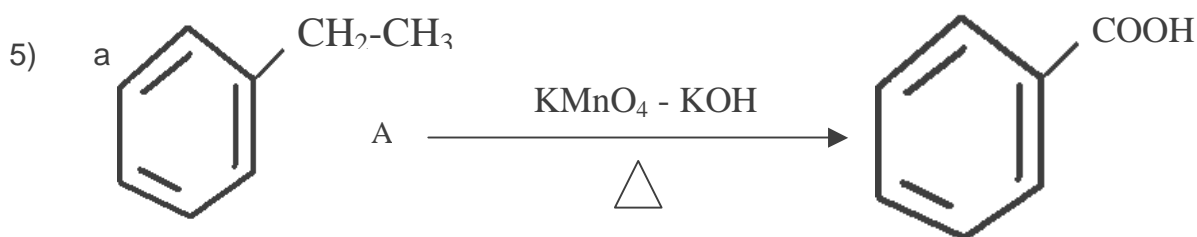

Observe the reactions and state why the compound A is oxidized whereas compound B is not oxidized by alkaline KMnO_4 ?

6) Which one among the following is the strongest acid?

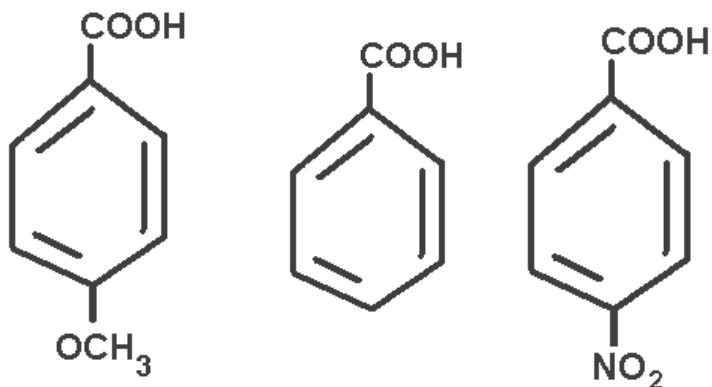

7) Identify the reagent used in the following conversion.

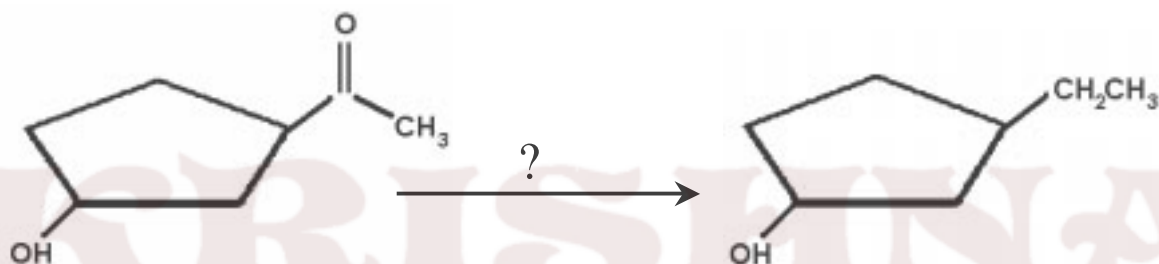

8) Fluorine is more electronegative than Chlorine even then P-Fluorobenzoic acid is weaker acid than P-Chlorobenzoic acid. State the plausible reason for this.

9) Identify A and B in the following reaction:

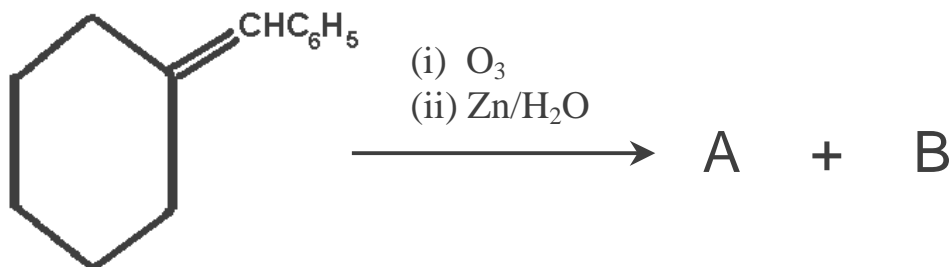

2- Mark Questions

10) For the reaction:

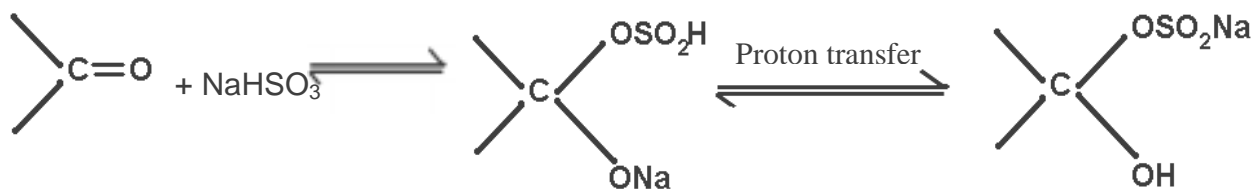

The position of equilibrium lies largely to the right hand side for most Aldehydes and to the left for most ketones. Find out the reason.

11) Identify the following named reactions and write the reagents used:

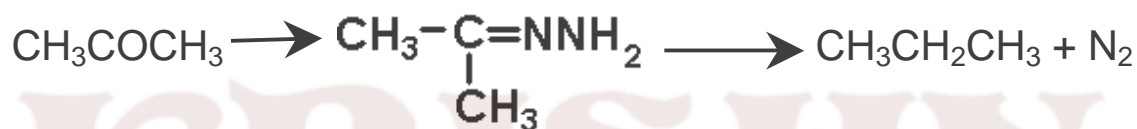

12) Aldol condensation of a ketone in presence of dilute alkali gives 4-Hydroxy -4-methylpentan-2-one. Write the structure of ketone and its IUPAC name.

13) Which among the following compounds give Cannizzaro reaction and state the reason?

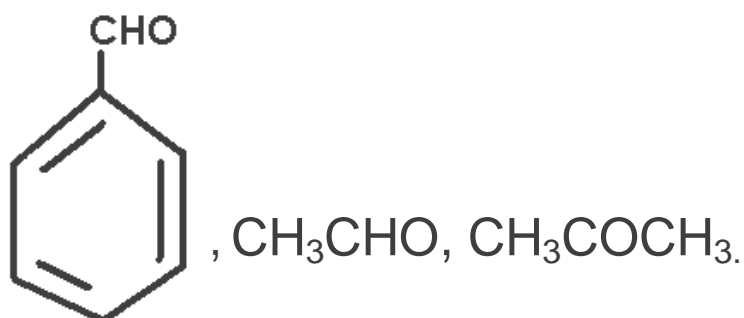

14) Predict the products of the following reactions:

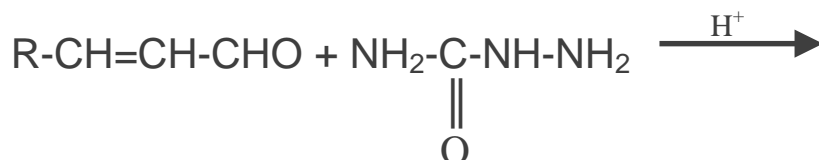
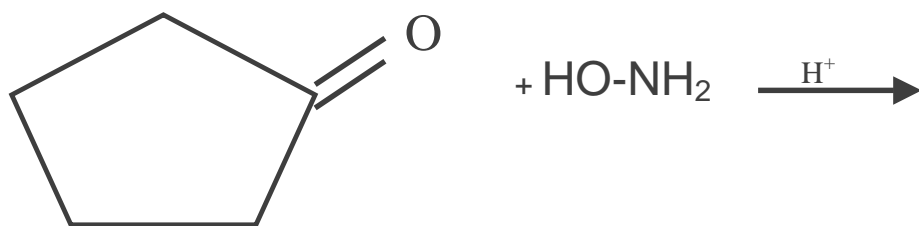

15) The decreasing order of acidity of a few carboxylic acids is given below:

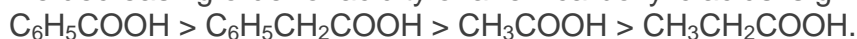

Explain plausible reason for the order of acidity followed.

16) An organic compound A, Molecular Formula C₉H₁₀O forms 2,4 DNP derivative, reduces Tollens reagent and undergoes Cannizaros reaction. On vigorous oxidation it gives 1,2-benzene dicarboxylic acids. Identify A.

(Hint: An aldehyde which do not contain α hydrogen atom.)

17) Do the following conversion using suitable reagents not more than two steps:

- Ethanol to 3-Hydroxy butanal.
- Bromobenzene to 1-phenyl ethanol.

18) Compound A C₄H₈Cl₂ is hydrolysed to a compound B C₄H₈O which form an oxime with NH₂OH and give negative Tollens test. What are the structures of A and B. Write balanced chemical equations for the reactions involved.

(Hint: A is a gemdihalide and B is a ketone)

19) Write the structure of the product and name the reaction.

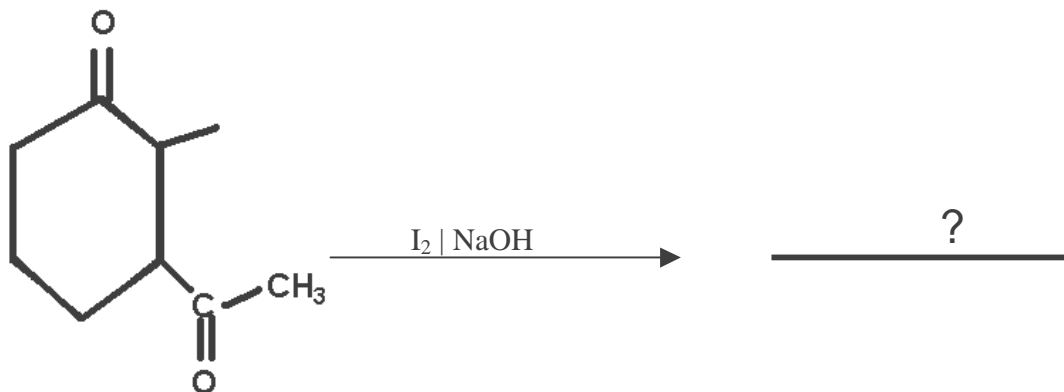

20) Give reasons for the following:

i) Iodoform is obtained when methyl ketones react with hypiodite but not with iodide.
(Hint: Hypiodite ion being stronger base than iodide ion, can easily remove acidic hydrogen atom.)

ii) Hydrazones of aldehydes and ketones are not prepared in highly acidic medium.
(Hint: In strong acidic medium N of reagent gets protonated to get an electrophile which cannot react.)

21) Both $\text{C}=\text{C}$ and $\text{C}=\text{O}$ give addition reactions. How do the addition reactions differ in both the cases and explain why?

Hint: $\text{C}=\text{C}$ Formed between two similar atoms having same electronegativity.

$\text{C}=\text{O}$ Formed between two different atoms with different electronegativities.

22) Benzaldehyde gives positive test with Tollens reagent but not with Fehlings solution. State the reason.

Hint: +R effect increases electron density on carbonyl group and C-H become strong.

$\text{Ag}(\text{NH}_3)_2^+$ is a stronger oxidizing agent than Cu^{2+} + tartarate + base.

23) Write the structures of the products in the following reactions:

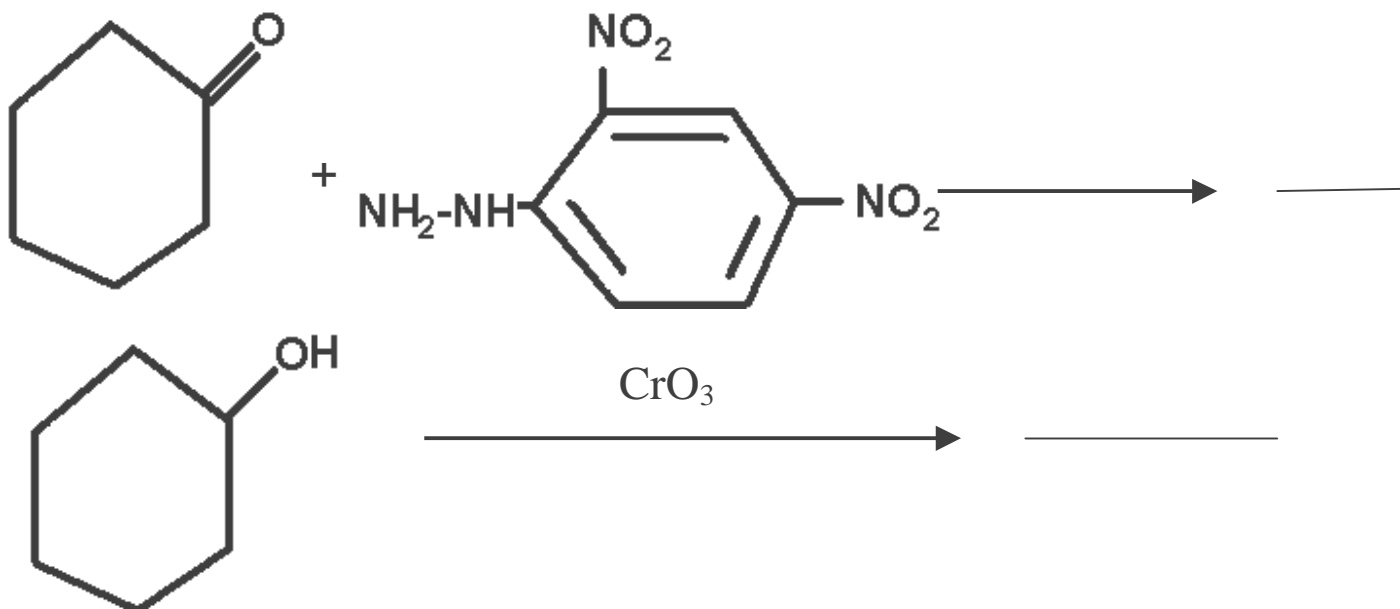

3-Mark Questions

24)

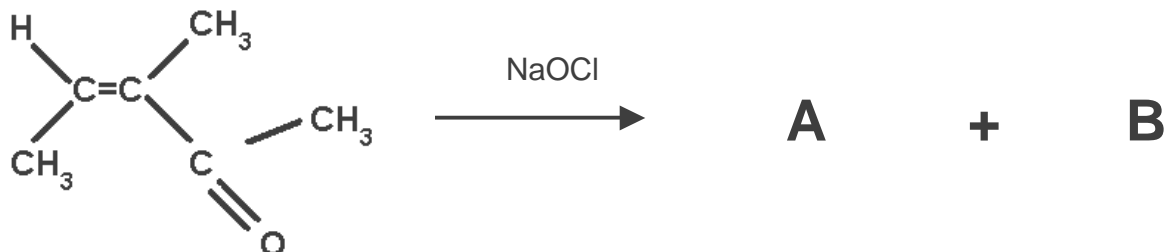

- Write the structures of A and B.
- Identify any two important features of this reaction.
(Hint: - Structural characteristics of compounds giving haloform reaction.)

25)

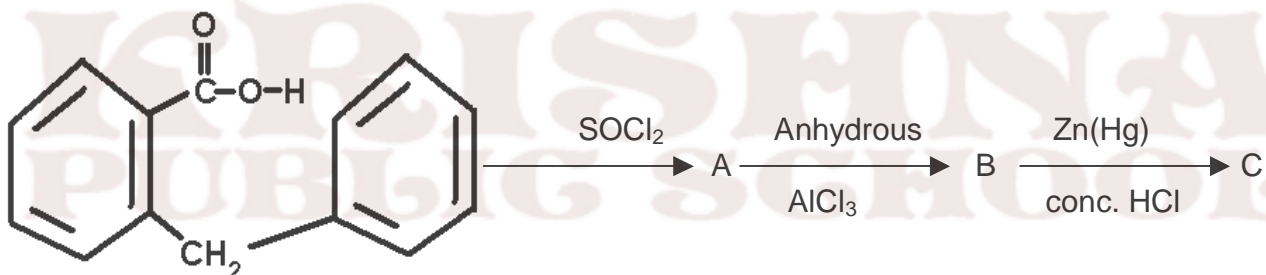

Write the structures of A, B and C.

- 26) Compound X, containing Chlorine on treatment with strong ammonia gives a solid Y which is free from Chlorine. Y on analysis gives C=49.31%, H=9.59% and N=19.18% and reacts with Br_2 and caustic soda to give a basic compound Z. Z reacts with HNO_2 to give ethanol. Suggest structures for X, Y and Z.

Hint:

Calculate the empirical formula of the compound. Y reacts with Br_2 and alkali indicates that it is amide.

- 27) Complete the following equation and write the structures of A, B, C, D, E and F.

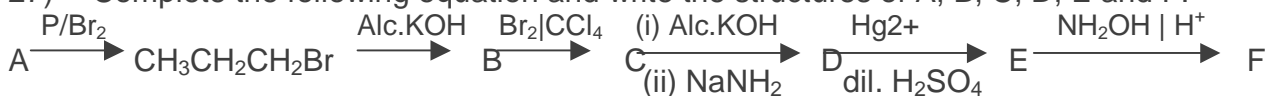

- 28) A compound X (C_2H_4O) on oxidation gives Y ($C_2H_4O_2$). X undergoes haloform reaction. On treatment with HCN, X forms a product Z which on hydrolysis gives 2-hydroxy propanoic acid.
- Write down the structures of X and Y.
 - Name the product when X reacts with dil. NaOH.
 - Write down the equations for the reactions involved.

Hint: - X is an aldehyde since it has general formula $C_nH_{2n}O$ and has only two carbon atoms.

5- Mark Questions

- 29) An alkene (A with molecular formula C_7H_{14}) on ozonolysis yields an aldehyde. The aldehyde is easily oxidized to an acid (B). When B is treated with Bromine in presence of Phosphorous it yields a compound (C) which on hydrolysis gives a hydroxy acid (D). This acid can also be obtained from acetone by the reaction with hydrogen cyanide followed by hydrolysis. Identify A, B, C and D and write the chemical equations for the reactions involved.
- 30) Five isomeric para-di- substituted aromatic compounds, A to E with molecular formula $C_8H_8O_2$ were given for identification. Based on the following observations give the structures of the compounds:

Both A and B form silver mirror with Tollens reagent, also B gives a positive test with $FeCl_3$.

C gives positive Iodoform test.

D is readily extracted in aqueous $NaHCO_3$ solution.

E on acid hydrolysis gives 1,4-dihydroxy benzene.

Hint: A and B contain CHO groups since they've shown positive Tollens test. B has phenolic group as it reacts with $FeCl_3$ solution. C should have $-CH_3CO$ group. D should have $-COOH$ group. E should be p-hydroxy phenyl vinyl ether.

UNIT – 13

AMINES

1 / 2 / 3 Marks Questions

1. Arrange the following in order of decreasing basic strength
 - (a) Ethyl amine, Ammonia, Triethyl amine
 - (b) Aniline, p- Nitroaniline , p- Toluidine
2. Amine group in aniline is ortho and para directing. Why does then aniline on nitration give substantial amount of m-nitroaniline
3. Primary amines have higher boiling points than tertiary amines. Why?
4. 'Amide are more acidic than amines'. Why?
5. Arrange the following amines in the ascending order of basic strength giving reason- EtNH_2 , Et_2NH , Et_3N , in aqueous solution?
6. Explain the role of mineral acid in the reaction of a carbonyl compound with KCN (aq)?
7. Why is acetonitrile preferred as a solvent for running organic reaction?
8. Why aniline is acetylated first to prepare mono bromo derivative?
9. Ammonolysis of alkyl halide does not give a corresponding amine in pure state. Explain?
11. Explain why methyl bromide reacts with KCN to give mostly methyl cyanide but it reacts with AgCN to give mostly methyl isocyanide.
12. Why is necessary to maintain the temperature between 273 K and 278 K during diazotization?
13. Why does silver chloride dissolve in aqueous methyl amine solution?
14. How can the following conversion be carried out :-
 - (a) p-toluidine to 2- bromo-4- methylaniline
 - (b) Aniline to iodobenzene
 - (c) Aniline to benzonitrile

UNIT-14
BIOMOLECULES

1 Mark Question

- 1 How many chiral centres are there in D-(-)-Fructose?
- 2 Where does the water present in the egg go after boiling the egg?
- 3 Why do monosaccharides form cyclic structures?
- 4 Name the α -amino acids obtained when tripeptide(Gly-Ala-Leu) is hydrolysed.
- 5 Explain how curdling of milk occurs. What structural changes take place?
- 6 Drugs which are proteins such as insulin cannot be taken by mouth but must be injected. Why?
- 7 .Amino acids show amphoteric behavior. Explain
- 8 In alkaline solution, an amino acid contains 2 basic groups – NH_2 and COO^- , which is more basic? If acid is added to the solution, what will happen?
- 9 In a quite acidic solution, the AA contains 2 acidic groups- NH_3^+ and COOH , which is more acidic? If a base is added to the solution, what will happen?
- 10 Sucrose is dextrorotatory. Its structure is given as:

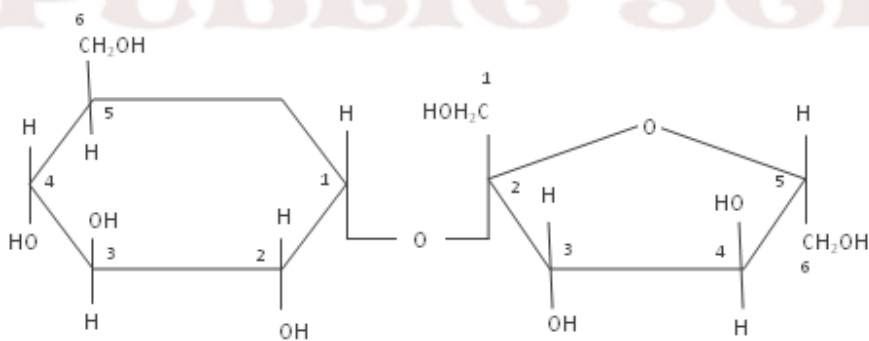

- a. What happens when sucrose solution is treated with tollen's reagent and why?
- b. Its aqueous solution exhibits a change in rotation . Why?

- 11 Starch forms an emulsion rather than solution with water. Explain.
- 12 The melting points and solubility in water of amino acids are generally higher than that of corresponding lab acids. Explain.
- 13 Activation energy for acid hydrolysis of sucrose is 6.22 kJ mol^{-1} while it is only 2.15 kJ mol^{-1} when hydrolysed by enzyme sucrose.
 - a) Write the mechanism of the enzyme catalysed reaction
 - b) Also depict the progress of reaction against energy in both cases, diagrammatically.
- 14 When DNA is hydrolysed, there is a definite relation among the quantities of different bases obtained. But for hydrolysis of RNA, it is not so. What does this suggest about the structure of DNA and RNA?
- 15 Identify and explain the various forces which stabilize protein structure.

KRISHNA
PUBLIC SCHOOL

UNIT - 15

POLYMERS

1 Mark Questions

1. Arrange the following polymers in the increasing order of their intermolecular forces. Also classify them as addition and condensation polymers: Nylon 66, Buna-S, Polythene
2. Give name and structure of reagent used for initiating a free radical chain reaction?
3. Why is cationic polymerisation preferred in case of Vinylic monomers containing electron donating groups?
4. Arrange the following in the increasing order of their intermolecular forces Nylon – 66, Buna-S, Polythene.

2 / 3 Marks Questions

1. State the significance of numbers in the polymer name nylon –6 and nylon – 66.
2. What are linear polymer and branched chain polymers. How do these differ from cross-linked polymers?
3. Write the difference between polyacrylates and polyesters.
4. Differentiate between chain growth and step growth polymerization.
5. Write the structure of a reagent used for initiating a free radical chain reaction.
6. Will you prefer to polymerize acrylonitrile under anionic or cationic polymerization?
7. How does the presence of CCl_4 influence the course of vinyl free radical polymerization?
8. Why does styrene undergo anionic polymerization easily?
9. How vulcanization does changes the character of natural rubber?

UNIT -16
CHEMISTRY IN EVERYDAY LIFE

1 Mark Question

- 1) Which among the following is a semi synthetic modification of penicillin
Erythromycin, ampicillin, tetracycline, ofloxacin.
- 2) Substances produced wholly or partly by chemical synthesis, which in low concentrations inhibits the growth or destroys microorganisms by intervening in their metabolic processes. Identify the substance.
- 3) Drugs are classified as
- | | | |
|------------------|---|--------------|
| Aspirin | – | analgesic |
| Chlordiazepoxide | – | tranquilizer |
| Penicillin | – | antibiotic |
- Mention on what basis the above classification is done?

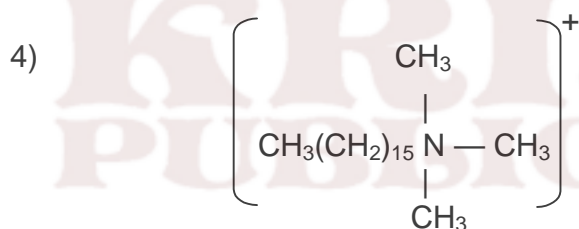

Identify the type of detergent given in the above structure.

- 5) Which of the following drug combinations is not correct and state why?
- | | | |
|-----------------|---|----------------------------|
| Chloramphenicol | – | broad spectrum antibiotic. |
| Equanil | – | sedative. |
| Phenacetin | – | antipyretic. |
| Bithional | – | tranquilizer. |

2 Mark Questions

6) Analysis of water in a place shows that the water contains Magnesium Chloride. The people in that place are advised to use detergents for washing clothes. Why?

7) Pick out the odd one from the following and mention why?

Erythromycin, penicillin, tetracycline, chloramphenicol

8) Antiallergics and antacids are antihistamines. Can antiallergics be used to reduce the acidity of the stomach? Give plausible reason for your answer.

9) Following drugs are used as analgesics. One among them is different from others. Identify it and state the reason.

Morphine, Heroin, Aspirin, Codeine.

10)

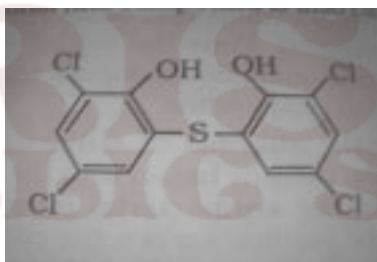

- i. Identify the compound.
- ii. What is its use?

11) Birth control pills essentially contain a mixture of synthetic estrogen and progesterone. What are estrogen and progesterone? Why are they used in birth control pills?

12) Sodium and Potassium soaps are only used for cleaning purposes. Why?

13) Detergents containing unbranched chains are more preferable than those containing branched chains. State the reason.

14) Low level of noradrenalin is the cause of depression. Suggest drugs to cure this problem?

3 Mark Questions

15) Observe the diagram and answer the questions given below:

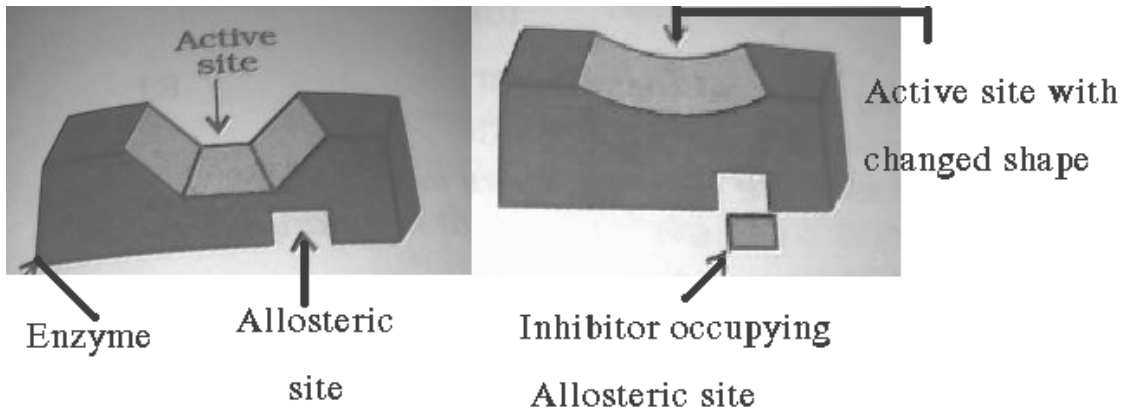

- Name the drug target.
- What is meant by allosteric site?
- Mention the role of inhibitors.

16) Observe and identify the steps a, b, c from the diagram given below:

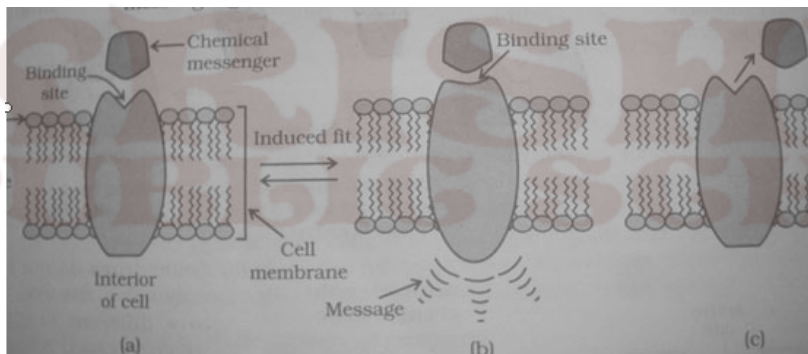

17) Sodium hydrogen carbonate and ranitidine are used as antacids. Which one is a better choice? Why?

18) Identify the following substances:

- It is about 550 times as sweet as cane sugar and excreted from body in urine unchanged.
- It is 100 times as sweet as cane sugar and its use is limited to cold food and soft drinks as it is unstable at cooking temperature.
- It is a trichloro derivative of Sucrose and it is stable at room temperature.

VALUE BASED QUESTIONS IN CHEMISTRY FOR CLASS - XII

Scuba divers when come towards the surface, the pressure gradually decreases resulting in the released of dissolved gases leading to formation of bubbles of nitrogen gas in the blood which blocks the capillaries and thus harmful kinds are created. To avoid bends and toxic effects of high concn of nitrogen gas, the air is diluted with helium. After reading the above passage, answer the following questions.

- i) Why is the harmful condition of bends overcome by the use of helium.
 - ii) Which law is used to calculate the concentration of gases in solution.
 - iii) Mention the value associated with providing divers air diluted with helium.
- (2) Ram takes a open pan to cook vegetables at a hill station while shyam cook the same vegetables in a pressure cooker at the same place.
- (a) Explain with reason who will cook vegetable faster.
 - (b) Mention the reason for the delay in cooking.
 - (c) Which value is learnt by the student in the process of cooking food in the pressure cooker.

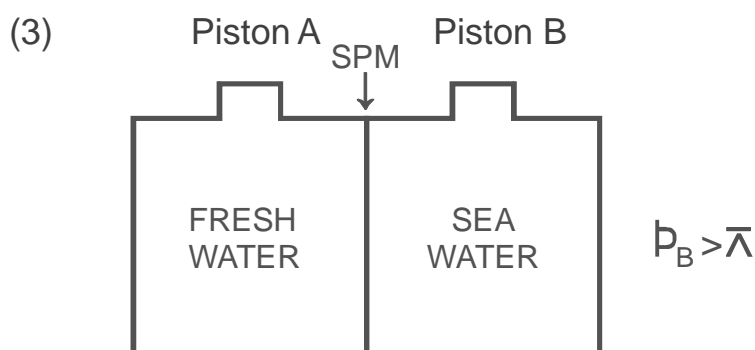

- a) Name the process observed when pressure on solution side is more than osmotic pressure.
 - (b) Write main use of this process.
 - (c) Mention the values associated with the above process.
- (4) Reena planted neem tree in school premisses and Meena planted Neem tree in marshy land near railway line.

- (a) Which student planted Neem tree correctly and why?
- (b) Name the chemical substances used to stop decay of such plants.
- (c) Mention the values by the plantation.
- (5) People are advised to limit the use of fossil fuels resulting in Green House Effect leading to a rise in the temperature of earth. Hydrogen provides an ideal alternative and its combustion in fuel cells.
1. Write electrode reaction in H_2-O_2 fuel cell.
 2. How is green house effect reduced by the use of fuel cells?
 3. Write the values associated with preference of using fuel cells to fossil fuel.
- (6) In Apollo Space programs, hydrogen-oxygen fuel cell was used.
- (a) Explain why, fuel cell is preferred in space programme.?
- (b) Mention the values associated with the decision of using fuel cell?
- (7) Ira a student of science went with her grandfather to buy a battery for their inverter and camera. They found two types of batteries, one a lead storage battery and other a Nickel-Cadmium storage battery. Later was more expensive but lighter in weight. Ira insisted to purchase costlier Nickels-Cadmium battery.
- (a) In your opinion, why Ira insisted for Nickel-Cadmium battery? Give reasons
- (b) Write the values associated with above decision?
- (8) Shyam's father wants to buy a new car. In the market various options are available. Shyam persuades his father to buy a hybrid car which can run both on electricity as well as on petrol.
- (i) Mention the values associated with this decision.
 - (ii) Name the battery used for running the car.
 - (iii) Write the reactions taking place at the anode and cathode of battery.
- (9) Ajay, a student of chemistry, was performing chemical reaction between sodium thiosulfate and HCl. He found that time required to appear turbidity increases when concentration of HCl or sodium thiosulfates or both decreases.
- (a) Mention the reason for appearance of turbidity.

- (b) Write the chemical reaction involved.
- (c) Mention the values associated with above experiment.
- (10) Smoke is colloidal solution of solid particles such as Carbon, arsenic compounds dust, etc. in air. Precipitation of smoke particles coming from the chimney of factories is carried out by Cottrel Precipitator and Carbon free air passes out through the chimney.
- (a) Name the principle used in the Cottrel Precipitator.
- (b) How smoke precipitator causes precipitation and settling of smoke particles.
- (c) Name the value learnt by the use of this Cottrel Precipitator.
- (11) While coming back from school, a student witnesses an accident on road. A person on bike had suffered injuries due to skidding of bike. The student rushed to the aid of biker with the help of some people, the biker was taken to a nearby hospital. The student discovered that the bike skidded due to oil spilled on road. The student arranged for an old cloth and wiped the oil from the road.
- i) Mention the values shown by the student in the above case.
- ii) The oil spill can also be washed with soap and water. Explain the cleaning action of soap.
- (12) Chlorofluorocarbons (CFC) and gas emitted from the exhaust system of supersonic aeroplanes might be slowly depleting the concentration of the ozone layer in the upper atmosphere.
- (a) Name the gas emitted by the exhaust of supersonic jet aeroplanes.
- (b) Write the chemical reactions involved in the ozone layer depletion.
- (c) Mention the values that are learnt by the students in this depletion of ozone layer.
- (13) A student accidentally spills concentrated H_2SO_4 on his hand. Before the teacher gets to know, his friend washed his hands with water and also with soap but the burning sensation on hand was still going on. The friend then rubs solid sodium bicarbonate on his hand and then washed with water, finally the burning sensation is relieved.
- (i) Mention the values shown by student's friend.
- (ii) Can you recommend any other substance available in the laboratory which can be used instead of sodium bicarbonate?

- (iii) Write the chemical reaction involved in the treatment of acid burn with sodium bicarbonate.
- (14) Ramu, a caretaker of swimming pool was using chlorine for disinfecting swimming pool water. His friend Jagat an another swimming pool caretaker was using ozone in place of chlorine.
- (a) In your opinion, which is better way of disinfecting water in a swimming pool.
- (b) Mention reason and values associated with your reply.
- (15) A trainee pilot was flying his plane in stratosphere. His senior advised him not to fly the aeroplane in the stratosphere.
- (a) In your opinion, why the senior pilot advised his trainee pilot not to fly his plane in the strostosphere.
- (b) Write the possible chemical reaction.
- (c) Mention the values associated with your reply.
- (16) During world war II, mustard gas was used to kill innocent people by Adolf Hitler, though science should always be used for betterment of human race.
- (i) Write the formula of mustard gas.
- (ii) Name the value obtained from the above mentioned paragraph.
- (17) Police usually disperse the indisciplined mob by using tear gas shells. One of the person in the mob advised the people either to use water wetted cloth on eyes or to avoid the smoke
- (i) Write the chemical formula of compound used in tear gas and reaction involved.
- (ii) Write the value involved as advised by one person present in the mob.
- (18) Recently a blanket ban is imposed on use of any kind of ploythene bags in Delhi. Polythene is supposed to be non-biodegradable and creates an environmental garbage but some poythene manufacturing units opposed this decision.
- (i) Which value is missing in the polythene manufacturing traders?
- (ii) Name one important catalyst used in the manufacturing of polythene.
- (iii) Write the chemical formula of polythene, polypropylene and PVC.

- (19) Recently Delhi Police launched a special drive to curb the crimes and accidents related to “Drunken-Driving” An instrument known as “Alcometer” is used to test whether a driver has consumed alcohol or not.
- Write the name and chemical formula of the compound used in alcometer.
 - By preventing alcohol drinking during driving. Name the value, which Delhi Police tries to inculcate in drivers and general public.
 - Write the chemistry involved in the above test.
- (20) A group of students was smoking cigarettes in college premises. A social activist, noticed and advised them not to smoke as smoking is injurious to health.
- By forbidding them not to smoke, which value social activist want to be inculcated among the youth.
 - As a chemistry student, write the name of “Alloy” used in lighter’s flint.
 - Mention diseases caused by smoking.
- (21) In a terrorist activity in the Mumbai nearly ten persons were killed and 50 injured due to continuous showering of bullets on them by terrorists. A group of persons rushed to the spot immediately and helped the injured to reach the nearby hospital.
- Which kind of value is reflected by these persons by doing this?
 - Which alloy is used in the preparation of bullet?
- (22) It is a general belief that we should not come out of the house to see “Solar Eclipse” because it can have evil impact on life but nowadays educated people allow their children to see solar eclipse, treating it as a natural science phenomenon, but children are advised to see them by U.V. protected sun glasses (crooke’s lenses) to avoid harmful impact of UV light on eyes.
- Write the name of transition metal oxide used in making U.V protected lens.
 - By allowing the children to see solar eclipse using U.V. protected lens which value the educated people trying to inculcate in the children.
 - Which rays are present in the light which can damage the eye while viewing solar eclipse with naked eye.
- (23) Hard water does not form leathers with soap. Rita uses a washing powder containing sodium metapolyphosphate and ethylenediamine tetracetate (EDTA) while Sita is using ordinary washing power.

- (a) Which washing powder is more effective for washing clothes in hard water and why?
- (b) Name the values associated with the above passage.
- (24) A lot of children, working in a lead industry were rescued by NGO's activists. The children sent to the hospital and found to be excess exposure to lead so called lead poisoning.
- (i) Name the ligand (compound) used for treatment of Lead poisoning.
- (ii) During this rescue operation which values are shown by NGO's activists?
- (iii) Write the reaction involved for removal of lead from living organism.
- (25) Cancer is not a communicable disease. It occurs due to unlimited growth of body cells leading to tumours. We should shake hand, eat together with people suffering from cancer. These activities boost up the confidence in them for living.
- (i) Write the name of coordination compound used as a chemotherapeutic agent to curb the growth of tumours.
- (ii) By showing such attitude to cancer patients, mention the values reflected by us.
- (26) Ravi Prasad, a farmer has 25 acres of land. He noticed some infection on the leaves of his crops. He called his friend Raghav, who advised him to use DDT. However, Ravi Prasad preferred to use dry powder of neem leaves as an insecticide.
- (a) Mention reason why Ravi Prasad prefer using neem powder?
- (b) In your opinion, who took right decision?
- (c) Write values associated with above decision?
- (27) A manufacturer dealing in A.C plant was using Freon-12 in his AC plant. His friend Raju, who also deals in similar business, was using liquid ammonia in place of Freon-12.
- (i) In your opinion, Who is using right compound in refrigeration plants.
- (ii) Mention values associated with above opinion.
- (28) In a locality a large number of people fell ill after drinking liquor sold by a local vender. Many people started vomiting, some shouted that they are not able to see properly and some others went unconscious. Ram's father also

suffered from severe stomach ache after consuming liquor. Everyone in Ram's family peaked. Neighbours family was also weeping loudly. Ram calmed down his mother and helped her to call ambulance for his father and also for other people. They also informed the police about the incident.

- (i) Mention the values shown by Ram.
 - (ii) Write the probable cause of poisoning by liquor.
 - (iii) Write the reaction showing the conversion of ,mollases to Ethyl alcohol using yeast.
- (29) Some students enter the chemistry lab for doing practical. Some students are not serious about learning and want to create trouble. They remove the lables from two bottles containing methanol and dimethyl ether. Mohan approaches the teacher and informs about the incident.
- (i) Mention the values shown try Mohan.
 - (ii) If the teacher asks the some students to perform chemical test to identify methanol and demethyl ether, write the reaction involved for the test.
- (30) An owner of a paint company who was using ethanol as solvent noted that his stock of ethand was misused by his employee.
To prevent this misuse, he decided to add small amount of a bule colour compound (A) and another nitrogen containing heterocyclic base (B) which gives a foul smell to alcohol.
- (a) Do you think that he took right decision?
 - (b) Write the names of compound A& B ? Name process of adding compound A & B to ethanol ?
 - (c) Mention the values associated with above decision.
- (31) Arpita wanted to buy vanilla ice cream from a local ice cream vendor. Her friend Amita told her that these vendor use synthetic chemical compound vanillin whose flavor is similar to that of vanilla. They decided not to buy such ice creams.
- (i) Write the Chemical formula and IUPAC name of vanillin.
 - (ii) Write values that are associated with above decision.
- (32) Kabir is fond of eating too much of chowmein loaded with cabbage leaves. At the age of fifteen his teeth got rotten and he started complaining of severe headache. His mother took him to a doctor who after examining found that Kabir is suffering from neurocysticercosis, a mental disease caused

by larvae of tape worm.

After reading the above paragraph, answer the questions.

- (a) Name the chemical substance responsible for damaging Kabir's teeth.
- (B) Is there any link between eating of too much of chowmein and his headache.
- (c) Mention the values conveyed by above paragraph.
- (33) Sushil's friend want to play Holi with synthetic colours, eggs, muddy water etc. Sunil persuades his friends to play Holi with natural colours. He reminds them that last time one of their friends had developed skin allergy after playing Holi with synthetic colours. It took him a long time to recover. Sushil's friends agreed and prepared natural colours using leaves and flowers.
- (i) Mention the values shown by Sushil.
- (ii) Write the names and reaction of preparation of two azo dyes (synthetic)
- (iii) Write the name of two pigments present in natural colours.
- (34) Nita's mother fell ill and the doctor diagnosed her with pernicious anemia. She felt lethargic and did not have the energy to do work. Nita helped her mother in household work till she recovered.
- (i) Name the vitamin whose deficiency caused pernicious anemia.
- (ii) Name the sources which will provides this vitamin.
- (iii) Mention the values shown by Nita.
- (35) Two shopkeepers are using LDP (Low Density Polythene) and HDP (High density Polythene) polymers for packing of materials.
- (i) Name the ploythene preferred for packaging.
- (ii) Name the catalyst used in the synthesis of HDP.
- (iii) Mention the values associated with the use of a specific polymer.
- (36) PHBV (Poly-B-Hydroxybutyrate-Co- β -hydroxy valerate) is a biodegradable polymer. It is a copolymer of 3-hydroxy valerate acid and 3-hydroxy pentanic acid.
- (a) How PHBV has found utility in medicines as Capsule?
- (b) Write the name of polymer used in artificial limb popularly known as Jaipur foot.

- (c) Mention the values associated with the use of such polymers.
- (37) In a school, lot of emphasis is given to the 3R principle of Reduce, refuse and Recycle. The students observe their teachers following it and they are made to follow it in school. Rita also follows at home and always tries to save paper. She also keeps waste paper and waste items separately so that they be sent for recycling. She does not use plastic bags and takes a jute bag with her while going to the market.
- Mention the values shown by Rita.
 - If the jute bag is made of cellulose polymer, and name the monomer.
 - Name the chemical substance used in cotton, Jute and Rayon fibre.
- (38) In order to wash clothes with water containing dissolved calcium hydrogen carbonate, which cleansing agent will you prefer and why, soap or detergent? Give one advantage of soap and synthetic detergent.
- Mention the values associated with the use of soap.
 - Name the chemical used in shaving soaps.
- (39) Rama's younger brother is suffering from cold, cough and fever. Rama's father did not take him to the doctor and wanted to give medication on his own. Rama tells her father that he should not give medicines to her brother on his own but should take him to a doctor.
- (/8) Mention the values shown by Rama?
- Why should not medicines be taken without consulting doctors?
 - While antacids and antiallergic drugs interfere with the action of histamines, why do these not interfere with the function of each other?
- (40) Ravi observed that his classmate Manish was showing a change in behaviour over some time, Manish stayed aloof, did not mix with friends and had become easily irritable. He avoided going to any type of get-together also. Ravi shares his concerns with his class teacher who has also observed these things about Manish. The teacher calls Manish's parents and advise them to consult a doctor. Doctor prescribes antidepressant drugs for him.
- Name the antidepressant drugs? How are they classified. Give examples of each class.
 - Mention the values shown by Ravi.

(41) Harish was feeling headache. His friend Vikram observed that Harish had fever. He advises him to take two tablets of flaxin-200 mg

(a) In your opinion, is it right to take medicine as per your friend's advice?

(b) Give reasons for your reply.

(c) Write values associated with his friend's decision.

(42) Rajni asked her maid to prepare halwa for her diabetic mother-in-law. Her maid added sugar-free tablets containing two amino acids in the boiling contents. Rajni scolded her maid for this action.

Q. In your opinion, why did Rajni do so?

Q. Mention values associated with your opinion.

(43) A laundry engaged in washing clothes has been pouring waste water directly into the river. Over a period of time, it was found that a large number of fish were dying in the river.

Q. Mention the reasons for the above problem. Can it be avoided?

Q. Mention values associated with the above situation.

VARIOUS VALUES ASSOCIATED

- 1 Critical thinking and self awareness.
- 2 Energy conservation
- 3 Water conservation
- 4 Environmental conservation
- 5 Environmental conservation
- 6 Environmental conservation
- 7 Environmental conservation
- 8 Environmental conservation
- 9 Critical thinking & problem analysis
- 10 Environmental conservation
- 11 Social responsibility
- 12 Environmental conservation
- 13 Inclusion and dignity of individual
- 14 Self awareness and decision making
- 15 Critical thinking and decision making
- 16 Dignity of individual

- 17 Social responsibility and social justice
- 18 Environmental conservation
- 19 Appreciation of cultural values and dignity of individual
- 20 Interplay of different cultures.
- 21 Principle of equality and social justice
- 22 Scientific attitude
- 23 Water and Environmental conservation
- 24 Dignity of individual
- 25 Self awareness
- 26 Environmental conservation
- 27 Environmental conservation
- 28 Social justice, awareness, respect for diversity
- 29 Inclusion
- 30 Critical thinking and decision making.
- 31 Self awareness, critical thinking.
- 32 Self awareness, dignity of individual.
- 33 Environmental conservation, respect of multireligious and multicultural country.
- 34 Self awareness.
- 35 Environmental conservation
- 36 Dignity of individual
- 37 Environmental conservation
- 38 Environmental conservation
- 39 Self awareness and dignity of individual
- 40 Principle of equality and social justice
- 41 Critical thinking
- 42 Self awareness
- 43 Environmental conservation

14. The packing efficiency in **bcc** = $2 \times \frac{4}{3} \times \pi r^3 / 64 \times 3^{3/2} r^3 \times 100 = 68$

15. The packing efficiency in **hcp** = **74**

16. Packing efficiency in bcc arrangement is 68% and simple cubic unit cell is 52.4%

17. Unoccupied spaces in solids are called interstitial voids or interstitial sites.

18. Two important interstitial voids are (I). Tetrahedral void and (II). Octahedral void.

19. Radius ratio is the ratio of radius of void to the radius of sphere.

a. For tetrahedral void radius ratio=0.225

For octahedral void radius ratio=0.414

20. No. of tetrahedral void = $2 \times N$ (N = No. of particles)

21. No. of octahedral void = N

22. Formula of a compound depends upon arrangement of constituent of particles.

23. Density of unit cell

$$D = Z \cdot M / a^3 \cdot N_A$$

D = density, M = Molar mass, a = side of unit cell, $N_A = 6.022 \times 10^{23}$

24. The relationship between edge length and radius of atom and interatomic or interionic

distance for different types of unit is different as given below

a. Simple cubic unit cell $a = 2R$

b. FCC $a = 4R / \sqrt{2}$

c. BCC $a = 4R / \sqrt{3}$

25. Interatomic distance = $2R$

26. Interionic distance = $R_c + R_a$ (R_c = Radius of cation, R_a = Radius of anion)

27. Imperfection is the irregularity in the arrangement of constituent particles.

28. Point defect or Atomic defect -> it is the deviation from ideal arrangement of constituent

atom. Point defects are two types (a) Vacancy defect (b) Interstitial defect

29. Vacancy defect lowers the density and

30. Interstitial defect increases the density of crystal.
31. Point defects in the ionic crystal may be classified as:
- Stoichiometric defect (Ratio of cation and anion is same).
 - Non Stoichiometric defect (disturb the ratio).
 - Impurity defects (due to presence of some impurity ions at the lattice sites)
32. Schottky defect lowers the density of crystal it arises due to missing of equal no. of cations of anions from lattice sites e.g. NaCl.
33. Frenkel defect is the combination of vacancy and interstitial defects. Cations leave their actual lattice sites and come to occupy the interstitial space density remains the same e.g. AgCl.
34. Non stoichiometric defect
- Metal excess defect due to anion vacancy.
 - Metal excess due to presence of interstitial cation.
 - Metal deficiency due to absence of cation.

SHORT ANSWER QUESTION (2)

Q1. What do you mean by paramagnetic substance?

Ans: - Attracted by magnetic field and these substances are made of atoms or ions with unpaired electrons.

Q2. Which substance exhibit Schottky and Frenkel both defects.

Ans: - AgBr

Q3. Name a salt which is added to AgCl so as to produce cation vacancies.

Ans: - CdCl₂

Q4. Why Frenkel defects not found in pure Alkali metal halide.

Ans: - Due to larger size of Alkali metal ion.

Q5. What is the use of amorphous silica?

Ans. Used in Photovoltaic cell.

Q6. Analysis shows that a metal oxide has the empirical formula $\text{Mo}_x\text{O}_{1.00}$. Calculate the percentage of M^{2+} and M^{3+} ions in the crystal.

Ans: - Let the M^{2+} ion in the crystal be x and $\text{M}^{3+} = 0.98 - x$

Since total charge on the compound must be zero

$$2x + 3(0.98 - x) - z = 0$$

$$x = 0.88$$

$$\% \text{ of } \text{M}^{2+} = \frac{0.88}{0.96} \times 100 = 91.67$$

$$\% \text{ of } \text{M}^{3+} = 100 - 91.67 = 8.33$$

Q7. What is the co-ordination no. of cation in Antifluorite structure?

Ans: - 4

Q8. What is the Co.No. of cation and anion in Caesium Chloride.

Ans: 8 and 8

Q9. What is F centre?

Ans:- It is the anion vacancy which contains unpaired electron in non-stoichiometric compound containing excess of metal ion.

Q10. What makes Alkali metal halides sometimes coloured, which are otherwise colourless?

Very Short Answers(1 marks) :

1. How does amorphous silica differ from quartz?

In amorphous silica, SiO_4 tetrahedral are randomly joined to each other whereas in quartz they are linked in a regular manner.

2. Which point defect lowers the density of a crystal?

Schottky defect.

3. Why glass is called super cooled liquids?

It has tendency to flow like liquid.

4. Some of the very old glass objects appear slightly milky instead of being transparent why?

Due to crystallization.

5. What is anisotropy?

Physical properties show different values when measured along different in crystalline solids.

6. What is the coordination number of atoms?

a) in fcc structure b) in bcc structure

a) 12

b) 8

7. How many lattice points are there in one cell of -

a) fcc b) bcc c) simple cubic

a) 14

b) 9

c) 8

8. What are the co-ordination numbers of octahedral voids and tetrahedral voids?

6 and 4 respectively.

9. Why common salt is sometimes yellow instead of being of being pure white?

Due to the presence of electrons in some lattice sites in place of anions these sites act as F-centers. These electrons when excited impart color to the crystal.

10. A compound is formed by two elements X and Y. The element Y forms ccp and atoms of X occupy octahedral voids. What is formula of the compound?

No. of Y atoms be N

No. of octahedral voids N

No. of X atoms be =N

Formula XY

HOTS Very Short Answers:

1. Define F centers.
2. What type of stoichiometric defect is shown by
 - a. ZnS
 - b. AgBr
3. What are the differences between Frenkel and Schottky defect?
4. Define the following terms with suitable examples
 - Ferromagnetism
 - Paramagnetism
 - Ferrimagnetism
 - 12-16 and 13-15 group compound
5. In terms of band theory what is the difference
 - Between conductor and an insulator
 - Between a conductor and a semi-conductor

Short Answers (2 Marks):HOTS

1. Explain how electrical neutrality is maintained in compounds showing Frenkel and Schottky defect.

In compound showing Frenkel defect, ions just get displaced within the lattice. While in compounds showing Schottky defect, equal number of anions and Cations are removed from the lattice. Thus, electrical neutrality is maintained in both cases.

2. Calculate the number of atoms in a cubic unit cell having one atom on each corner and two atoms on each body diagonal.

$$8 \text{ corner} \times \frac{1}{8} \text{ atom per unit cell} = 1 \text{ atom}$$

There are four body diagonals in a cubic unit cell and each has two body centre atoms.

So $4 \times 2 = 8$ atoms therefore total number of atoms per unit cell $= 1 + 8 = 9$

3. Gold crystallizes in an FCC unit cell. What is the length of a side of the cell ($r = 0.144 \text{ nm}$)

$$r = 0.144 \text{ nm}$$

$$a = 2\sqrt{2}r$$

$$= 2 \times 1.414 \times 0.144 \text{ nm}$$

$$= 0.407 \text{ nm}$$

4. Classify each of the following as either a p-type or n-type semi-conductor.

a) Ge doped with In

b) B doped with Si

(a) Ge is group 14 elements and In is group 13 element. Therefore, an electron deficit hole is created. Thus semi-conductor is p-type.

(b) Since b group 13 element and Si is group 14 elements, there will be a free electron, thus it is n-type semi-conductor.

5. In terms of band theory what is the difference between a conductor, an insulator and a semi-conductor?

The energy gap between the valence band and conduction band in an insulator is very large while in a conductor, the energy gap is very small or there is overlapping between valence band and conduction band.

6. CaCl_2 will introduce Scotty defect if added to AgCl crystal. Explain

Two Ag^+ ions will be replaced by one Ca^{2+} ions to maintain electrical neutrality. Thus a hole is created at the lattice site for every Ca^{2+} ion introduced.

7. The electrical conductivity of a metal decreases with rise in temperature while that of a semi-conductor increases. Explain.

In metals with increase of temperature, the kernels start vibrating and thus offer resistance to the flow of electrons. Hence conductivity decreases. In case of semi-conductors, with increase of temperature, more electrons can shift from valence band to conduction band. Hence conductivity increases.

8. What type of substances would make better permanent magnets, ferromagnetic or ferromagnetic, why?

Ferromagnetic substances make better permanent magnets. This is because the metal ions of a ferromagnetic substance are grouped into small regions called domains. Each domain acts as tiny magnet and get oriented in the direction of magnetic field in which it is placed. This persists even in the absence of magnetic field.

9. In a crystalline solid, the atoms A and B are arranged as follows:-

a. Atoms A are arranged in ccp array.

b. Atoms B occupy all the octahedral voids and half of the tetrahedral voids. What is the formula of the compound?

Let no. of atoms of A be N

No. of octahedral voids = N

No. of tetrahedral voids = $2N$

- i) There will be one atom of b in the octahedral void
 - ii) There will be one atom of B in the tetrahedral void ($1/2 * 2N$)
- Therefore, total 2 atoms of b for each atom of A

Therefore formula of the compound = AB_2

10. In compound atoms of element Y forms ccp lattice and those of element X occupy $2/3^{\text{rd}}$ of tetrahedral voids. What is the formula of the compound?

No. of Y atoms per unit cell in ccp lattice = 4

No. of tetrahedral voids = $2 * 4 = 8$

No. of tetrahedral voids occupied by X = $2/3 * 8 = 16/3$

Therefore formula of the compound = $X_{16/3} Y_4$

$$= X_{16} Y_{12}$$

$$= X_4 Y_3$$

HOTS Short Answer:

1. How many lattice points are there in one unit cell of the following lattices?
 - FCC
 - BCC
 - SCC
2. A cubic solid is made of two elements X and Y. Atom Y are at the corners of the cube and X at the body centers. What is the formula of the compound?
3. Silver forms ccp lattice and X-ray studies of its crystal show that the edge length of its unit cell is 408.6 pm. Calculate the density of silver (Atomic wt = 107.9u).
4. A cubic solid is made up of two elements P and Q. Atoms of the Q are present at the corners of the cube and atoms of P at the body centre. What is the formula of the compound? What are the co-ordination number of P and Q.
5. What happens when:-
 - CsCl crystal is heated
 - Pressure is applied on NaCl crystal.

Short Answers (3 marks):

1. The density of chromium is 7.2 g cm^{-3} . If the unit cell is a cubic with length of 289pm, determine the type of unit cell (Atomic mass of Cr = 52 u and $N_A = 6.022 * 10^{23} \text{ atoms mol}^{-1}$).

$$d = \frac{Z * M}{a^3}$$

$$a^3 \cdot N_A$$

$$Z = ? , a = 289 \text{ pm} = 289 \cdot 10^{-10} \text{ cm}, M = 52 \text{ g mol}^{-1}, d = 7.2 \text{ g cm}^{-3}$$

$$Z = \frac{d \cdot a^3 \cdot N_A}{M} = \frac{7.2 (\text{g cm}^{-3}) \cdot [289 \cdot 10^{-10} \text{ cm}]^3 \cdot 6.022 \cdot 10^{23} (\text{atom mol}^{-1})}{52 \text{ g mol}^{-1}}$$

M

52 g mol⁻¹

2. An element crystallizes in FCC structure; 200 g of this element has $4.12 \cdot 10^{24}$ atoms. If the density of A is 7.2 g cm^{-3} , calculate the edge length of unit cell.
3. Niobium crystallizes in bcc structure. If its density is 8.55 cm^{-3} , calculate atomic radius of [At. Mass of Niobium = 92.9u, $N_A = 6.022 \cdot 10^{23} \text{ atoms mol}^{-1}$].
4. If radius of octahedral void is r and radius of atom in close packing is R, derive the relationship between r and R.
5. Non stoichiometric cuprous oxide can be prepared in the laboratory. In this oxide, copper to oxygen ratio is slightly less than 2:1 can u account for the fact that the substance is a p-type semiconductor?
6. The unit cell of an element of atomic mass 50u has edge length 290pm. Calculate its density the element has bcc structure ($N_A 6.02 \cdot 10^{23} \text{ atoms mol}^{-1}$).
7. Calculate the density of silver which crystallizes in face centered cubic form. The distance between nearest metal atoms is 287pm (Ag= $107.87 \text{ g mol}^{-1}$, $N_A = 6.022 \cdot 10^{23}$).
8. What is the distance between Na^+ and Cl^- ions in NaCl crystal if its density 2.165 g cm^{-3} . NaCl crystallizes in FCC lattice.
9. Analysis shows that Nickel oxide has $\text{Ni}_{0.98} \text{O}_{1.00}$ what fractions of nickel exist as Ni^{2+} ions and Ni^{3+} ions?
10. Find the type of lattice for cube having edge length of 400pm, atomic wt. = 60 and density = 6.25 g/cc .

HOTS Short Answer:

1. Aluminium crystallizes in cubic closed pack structure. Its metallic radius is 125 pm
 - What is the length of the side of the unit cell?
 - How many unit cell are there in 100 cm^3 of Aluminium.
2. Classify the following as either p-type or n-type semiconductors.
 - Ge doped with In
 - B doped with Si

3. Zinc oxide is white but it turns yellow on heating. Explain.

Long Answer(5 Marks):

1. It is face centered cubic lattice A metal has cubic lattice. Edge length of lattice cell is 2Å . The density of metal is 2.4g cm^{-3} . How many units cell are present in 200g of metal.
2. A metal crystallizes as face centered cubic lattice with edge length of 450pm. Molar mass of metal is 50g mol^{-1} . The density of metal is?
3. A compound forms hexagonal close packed structure. What is the total number of voids in 0.5 mol of it? How many of these are tetrahedral voids?
4. Copper Crystallizes into FCC lattice with edge length $3.61 \times 10^{-8}\text{ cm}$. Show that calculated density is in agreement with measured value of 8.92g/cc .
5. Niobium crystallizes in bcc structure with density 8.55g/cc , Calculate atomic radius using atomic mass i.e. 93u.

HOTS Long Answer:

1. The compound CuCl has Fu structure like ZnS, its density is 3.4g cm^{-3} . What is the length of the edge of unit cell?

Hint: $d = \frac{Z \times M}{a^3 \times N_A}$

$$a^3 = \frac{4 \times 99}{3.4 \times 6.022 \times 10^{23}}$$

$$a^3 = 193.4 \times 10^{-24}\text{ cm}^3$$

$$a = 5.78 \times 10^{-8}\text{ cm}$$

2. If NaCl is dropped with $10^{-3}\text{ mol\% SrCl}_2$. What is the concentration of cation valancies?

3. If the radius of the octahedral void is r and the radius of the atom in the close packing is R . derive relationship between r and R .

4. The edge length of the unit cell of metal having molecular weight 75g/mol is Å which crystallizes into cubic lattice. If the density is 2g/cm^3 then find the radius of metal atom ($N_A = 6.022 \times 10^{23}$)
5. The density of K Br. Is 2.75 gm cm^{-3} . the length of edge of the unit cell is 654 pm. Predict the type of cubic lattice to which unit cell of KBr belongs.
 $N_A = 6.023 \times 10^{23}$; at mass of K=39: Br. = 80
Ans. Calculate value of $z = 4$ so it has fcc lattice

6. CsCl has bcc arrangement and its unit cell edge length is 400 pm . calculate the interionic distance of CsCl. Ans. 34604 pm
7. The radius of an Iron atom is 1.42 \AA . It has rock salt structure. Calculate density of unit cell. Ans. 5.74 g cm^{-3}
8. What is the distance between Na^+ and Cl^- in a NaCl crystal if its density is 2.165 g cm^{-3} NaCl crystalline in the fcc lattice. Ans. 281 PM
9. Copper crystalline with fcc unit cell. If the radius of copper atom is 127.8 pm. Calculate the density of copper metal. At. Mass of Cu=63.55u $N_A = 6.02 \times 10^{23}$ Ans. $a = 2\sqrt{2} \cdot r$, $a^3 = 4.723 \times 10^{-23}$, $d = 8.95 \text{ g cm}^{-3}$

KRISHNA
PUBLIC SCHOOL

Solution

KEY CONCEPTS

Solution is the homogeneous mixture of two or more substances in which the components are uniformly distributed into each other. The substances which make the solution are called components. Most of the solutions are binary i.e., consists of two components out of which one is solute and other is solvent. Ternary solution consists of three components

Solute - The component of solution which is present in smaller quantity.

Solvent - The component of solution present in larger quantity or whose physical state is same as the physical state of resulting solution.

Types of solutions: Based on physical state of components solutions can be divided into 9 types.

Solubility - The amount of solute which can be dissolved in 100gm of solvent at particular temp. to make saturated solution.

Solid solutions are of 2 types -

1. Substitutional solid solution e.g. Brass (Components have almost similar size)
2. Interstitial solid solution e.g. steel (smaller component occupies the interstitial voids)

Expression of concentration of solution

1. **Mass percentage** = amount of solute present in 100gm solution.

$$\text{Percentage} = \frac{\text{mass of solute}(W_B)}{\text{mass of solution}(W_A + W_B)} \times 100$$

For liquid solutions percentage by volume is expressed as = $\frac{\text{Volume of solute}(V_B)}{\text{volume of solution}(V_A + V_B)} \times 100$

2. **Mole fraction** it is the ratio of no. of one component to the total no. of moles of all components. It is expressed as 'x'. For two component system made of A and B, $X_A = \frac{n_A}{n_A + n_B}$, $X_B = \frac{n_B}{n_A + n_B}$, Sum of all the components is 1 ; $X_A + X_B = 1$

3. **Molarity (M)** = $\frac{\text{no. of moles of solute}}{\text{volume of solution}(L)}$

It decreases with increase in temperature as volume of solution increases with temperature.

4. **Molality (m)** = $\frac{\text{No. of moles of solute}}{\text{Mass of solvent}(in kg)}$

No effect of change of temperature on molality as it is mass to mass ratio.

5. **Normality (N)** = $\frac{\text{no. of gram equivalent of solute}}{\text{volume of solution}(L)}$

It changes with changes temperature.

6. **Parts per million (ppm)** concentration of very dilute solution is expressed in ppm.

$$\text{Ppm} = \frac{W_B}{W_B + W_A} \times 10^6$$

Vapor pressure – It is defined as the pressure exerted by the vapour of liquid over the liquid over the liquid in equilibrium with liquid at particular temperature vapour pressure of liquid depends upon nature of liquid and temperature.

Roult's Law –

1. For the solution containing non-volatile solute the vapor pressure of the solution is directly proportional to the mole fraction of solvent at particular temperature

$$P_A \propto X_A$$

$$P_A = P_A^0 \cdot X_A$$

2. For the solution consisting of two miscible and volatile liquids the partial vapor pressure of each component is directly proportional to its own mole fraction in the solution at particular temperature.

$$P_A = P_A^0 \cdot X_A, \quad P_B = P_B^0 \cdot X_B$$

And total vapor pressure is equal to sum of partial pressure. $P_{\text{total}} = P_A + P_B$

Ideal solution – The solution which obeys Roult's law under all conditions of temperature and concentration and during the preparation of which there is no change in enthalpy and volume on mixing the component.

Conditions –

$$P_A = P_A^0 \cdot X_A,$$

$$P_B = P_B^0 \cdot X_B$$

$$\Delta H_{\text{mix}} = 0,$$

$$\Delta V_{\text{mix}} = 0$$

This is only possible if A-B interaction is same as A-A and B-B interaction nearly ideal solution are –

1. Benzene and Toluene
2. Chlorobenzene and Bromobenzene

Very dilute solutions exhibit ideal behavior to greater extent.

Non-ideal solution –

$$(a) P_A \neq P_A^0 \cdot X_A$$

$$(b) P_B \neq P_B^0 \cdot X_B$$

$$(b) \Delta H_{\text{mix}} \neq 0$$

$$(d) \Delta V_{\text{mix}} \neq 0$$

For non-ideal solution the A-B interaction is different from A-A and B-B interactions

- i. For solution showing positive deviation

$$P_A > P_A^0, P_B > P_B^0 \cdot X_B$$

$$\Delta H_{\text{mix}} = \text{positive}, \quad \Delta V_{\text{mix}} = \text{positive} \quad (\text{A-B interaction is weaker than A-A and B-B})$$

E.g. alcohol and water

ii. For the solution showing negative deviation

$$P_A < P_A^0 \cdot X_A, \quad P_B < P_B^0 \cdot X_B$$

$$\Delta H_{\text{mix}} = \text{negative}, \quad \Delta V_{\text{mix}} = \text{negative}'$$

A-B interaction is stronger than A-A and B-B interactions

E.g. Chloroform, acetone, HCl and water

What is Azeotrope? – The mixture of liquids at particular composition which has constant boiling point which behaves like a pure liquid and cannot be separated by simple distillation. Azeotropes are of two types:

- (a) minimum boiling Azeotrope (mixture which shows +ve deviations) ex. alcohol and water
- (b) maximum boiling Azeotrope (which shows –ve deviations) ex. acetone and chloroform

Colligative Properties - Properties of ideal solution which depends upon no. of particles of solute but independent of the nature of particle are called colligative property

Relative lowering in vapour pressure:

$$\frac{(P_A^0 - P_A)}{P_A^0} = X_B$$

Determination of molar mass of solute

$$M_B = (W_A \times M_A \times P_A^0) / W_B \times (P_A^0 - P_A)$$

Elevator in Boiling Point

$$\Delta T_B = K_b \cdot m$$

$$\text{Where } \Delta T_B = T'_B - T_B^0$$

K_b = molal elevator constant

m = molality

$$M_B = (K_b \times 1000 \times W_B) / \Delta T_B \times W_A$$

Depression in Freezing Point:

$$\Delta T_f = k_f \cdot m$$

Where $\Delta T_f = T_f - T'_f$; m = molality

K_f = molal depression constant

unit = $\text{k} \cdot \text{kgmol}^{-1}$

Osmotic Pressure

The hydrostatic pressure which is developed on solution side due movement of solvent particles from lower concentration to higher concentration through semipermeable membrane denoted as π and it is expressed as

$$\pi = \frac{n}{V} RT$$

V

$$\pi = CRT$$

n = No. of moles; v = volume of solution (L)

R = $0.0821 \text{ Latmmol}^{-1}$; T = temperature in kelvin.

Isotonic solutions have same osmotic pressure and same concentration.

Hypertonic solutions have higher osmotic pressure and hypotonic solutions have lower osmotic pressure.

0.91% solutions have sodium chloride solution RBC swells up or burst.

ARISTARNA
PUBLIC SCHOOL

Q1- What do you mean by Henry's Law? The Henry's Law constant for oxygen dissolved in water is 4.34×10^4 atm at 25° C. If the partial pressure of oxygen in air is 0.2 atm, under atmospheric pressure conditions. Calculate the concentration in moles per Litre of dissolved oxygen in water in equilibrium with water air at 25° C.

Ans: Partial pressure of the gas is directly proportional to its mole fraction in solution at particular temperature.

$$P_A \propto X_A ; K_H = \text{Henry's Law of constant}$$

$$P_A = K_H \times A$$

$$K_H = 4.34 \times 10^4 \text{ atm}$$

$$P_{O_2} = 0.2 \text{ atm}$$

$$X_{O_2} = P_{O_2} / K_H = 0.2 / 4.34 \times 10^4 = 4.6 \times 10^{-6}$$

If we assume 1L solution = 1L water

$$n_{\text{water}} = 1000/18 = 55.5$$

$$X_{O_2} = n_{O_2} / (n_{O_2} + n_{H_2O}) \approx n_{O_2} / n_{H_2O}$$

$$n_{O_2} = 4.6 \times 10^{-6} \times 55.5 = 2.55 \times 10^{-4} \text{ mol}$$

$$M = 2.55 \times 10^{-4} \text{ M}$$

Q.2. What is Vant Hoff factor?

Ans. It is the ratio of normal molecular mass to observed molecular mass . It is denoted as 'i'

$$i = \text{normal m.m} / \text{observed m.m}$$

$$= \text{no. of particles after association or dissociation} / \text{no. of particles before}$$

Q.3. What is the Vant Hoff factor in $K_4[Fe(CN)_6]$ and $BaCl_2$?

Ans 5 and 3

Q.4. Why the molecular mass becomes abnormal?

Ans. Due to association or dissociation of solute in given solvent .

Q.5. Define molarity, how it is related with normality ?

Ans. $N = M \times \text{Basicity or acidity.}$

Q.6. How molarity is related with percentage and density of solution ?

Ans. $M = P \times d \times 10 / M.M$

Q.7. What role does the molecular interaction play in the solution of alcohol and water?

Ans. Positive deviation from ideal behavior .

Q.8. What is Vant Hoff factor , how is it related with

a. degree of dissociation b. degree of association

Ans. a. $\alpha = i - 1/n - 1$ b. $\alpha = i - 1 / 1/n - 1$

Q.9. Why NaCl is used to clear snow from roads ?

Ans. It lowers f.p of water

Q10. why the boiling point of solution is higher than pure liquid

Ans. Due to lowering in v.p

HOTS

Q1. Out of 1M and 1m aqueous solution which is more concentrated

Ans. 1M as density of water is 1gm/ml

Q2. Henry law constant for two gases are 21.5 and 49.5 atm ,which gas is more soluble .

Ans. KH is inversely proportional to solubility .

Q.3. Define azeotrope , give an example of maximum boiling azeotrope.

Q.4. Calculate the volume of 75% of H_2SO_4 by weight ($d=1.8 \text{ gm/ml}$) required to prepare 1L of 0.2M solution

Hint: $M_1 = P \times d \times 10 / 98$

$$M_1 V_1 = M_2 V_2$$

14.5ml

Q.5. Why water cannot be completely separated from aqueous solution of ethyl alcohol?

Ans. Due to formation of Azeotrope at (95.4%)

SHORT ANSWERS (2 MARKS)

Q.1. How many grams of KCl should be added to 1kg of water to lower its freezing point to -8.0°C ($k_f = 1.86 \text{ K kg /mol}$)

Ans. Since KCl dissociate in water completely $L=2$

$$\Delta T_f = i k_f \times m \quad ; m = \Delta T_f / i k_f$$

$$m = 8 / 2 \times 1.86 = 2.15 \text{ mol/kg.}$$

$$\text{Grams of KCl} = 2.15 \times 74.5 = 160.2 \text{ g/kg.}$$

Q.2. With the help of diagram: show the elevator in boiling point colligative properties ?

Q.3. what do you mean by colligative properties, which colligative property is used to determine m.m of polymer and why?

Q.4. Define reverse osmosis, write its one use.

Ans. Desalination of water.

Q.5. Why does an azeotropic mixture distills without any change in composition.

Hint: It has same composition of components in liquid and vapour phase.

Q.6. Under what condition Vant Hoff's factor is

- a. equal to 1 b. less than 1 c. more than 1

Q.7. If the density of some lake water is 1.25 gm /ml and contains 92 gm of Na^+ ions per kg of water. Calculate the molality of Na^+ ion in the lake .

Ans. $n = 92/23 = 4$

$$m = 4/1 = 4 \text{ m}$$

Q.8. An aqueous solution of 2% non-volatile exerts a pressure of 1.004 Bar at the normal boiling point of the solvent . What is the molar mass of the solute .

Hint: $P_A^0 - P_A / P_A^0 = w_B \times m_A / m_B \times w_A$

$$1.013 - 1.004 / 1.013 = 2 \times 18 / m_B \times 98$$

$$m_B = 41.35 \text{ gm/mol}$$

Q.9. Why is it advised to add ethylene glycol to water in a car radiator in hill station?

Hint: Anti- freeze.

Q.10. what do you mean by hypertonic solution, what happens when RBC is kept in 0.91% solution of sodium chloride?

Q 11. (a). define the following terms.

1. Mole fraction
2. Ideal solutions

(b) 15 g of an unknown molecular material is dissolved in 450 g of water. The resulting solution freezes at -0.34°C . what is the molar mass of material? K_f for water = $1.86 \text{ K Kg mol}^{-1}$.

Ans. 182.35 g/mol

Q 12.(a) explain the following :

1. Henry's law about dissolution of a gas in a liquid .
2. Boiling point elevation constant for a solvent

(b) a solution of glycerol ($\text{C}_3\text{H}_8\text{O}_3$) in water was prepared by dissolving some glycerol in 500 g of water. The solution has a boiling point of 100.42°C . what mass of glycerol was dissolved to make this solution?

K_b for water = $0.512 \text{ K Kg mol}^{-1}$

(hint: $\Delta t_b = \frac{b \cdot w_b \cdot 1000}{M_b \cdot W_a}$)

Ans. 37.73 gm

Q 13. 2 g of benzoic acid ($\text{C}_6\text{H}_5\text{COOH}$) dissolved in 25 g of benzene shows a depression in freezing point equal to 1.62 K . K_f for benzene is $4.9 \text{ K Kg mol}^{-1}$. What is the percentage association of acid if it forms dimer in solution. Ans. 99.2%

Q14. Osmotic pressure of a 0.0103 molar solution of an electrolyte is found to be 0.70 atm at 27°C . calculate Vant Hoff factor. ($R=0.082 \text{ L atm mol}^{-1} \text{ K}^{-1}$) Ans. 2.76

UNIT-3

ELECTROCHEMISTRY CONCEPTS

Electrochemistry may be defined as the branch of chemistry which deals with the quantitative study of interrelation ship between chemical energy and electrical energy and inter-conversion of one form into another. relationships between electrical energy taking place in redox reactions.

A cell is of two types:-

- I. Galvanic Cell
- II. Electrolytic cell.

In Galvanic cell the chemical energy of a spontaneous redox reaction is converted into electrical work.

In Electrolytic cell electrical energy is used to carry out a non-spontaneous redox reaction.

The Standard Electrode Potential for any electrode dipped in an appropriate solution is defined with respect to standard electrode potential of hydrogen electrode taken as zero. The standard potential of the cell can be obtained by taking the difference of the standard potentials of cathode and anode.

$$E^0_{\text{cell}} = E^0_{\text{cathode}} - E^0_{\text{anode}}$$

The standard potential of the cells are related of standard Gibbs energy.

$$\Delta_r G = -nFE^0_{\text{cell}}$$

The standard potential of the cells is related to equilibrium constant.

$$\Delta_r G = -RT \ln K$$

Concentration dependence of the potentials of the electrodes and the cells are given by Nernst equation.

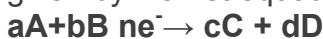

Nernst equation can be written as

$$E_{\text{cell}} = E^0_{\text{cell}} - \frac{RT}{nF} \ln \frac{[C]^c [D]^d}{[A]^a [B]^b}$$

The conductivity, K of an electrolytic solution depends on the concentration of the electrolyte, nature of solvent and temperature.

Molar Conductivity, Δ_m , is defined by K/C where C is the concentration in Mol L^{-1}

$$\Delta_m = \frac{k \times 1000}{m}$$

m

the unit of molar conductivity is $\Omega^{-1} \text{ cm}^2 \text{ mol}^{-1}$. Conductivity decrease but molar conductivity increases with decrease in concentration. It increases slowly with decrease in concentration for strong electrolyte while the increase is very dilute solutions.

Kohlrausch law of independent migration of ions. The law states that limiting conductivity of an electrolyte can be represented as the sum of the individual contribution to the anion and cation of the electrolyte.

Faraday's laws of Electrolysis

- I. The amount of chemical reaction which occurs at any electrode during electrolysis by a current is proportional to the quantity of electricity passed through the electrolyte.
- II. The amount of different substances liberated by the same quantity of electricity passing through the electrolytic solution is proportional to their chemical equivalent weights.

Batteries and full cells are very useful forms of galvanic cells
There are mainly two types of batteries.

Corrosion of metals is an electrochemical phenomenon

In corrosion metal is oxidized by loss of electrons to oxygen and formation of oxides.

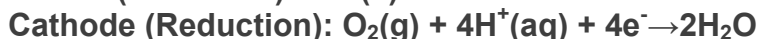

Atmospheric Oxidation:



QUESTION CARRING 1 MARK

1. What is the effect of temperature on molar conductivity?

Ans. Molar conductivity of an electrolyte increases with increase in temperature.

2. Why is it not possible to measure single electrode potential?

Ans. (It is not possible to measure single electrode potential because the half cell containing single electrode cannot exist independently, as charge cannot flow on its own in a single electrode.)

3. Name the factor on which emf of a cell depends:-

Ans. Emf of a cell depends on following factor-

- a. Nature of reactants.
- b. Concentration of solution in two half cells.
- c. Temperature

- d. Pressure of gas.
4. What are the units of molar conductivity?
($\text{cm}^2 \text{ohm}^{-1} \text{mol}^{-1}$ or $\text{Scm}^2\text{mol}^{-1}$)
5. Write Nernst equation –
For the general cell reaction
 $aA+bB \rightarrow cC+dD$

Ans.
$$E_{\text{cell}} = E^{\circ}_{\text{cell}} - \frac{RT}{nF} \ln \frac{[C]^c [D]^d}{[A]^a [B]^b}$$

6. What is the EMF of the cell when the cell reaction attains equilibrium?
Ans. Zero

7. What is the electrolyte used in a dry cell?
Ans. A paste of NH_4Cl , MnO_2 and C

8. How is cell constant calculated from conductance values?
Ans. Cell constant = specific conductance / observed conductance.

9. What flows in the internal circuit of a galvanic cell.
Ans. Ions

10. Define electrochemical series.
Ans. The arrangement of various electrodes in the decreasing or increasing order of their standard reduction potentials is called electrochemical series.

QUESTIONS CARRYING TWO MARKS

1. How can you increase the reduction potential of an electrode.?
For the reaction



Ans. Nernst equation is:

$$E_{M^{n+}/M} = E^{\circ}_{M^{n+}/M} - \frac{2.303RT \log 1}{nF [M^{n+}]}$$

$E_{M^{n+}/M}$ can be increased by

- increase in concentration of M^{n+} ions in solution
- by increasing the temperature.

2. Calculate emf of the following cell at 298K

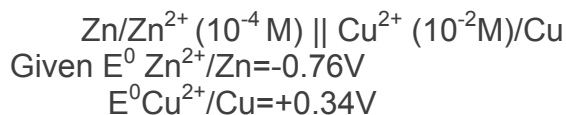

Ans. Cell reaction is as follows.

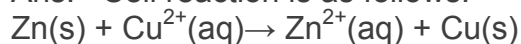

$N=2$

$T=298 \text{ K}$

$$E_{\text{cell}} = (E^{\circ} \text{Cu}^{2+}/\text{Cu} - E^{\circ} \text{Zn}^{2+}/\text{Zn}) - 0.0591 \text{ V} \log \frac{[\text{Zn}^{2+}(\text{aq})]}{[\text{Cu}^{2+}(\text{aq})]}$$

$$= 0.34 \text{ V} - (-0.76) - 0.02955 \text{ V} \log \frac{10^{-4}}{10^{-2}}$$

$$= 1.10 \text{ V} - 0.02955 \text{ V} \log 10^{-2}$$

$$= 1.10 \text{ V} + 2 \times 0.02955 \text{ V}$$

$$= 1.10 \text{ V} + 0.0591 \text{ V}$$

$$= 1.1591 \text{ V}$$

Q 3. Electrolysis of KBr(aq) gives Br_2 at anode but KF(aq) does not give F_2 . Give reason.

Ans. Oxidation takes place at anode. Now higher the oxidation Potential, easier to oxidize. Oxidation potential of Br^- , H_2O , F^- are in the following order.

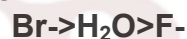

Therefore in aq. Solution of KBr . Br^- ions are oxidized to Br_2 in preference to H_2O . On the other hand, in aq. Solution of KF , H_2O is oxidized in preference to F^- . Thus in this case oxidation of H_2O at anode gives O_2 and no F_2 is produced.

3. What happens when a piece of copper is added to (a) an aq solution of FeSO_4 (b) an Aq solution of FeCl_3 ?

a. Nothing will happen when the piece of copper is added to FeSO_4 because reduction potential $E^{\circ} \text{Cu}^{2+}/\text{Cu}$ (0.34) is more than the reduction potential $E^{\circ}(\text{Fe}^{2+}/\text{Fe})$ (0.44V).

b. Copper will dissolve in an aq solution of FeCl_3 because reduction potential $E^{\circ} \text{Fe}^{3+}/\text{Fe}^{2+}$ (0.77V) is more than the reduction potential of $E^{\circ} \text{Cu}^{2+}/\text{Cu}$ (0.34)

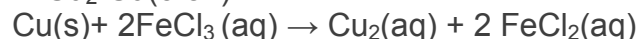

4. Define corrosion. Write chemical formula of rust.

Corrosion is a process of determination of metal as a result of its reaction with air and water, surrounding it. It is due to formulation of sulphides, oxides, carbonates, hydroxides, etc.

Formula of rust- $\text{Fe}_2\text{O} \cdot \text{XH}_2\text{O}$

5. Write short notes on reduction and oxidation potentials.

6. How are standard electrode potentials measured?

7. What is cell constant? How it is determined?

8. what is conductivity water

9. Why it is necessary to platinize the electrodes of a conductivity cell before it is used for conductance measurement?
10. Why mercury cell gives the constant voltage.
11. What is fuel cell, write reaction involved in H_2-O_2 fuel cell.

QUESTION CARRYING THREE MARKS

- | | |
|---|---|
| 1. Write any three differences between potential difference and e.m.f. | |
| E.M.F | POTENTIAL DIFFERENCE |
| 1. It is difference between electrode potential of two electrodes when no current is flowing through circuit. | 1. it is difference of potential between electrode in a closed circuit. |
| 2. it is the maximum voltage obtained From a cell. | 2. it is less than maximum voltage Obtained from a cell. |
| 3. it is responsible for steady flow of Current. | 3. it is not responsible for steady Flow of current. |

2. Why an electrochemical cell stops working after sometime?
The reduction potential of an electrode depends upon the concentration of solution with which it is in contact.

As the cell works, the concentration of reactants decrease. Then according to Le chatelier's principle it will shift the equilibrium in backward direction. On the other hand if the concentration is more on the reactant side then it will shift the equilibrium in forward direction. When cell works concentration in anodic compartment in cathodic compartment decrease and hence E^0 cathode will decrease. Now EMF of cell is

$$E^0_{\text{cell}} = E^0_{\text{cathode}} - E^0_{\text{anode}}$$

A decrease in E^0_{cathode} **and a corresponding increase in E^0 anode** will mean that EMF of the cell will decrease and will ultimately become zero i.e., cell stops working after some time.

3. for the standard cell

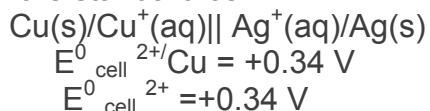

$$E^0 \text{ Ag}^+/\text{Ag} = +0.80 \text{ V}$$

- i. identify the cathode and the anode as the current is drawn from the cell.
- ii. Write the reaction taking place at the electrodes.
- iii. Calculate the standard cell potential.

Ans. 1. From the cell representation

Ag/Ag⁺ electrode is cathode and Cu/Cu⁺ electrode is anode .

1. At anode :

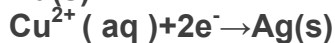

$$\begin{aligned} E^{\circ}_{\text{cell}} &= E^{\circ}_{\text{cathode}} - E^{\circ}_{\text{anode}} \\ &= E^{\circ}_{\text{Ag}^{+}/\text{Ag}} - E^{\circ}_{\text{Cu}^{2+}/\text{Cu}} \\ &= +0.80 \text{ V} - (+0.34\text{V}) \\ &= +0.80\text{V} - 0.34\text{V} \\ &= 0.46\text{V} \end{aligned}$$

2. Can we store copper sulphate in (i) Zinc vessel (ii) Silver vessel? Give reasons.

Given $E^{\circ}_{\text{Cu}^{2+}/\text{Cu}} = +0.34\text{V}$, $E^{\circ}_{\text{Zn}^{2+}/\text{Zn}} = -0.76\text{V}$, $E^{\circ}_{\text{Ag}^{+}/\text{Ag}} = +0.80\text{V}$

Ans. A metal having lower reduction potential can displace a metal having higher reduction potential from solution of its salt. of Cu²⁺ ($E^{\circ}_{\text{Cu}^{2+}/\text{Cu}}$)

i. Since standard reduction potential of Zn²⁺ ($E^{\circ}_{\text{Zn}^{2+}/\text{Zn}} = -0.76\text{V}$) is less than the standard reduction potential of Cu²⁺ ($E^{\circ}_{\text{Cu}^{2+}/\text{Cu}} = +0.34\text{V}$), Zn can displace copper from copper sulphate solution. Thus, CuSO₄ solution can be stored in silver vessel.

3. How many grams of chlorine can be produced by the electrolysis of matters NaCl with a current of 1.02 A for 15 min?

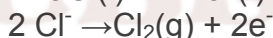
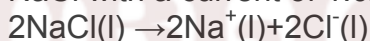

2 mole 1mol

$$Q = nf$$

$$Q = 2 \times 96500 \text{ C/mol} = 1.93 \times 10^5 \text{ C}$$

Quantity of electricity used = IT

$$= 1.02 \text{ A} \times (15 \times 60) \text{ sec}$$

$$= 900 \text{ C}$$

Molar mass of Cl₂ = $2 \times 35.5 = 71 \text{ gmol}^{-1}$ X 10⁵ C of charge produce chlorine = 71g

1.93 X 10⁵ C of charge produce chlorine = 71gm

900 C of charge produce chlorine $\frac{71 \times 900}{1.93 \times 10^5}$

$$= 0.331 \text{ gm}$$

4. What is understood by a normal hydrogen electrode? Give its significance.

5. Define electrode potential. Why absolute value of reduction potential of electrode cannot be determined?

6. Write the equation showing the effect of concentration on the electrode potential.

- Derive the relationship between Gibb's free energy change and the cell potential.
- How Nernst equation can be applied in the calculation of equilibrium constant of any cell reaction.?
- The cell reaction as written is spontaneous if the overall EMF of the cell is positive. Comment on this statement.

QUESTIONS CARRYING 5 MARKS

- Explain the term electrolysis. Discuss briefly the electrolysis of (i) molten NaCl (ii) aqueous sodium chloride solution (iii) molten lead bromide (iv) water.
- state and explain Faraday's laws of electrolysis. What is Electrochemical equivalent?
- What do you understand by 'electrolytic conduction'? what are the factors on which electrolyte conduction depends.? What is the effect of temperature on electrolytic conduction?
- How is electrolytic conductance measured experimentally?
- Describe normal hydrogen electrode and its applications.

HOT QUESTIONS

1 Mark questions:-

1. Why in a concentrated solution, a strong electrolyte shows deviations from Debye-Huckle- Onsagar equation?

Ans:- Because interionic forces of attractions are large.

2. What is the use of Platinum foil in the hydrogen electrode?

A: It is used for inflow and outflow of electrons.

3. Corrosion of motor cars is of greater problem in winter when salts are spread on roads to melt ice and snow. Why?

4. Is it safe to stir AgNO_3 solution with copper spoon? ($E^0_{\text{Ag}^+/\text{Ag}} = 0.80 \text{ Volt}$; $E^0_{\text{Cu}^+/\text{Cu}} = 0.34 \text{ Volt}$)

Ans: No it is not safe because reacts with AgNO_3 Solution (Emf will be positive.)

5. Why is it necessary to use salt bridge in A galvanic cell?

Ans: To complete inner circuit and to maintain electrical neutrality of the solution.

2 mark questions:-

1. Why is Li best reducing agent where as Fluorine is best oxidizing agent ?

2. Equilibrium constant is related to E^θ cell but not to E_{cell} . Explain.
3. Why sodium metal is not obtained at cathode when aq NaCl is electrolysed with Pt electrodes but obtained when molten NaCl is electrolysed ? 2
4. Zn rod weighing 25 g was kept in 100 mL of 1M copper sulphate solution. After certain time interval, the molarity of Cu^{2+} was found to be 0.8 M. What is the molarity of SO_4^{-2} in the resulting solution and what should be the mass of Zn rod after cleaning and drying ?
5. Which will have greater molar conductivity and why? Sol A. 1mol KCl dissolved in 200cc of the solution or Sol B. 1 mol KCl dissolved in 500cc of the solution.

3/ 5 mark questions:-

1. What do you mean by (i) negative standard electrode potential and (ii) positive standard electrode potential ?
2. Which cell is generally used in hearing aids? Name the material of the anode, cathode and the electrolyte. Write the reactions involved.
3. Iron does not rust even if Zinc coating is broken in galvanized iron pipe but rusting occurs much faster if tin coating over iron is broken. Explain.
4. ' Corrosion is an electrochemical phenomenon', explain.
5. Calculate the pH of following cell: Pt, $\text{H}_2/\text{H}_2\text{SO}_4$, if its electrode potential is 0.03V.
- 6 . A cell contains two hydrogen electrodes. The negative electrode is in contact with a solution of 10^{-5} M H^+ ions. The emf of the cell is 0.118 V at 298 K. Calculate the concentration of the H^+ ions at the positive electrode.
7. Crude copper containing Fe and Ag as contaminations was subjected to electro refining by using a current of 175 A for 6.434 min. The mass of anode was found to decrease by 22.260 g, while that of cathode was increased by 22.011 g. Estimate the % of copper, iron and silver in crude copper.
- 8 Zinc electrode is constituted at 298 K by placing Zn rod in 0.1 M aq solution of zinc sulphate which is 95 % dissociated at this concentration. What will be the electrode potential of the electrode given that $E^\theta_{\text{Zn}^{2+}/\text{Zn}} = - 0.76$ V. 3
9. At what pH will hydrogen electrode at 298 K show an electrode potential of -0.118 V, when Hydrogen gas is bubbled at 1 atm pressure ? 3
- 10 Electrolysis of the solution of MnSO_4 in aq sulphuric acid is a method for the preparation of MnO_2 as per the chemical reaction

$$\text{Mn}^{2+} + 2\text{H}_2\text{O} \rightarrow \text{MnO}_2 + 2\text{H}^+ + \text{H}_2$$
 Passing a current of 27 A for 24 Hrs gives 1 kg of MnO_2 . What is the current efficiency ? What are the reactions occurring at anode and cathode ?

Electrochemistry

Q 1. What do you mean by Kohlrausch's law: from the following molar conductivities at infinite dilution

$$\Delta m^\infty \text{Ba(OH)}_2 = 457.6 \text{ } \Omega^{-1} \text{ cm}^2 \text{ mol}^{-1}$$

$$\Delta m^\infty \text{Ba Cl}_2 = 240.6 \text{ } \Omega^{-1} \text{ cm}^2 \text{ mol}^{-1}$$

$$\Delta m^\infty \text{NH}_4\text{Cl} = 129.8 \text{ } \Omega^{-1} \text{ cm}^2 \text{ mol}^{-1}$$

Calculate Δm^∞ for NH_4OH

Ans. $238.3 \text{ } \Omega^{-1} \text{ cm}^2 \text{ mol}^{-1}$

Q2. Calculate the equilibrium constant for the reaction



If $E^0 \text{Cd}^{2+}/\text{Cd} = -.403 \text{ v}$

$E^0 \text{Zn}^{2+}/\text{Zn} = -0.763 \text{ v}$

Antilog 12.1827

Ans. 1.52×10^{12}

Q3. Predict the products of electrolyzing of the following

(a) a dil. solution of H_2SO_4 with Pt. electrode

(b). An aqueous solution of AgNO_3 with silver electrode

KRISHNA
PUBLIC SCHOOL

UNIT-4

CHEMICAL KINETICS

CONCEPT

Thermodynamics helps us to predict the feasibility of chemical reaction by using ΔG as parameter but it cannot tell everything about the rate of reaction. Rate of chemical reaction is studied in another branch of chemistry called Chemical Kinetics.

Chemical kinetics- The branch of physical chemistry which deals with the study of rate of reaction and their mechanism is called chemical kinetics.

Rate of chemical reaction- The change in concentration of any reactant or product per unit time is called rate of reaction.

TYPES OF RATE OF REACTION-

1. **Average rate of reaction-** The rate of reaction measured over the long time interval is called average rate of reaction.

$$\text{Avg rate } \Delta x/\Delta t = -\Delta[R]/\Delta t = +\Delta[p]/\Delta t$$

2. **Instantaneous rate of reaction-** The rate of reaction measured at a particular time is called instantaneous rate of reaction.

$$\text{Instantaneous rate } dx/dt = -d[R]/dt = +d[P]/dt$$

FACTORS AFFECTING RATE OF REACTION-

1. Concentration of reactant
2. Surface area
3. Temperature
4. Nature of reactant
5. Presence of catalyst
6. Radiation

RATE CONSTANT (k)- It is equal to the rate of reaction when molecular concentration of reactant is at unity.

RATE LAW- The rate of reaction is directly proportional to the product of concentration of reactant and each concentration is raised to some power which may or may not be equal to stereochemistry experimentally.

For a reaction

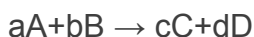

$$\text{Rate law} = k[A]^p[B]^q$$

Where powers P and Q are determined experimentally

MOLECULARITY – The total no. of reactants taking part in elementary chemical reaction is called molecularity.

ORDER OF REACTION- The sum of powers to which the concentrations terms are raised in a rate law expression is called order of reactions. For above case order = P+Q: orders of r^n is determined experimentally

HALF-LIFE PERIOD- The time during which the concentration of the reactant is reduced to half of its initial concentration is called half-life period.

ACTIVATION ENERGY- The minimum extra amount of energy absorbed by reactant molecules so that their energy becomes equal to the threshold energy is called activation energy.

Activation energy = Threshold energy – kinetic energy

TEMPERATURE COEFFICIENT- The ratio of rate constant at two temperatures having difference of 10^0C is called temperature coefficient.

Temperature coefficient = Rate constant at $T+10^0\text{C}$ /Rate constant at $T^0\text{C}$

Arrhenius Equation-

$$K = Ae^{-E_a/RT}$$

K-rate constant

A-Arrhenius energy

E_a-Activation energy

R- Rate constant

T-Temperature

$$\text{Log } K = \text{Log } A - \frac{E_a}{2.303RT}$$

Energy of activation can be evaluated as

$$1. \text{Log } [K_2/K_1] = \frac{E_a(1/T_1 - 1/T_2)}{2.303RT}$$

$$\text{Log } [K_2/K_1] = \frac{E_a(1/T_1 - 1/T_2)}{19.15}$$

1 MARKS QUESTION

1. The gas phase decomposition of acetaldehyde

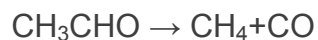

Follows the rate law.

What are the units of its rate constant.

Ans. $\text{Atm}^{-1/2}\text{sec}^{-1}$

2. State the order with respect to each reactant and overall reaction.

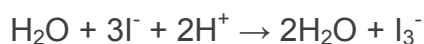

$$\text{Rate} = k[\text{H}_2\text{O}_2]^1[\text{I}^-]^1$$

Ans. Order of reaction = 1+1 = 2

3. Give one example of pseudo first order reaction.

Ans. Hydrolysis of an ester



4. The conversion of molecules X to Y follows the second order of kinetics. If concentration of X is increased 3 times, how will it affect the rate of formation of Y.

$$\begin{aligned}\text{Ans. Rate} &= k [\text{A}]^2 \\ &= k [3\text{A}]^2 \\ &= k [9\text{a}]^2\end{aligned}$$

The rate of formation will become nine times.

5. The rate law for a reaction is

$$\text{Rate} = K [\text{A}] [\text{B}]^{3/2}$$

Can the reaction be an elementary process? Explain.

Ans. No, an elementary process would have a rate law with orders equal to its molecularities and therefore must be in integral form.

6. What do you understand by 'rate of reaction'?
7. Name the factors on which the rate of a particular reaction depends.
8. Why rate of reaction does not remain constant throughout?
9. Define specific reaction rate or rate constant.

10. What is half-life period of a reaction?

2 MARKS QUESTION

1. The rate of a particular reaction quadruples when the temperature changes from 293K to 313K. Calculate activation energy.

Ans. $K_2/K_1 = 4$,

$$T_1 = 293\text{K} \quad T_2 = 313\text{K}$$

$$\log [K_2/K_1] = E_a [T_2 - T_1] / 19.15$$

Thus on calculating and substituting values we get.....

$$E_a = 52.86 \text{ KJ mol}^{-1}$$

2. If the decomposition of nitrogen oxide as

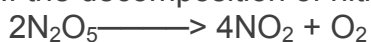

follows a first order kinetics.

(i) Calculate the rate constant for a 0.05 M solution if the instantaneous rate is $1.5 \times 10^{-6} \text{ mol/l/s}$?

Ans. Rate = $K [\text{N}_2\text{O}_5]$

$$K = \frac{\text{Rate}}{[\text{N}_2\text{O}_5]}$$

$$K = \frac{1.5 \times 10^{-6}}{0.05}$$

$$K = 3.0 \times 10^{-5}$$

ii) What concentration of N_2O_5 would give a rate of $2.45 \times 10^{-5} \text{ mol L}^{-1}\text{s}^{-1}$

$$\text{Rate} = 2.45 \times 10^{-5} \text{ mol L}^{-1}\text{s}^{-1}$$

$$[\text{N}_2\text{O}_5] = \frac{\text{Rate}}{K} = \frac{2.45 \times 10^{-5}}{3.0 \times 10^{-5}}$$

$$= 0.82 \text{ M}$$

3) Write the difference between order and molecularity of reaction.

Ans. ORDER

MOLECULARITY

It is the sum of the powers of concentration terms in the rate law expression.

It is the number of reacting species undergoing simultaneously Collision in a reaction.

It is determined experimentally

it is a theoretical concept

Order of reaction need not be a whole number

It is whole no. only

Order of reaction can be zero.

It can't be zero or fractional

4) Define Threshold energy and activation energy. How they are related?

Ans. Threshold Energy: It is the minimum amount of energy which the reactant molecules must possess for the effective collision in forming the products.

Activation Energy: It is the excess energy required by the reactants to undergo chemical reaction.

Activation energy = Threshold energy – Average kinetic energy of molecules.

5(a). Draw a schematic graph showing how the rate of a first order reaction changes in concentration of reactants.

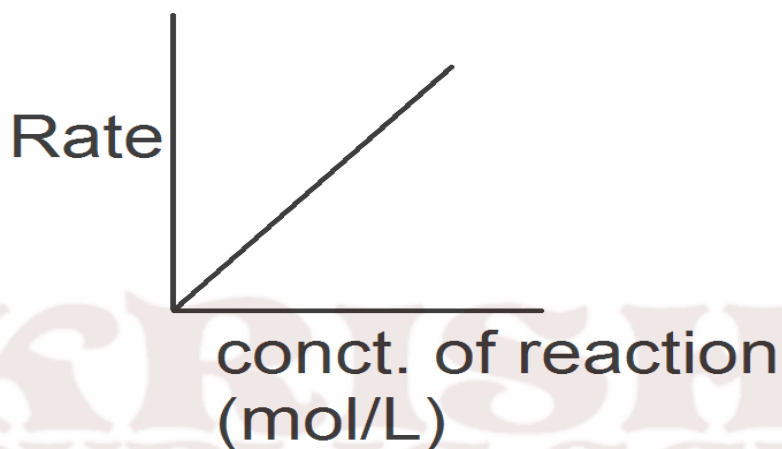

Variation of rate of first of first order reaction with concentration.

(b). rate of reaction is given by the equation

$$\text{Rate} = k [A] [B]$$

What are the units of rate constant for this reaction?

Ans. Rate = $k [A] [B]$

$$K = \frac{\text{mol L}^{-1} \text{s}^{-1}}{(\text{mol L}^{-1})^2 (\text{mol}^{-1})}$$
$$K = \text{mol}^{-2} \text{L}^2 \text{s}^{-1}$$

6. List the factors affecting the rate of reaction.

7. Explain with suitable example, how the molecularity of a reaction is different from the order of a reaction.

8. Define the term 'rate constant' of 'specific reaction rate'.
9. What are Pseudo unimolecular reactions? Explain with the help of a suitable example.
10. What is half life period? Derive and expression for half-life period in case of a first order reaction.

3 marks question

Q1. The rate constant for first order reaction is 60/s. How much time will it take to reduce the concentration of the reaction to 1/10 of its initial value.

Ans:-

$$t = \frac{2.303}{K} \log \frac{[R_0]}{[R]}$$

$$t = \frac{2.303}{60} \log \frac{[R_0]}{\frac{1}{10} [R]}$$

$$t = \frac{2.303}{60} \log 10$$

$$t = \frac{2.303}{60} = 3.38 \times 10^{-2} \text{s}^{-1}$$

2. The rate of most of reaction double when their temperature is raised from 298k to 308k. Calculate the activation energy of such a reaction.

Ans:-

$$\log \frac{K_2}{K_1} = \frac{E_a}{2.303 R} \left(\frac{1}{T_1} - \frac{1}{T_2} \right)$$

$$E_a = \frac{2.303 \times 8.314 \times 298 \times 308 \times 0.3010}{1000}$$

$$E_a = 52.89 \text{KJ/mol}$$

3. A first order reaction takes 69.3 min for 50% completion. Set up on equation for determining the time needed for 80% completion.

$$\text{Ans. } K = \frac{0.693}{T^{1/2}}$$

$$= 0.693/69.3 \text{min}$$

$$= 10^{-2} \text{min}^{-1}$$

$$T = \frac{2.303 \log [R_0]}{K [R]}$$

$$T = 2.303/10^{-2} \log 5$$

$$T = 160.9 \text{min}$$

4. Following reaction takes place in one step

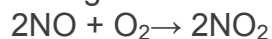

How will the rate of the reaction of the above reaction change if the volume of reaction vessel is diminished to 1/3 of its original volume? Will there be any change in the order of reaction with reduced volume?

Ans. $2\text{NO} + \text{O}_2 \rightarrow 2\text{NO}_2$

$$dx/dt = k[\text{NO}]^2[\text{O}_2]^1$$

[Since it is one step]

If the volume of reaction vessel is diminished to 1/3, conc. Of both NO and O₂ will become 3 time, the rate of reaction increased 27 times.

In the order of reaction with the reduced volume.

5. The decomposition of NH₃ on platinum surface is a zero order reaction.

What are the rate of production of N₂ and H₂.

If $k = 2.5 \times 10^{-4}$

Ans. $2\text{NH}_3 \rightarrow \text{N}_2 + 3\text{H}_2$

$$\frac{-1}{2} \frac{d[\text{NH}_3]}{dt} = \frac{d[\text{N}_2]}{dt} + \frac{1}{3} \frac{d[\text{H}_2]}{dt}$$

$$-\frac{d[\text{NH}_3]}{dt} = \text{rate} = k \times [\text{NH}_3]^0$$

$$= 2.5 \times 10^{-4} \text{ molL}^{-1}\text{sec}^{-1}$$

$$\frac{d[\text{N}_2]}{dt} = -\frac{1}{2} \frac{d[\text{NH}_3]}{dt}$$

$$= \frac{1}{2} \times 2.5 \times 10^{-4} \text{ molL}^{-1}\text{sec}^{-1}$$

$$d[\text{H}_2] = -\frac{3}{2} \frac{d[\text{NH}_3]}{dt} = \frac{3}{2} \times 2.5 \times 10^{-4}$$

$$= 3.75 \times 10^{-4} \text{ molL}^{-1}\text{sec}^{-1}$$

$$\text{Rate} = -\frac{d[\text{NH}_3]}{dt} = k \times [\text{NH}_3]^0$$

$$= 2.5 \times 10^{-4} \text{ molL}^{-1}\text{sec}^{-1}$$

$$\text{Rate of production of N}_2 = 2.5 \times 10^{-4} \text{ molL}^{-1}\text{sec}^{-1}$$

6. How is the rapid change in concentration of reactants/products monitored for fast reactions.

7. What are photochemical reactions? Give two examples,

8. What is the effect of temperature on the rate of reaction? Explain giving reasons.

9. Comment on free energy change of 'photochemical reactions'.

10. State the role of activated complex in a reaction and state its relation with activation energy.

QUESTIONS CARRYING 5 MARKS

1. What do you understand by the rate of a reaction? How it is expressed? How it is the rate of reaction determined?
2. What do you understand by order of a reaction? How does rate law differ from law of mass action? Give two example of each of the reactions of (i) zero order (ii) first order (iii) second order
3. Derive the equation for the rate constant for a first order reaction. What would be the units of the first order rate constant if the concentration is expressed in mole per litre and time in seconds.
4. Explain why the rate of reaction increases with increase in temperature.
5. Briefly explain the effect of temperature on the rate constant of a reaction.

HOTS

1. The half-life period of two samples are 0.1 and 0.4 seconds. Their initial Concentrations are 200 and 50 mol L⁻¹ respectively. What is the order of reaction?
2. What is the ratio of $t_{3/4} : t_{1/2}$ for a first order reaction ?
3. Higher molecularity reactions (viz. molecularity, 4 and above) are very rare. Why?
4. Consider the reaction $2A + B \xrightarrow{\quad} \text{Products}$

When concentration of B alone was doubled, half life time does not change. When conc. of A alone is doubled, the rate increases by two times. What is the unit of K and what is the order of the reaction?

5. For the reaction, the energy of activation is 75KJ / mol. When the energy of activation of a catalyst is lowered to 20KJ / mol. What is the effect of catalyst on the rate of reaction at 20⁰C.

6. The gas phase decomposition of CH₃OCH₃ follows first order of kinetics
 $\text{CH}_3\text{OCH}_3 \rightarrow \text{CH}_4(\text{g}) + \text{H}_2(\text{g}) + \text{CO}(\text{g})$
 The reaction is carried out at a constant volume of the container at 500⁰ C and has $t_{1/2} = 14.5\text{min}$.
 Initially only dimethyl ether is present at a pressure of 0.40 atm. What is the total pressure of the system after 12 min? Assume ideal behavior.

Q 7. See the graph and answer the following question

- 1). What is the order of r^n

2) what is the value of a and b

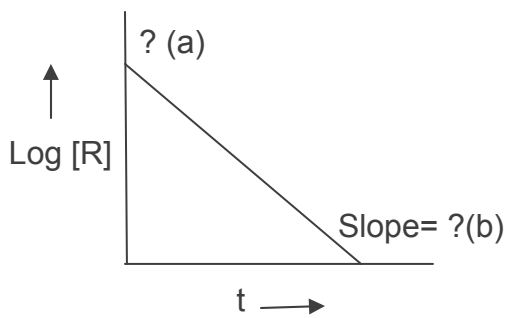

q 8. 1) what is the order of r^n

2) what is the value of slope and intercept

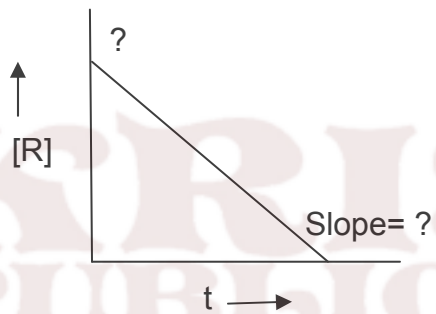

q 9.1). what is the value of slope

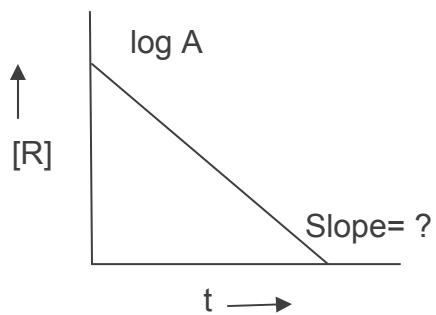

Chapter-5 SURFACE CHEMISTRY

The branch of the Chemistry which deals with the study of surface phenomena is called surface Chemistry.

POINTS TO BE REMEMBERED: ---

1. **Adsorption:** - The accumulation of molecules species at the surface rather in the bulk of a solid or liquid is termed adsorption.
2. **Desorption:**-Removal of adsorbate from the surface of adsorbent is known as Desorption.
3. **Sorption:**-When adsorption and absorption both takes place simultaneously.
4. **Type of adsorption:** - On the basis of interaction between adsorption and absorption, adsorbate are of two types:
 - (i) **Physical adsorption/physisorption:** - When weak vander waal interaction involve between adsorbate and adsorbent.
 - (ii) **Chemical adsorption/chemisorption:**-When chemical bonds form between adsorbate and adsorbent.
5. **Adsorption isotherm:**-The variation in the amount of gas adsorbed by the adsorbent with pressure at constant temperature can be expressed by means of a curve termed as adsorption isotherm.
6. **Application of adsorption:**-
 - (a) Removal of colouring matter from solution using animal charcoal.
 - (b)Chromatographic analysis is based on adsorption.
7. **Freundlich adsorption isotherm:**-It is a graph which shows relationship between the quantity of gas adsorbed by unit mass of solid adsorbent and pressure at a particular temperature.

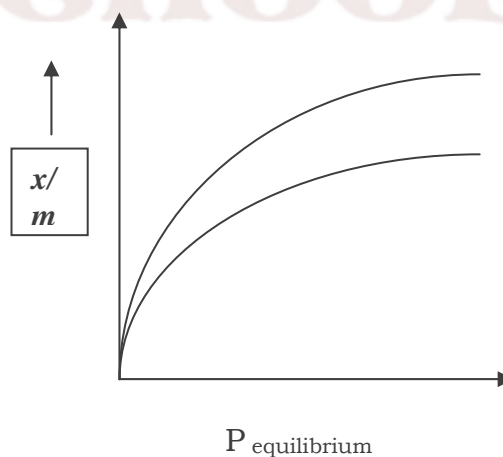
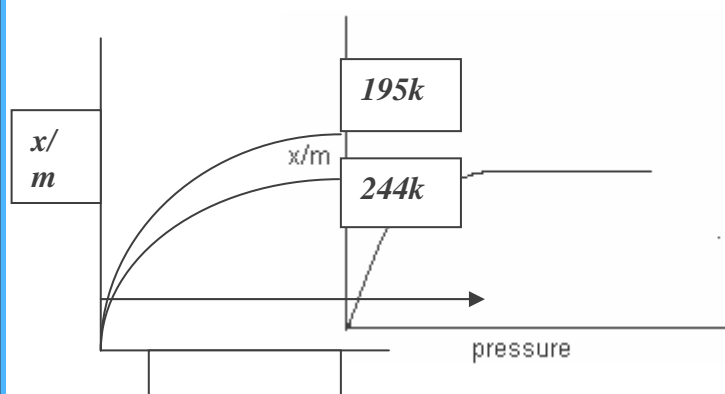

$$x/m = kp^{1/n}$$

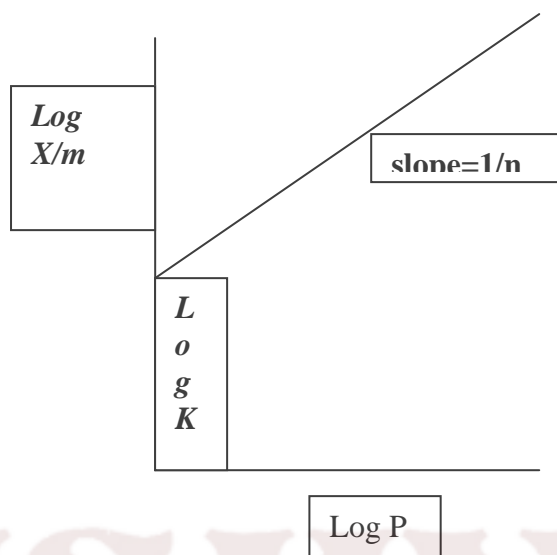

8. Factors affecting adsorption:-

- (i) Surface area: - Adsorption increases with increases of surface area of adsorbent.
- (ii) Nature of adsorbate:- Easily liquefiable gases are readily adsorbed.
- (iii) Temperature:- Low temperature is favorable for physical adsorption and High temperature for chemisorption.
- (iv) Pressure: - Pressure increases, adsorption increases.

9. CATALYSIS:- Substances which alter the rate of chemical reaction and themselves remain chemically and quantitatively unchanged after the reaction are known as catalyst and the phenomenon is known as catalysis.

10. PROMOTERS AND POISONS

Promoters are substance that enhance the activity of catalyst while poisons decrease the activity of catalyst.

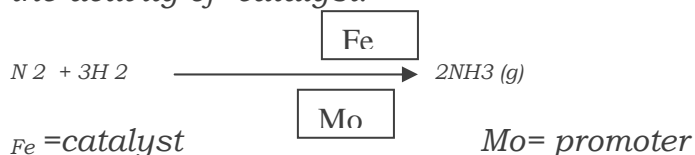

11. Homogenous catalyst – when reactants and catalyst are in same phase.



12. Heterogeneous catalyst – the catalytic process in which the reactants and catalyst are in different phase.



13. Adsorption theory of Heterogeneous catalysis – It explains the mechanism of heterogeneous catalyst.

The mechanism involves 5 steps:-

- a. Diffusion of reactants to the surface of catalyst.

- b. Adsorption of reactant molecules on the surface of catalyst.
- c. Chemical reaction on the catalyst surface through formation of an intermediate.
- d. Desorption of reaction product from the catalyst surface.
- e. Diffusion of reaction product away from the catalyst surface.

14. **IMPORTANT FEATURES OF SOLID CATALYST**

Activity - The activity of a catalyst depend on the strength of chemisorption. Catalytic activity increases from group 5 to group 11 elements of the periodic table.

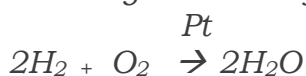

Selectivity - The selectivity of a catalyst is its ability to direct a reaction to yield a particular product.

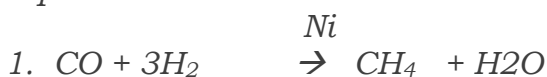

15. **SHAPE SELECTIVE CATALYSIS**

The catalytic reaction that depends upon the pure substance of the catalyst and the size of reactant and product molecules is called shape selective catalysis.

e.g. Zeolites are good shape selective catalyst.

16. **ENZYME CATALYSIS**

Enzymes are protein molecules of high molecular mass which catalyse the biochemical reaction.

e.g. Inversion of cane sugar by invertase enzyme.

17. **Characteristic of enzyme catalysis -**

- a. **Enzymes are specific to substrate.**
- b. **Enzymes are highly active under optimum temperature.**
- c. **Enzymes are specific to pH. e.g. Pepsin act in acidic medium**
- d. **Enzymes are inhibited by the presence of certain substance.**

Mechanism of enzyme catalysis -

1. Binding of enzyme to substrate to form an activated complex.



2. Decomposition of activated complex to form product.

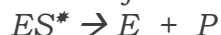

18. Colloid-a colloid is a heterogeneous system in which one substance is dispersed (dispersed phase) in another substance called dispersion medium and size of dispersed phase is from 1nm-1000 nm.

19. **TYPES OF COLLOIDS**

(1) On the basis of nature of interaction between dispersed phase and dispersion medium.

(a) Lyophobic colloid-solvent, hating colloid, these colloids can not be prepared by simply mixing of dispersed phase into dispersion medium.

e.g. metallic sols.

(b) Lyophobic colloid-solvent loving these colloids can be prepared by simply mixing of dispersion phase into dispersion medium.

e.g. Starch sol.

(2) On the basis of types of particles of the dispersed phase

(a) Multimolecular colloid-on dissolution, a large number of atoms or smaller molecules of a substance aggregate together to form species having size in colloidal range. The species thus formed are called Multimolecular colloids.

e.g. Sulphur sol.

(b) Macromolecular colloids -macromolecules are suitable solvent from solution in which size of the particles are in range of colloidal range.

e.g. starch sol.

(c) Associated colloids (micelles)-some substances in low concentration behaves as normal strong electrolyte but at higher concentration exhibit colloidal behavior due to formation of aggregates. The aggregated particles are called micelles and also known as associated colloids.

(3) **Kraft temperature**- Temp. above which formation of micelles takes places.

(4) **Critical micelle concentration (cmc)** - concentration above which micelle formation takes place is known as cmc.

(5) PREPERATION OF COLLOIDS

(a) **Chemical methods**- By double decomposition, oxidation reaction or hydrolysis

OXIDATION



HYDROLYSIS

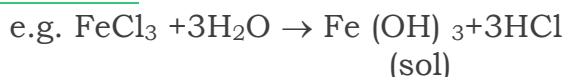

(b) **Bredig's arc method**- For preparation of metallic sol. It involves dispersion as well as condensation.

(c) **Peptization**- Process of converting a precipitate into colloidal sol. By shaking it with dispersion medium in the presence of a small amount of electrolyte.

(6) PURIFICATION OF COLLOIDAL SOLUTION :-

(a) **Dialysis**-it is a process of removing a dissolved substance from a colloidal solution by membrane.

(b) **Electro dialysis**-when dialysis is carried out with an electric field applied around the membrane.

(c) **Ultra filtration**- Use of special filters which are permeable to all ionic substances except colloidal particles.

(7) PROPERTIES OF COLLOIDAL SOLUTION:-

(1) They show colligative properties

(2) Brownian movement-zig-zag motion of colloidal particles

(3) Tyndall effect-scattering of light by colloidal particles by which path of beam becomes clearly visible. This effect is known as Tyndall effect.

1. Charge on colloidal particles – Colloidal particles which carry on electric charge and nature of charge is same on all particles.

2. Electrophoresis - Movement of Colloidal particles towards opposite electrode in presence of external electric field.

3. Coagulation – The process of setting of colloidal particles is called coagulation of the sol.

4. Hardy Schulze Law – Coagulating value of a coagulating ion is directly proportional to the charge on the ion.

Eg: $\text{Na}^+ < \text{Ca}^{++} < \text{Al}^{3+}$ for negatively charged sol.

$\text{Cl}^- < \text{CO}_3^{2-} < \text{PO}_4^{3-} < [\text{Fe}(\text{CN})_6]^{4-}$ for positive sol.

5. Emulsion – Liquid – liquid colloidal system is known as Emulsion.

There are two types of Emulsion.

a) O/W type - Oil dispersed in water. Eg: milk, vanishing cream.

b) W/O type – Water dispersed in oil. Eg: Butter & Cream.

6. Emulsifying Agent – The substance which stabilizes emulsion.

VERY SHORT ANSWER TYPE QUESTION

(1 marks)

1. What are the physical states of dispersed phase and dispersion medium of froth?

Ans - Dispersed phase is gas, dispersion medium is liquid.

2. What is the cause of Brownian movement among colloidal particles?

Ans - Due to collision between particles.

3. Arrange the solutions: True solution, colloidal solution, suspension in decreasing order of their particles size?

Ans – Suspension > colloidal > true solution.

4. Give an example of micelles system?

Ans – Sodium stearate ($C_{17}H_{35}COO^-Na^+$)

5. Why is it necessary to remove CO when ammonia is obtained by Haber's process?

Ans- CO acts as poison catalyst for Haber's process therefore it will lower the activity of solution therefore it is necessary to remove when NH_3 obtained by Haber's process.

6. How is adsorption of a gas related to its critical temperature?

Ans- Higher the critical temperature of the gas. Greater is the ease of liquefaction.

i.e. greater Vander walls forces of attraction and hence large adsorption will occur.

7. What is meant by Shape Selective Catalyst?

Ans – On the Shape Selective Catalyst, the rate depends upon pore size of the catalyst and the shape & size of the reactant and products molecules.

8. Of the physisorption & chemisorptions, which type of adsorption has higher enthalpy of adsorption?

Ans - chemisorptions.

9. Write down the Example of Positive Sol?

Ans – Ferric hydro-oxide sol.

10. Write down the Example of Negative Sol?

Ans – Arsenic sulphide.

SHORT ANSWER TYPE QUESTION

(2 marks)

1. Differentiate between physical & chemical adsorption?

Ans –

Physical adsorption	Chemical adsorption
a) Forces between adsorbate & adsorbent are weak Vander waal forces. b) Low heat of Adsorption.	a) Forces between adsorbate & adsorbent are strong chemical forces. b) High heat of Adsorption.

2. Differentiate between Lyophobic & Lyophilic colloids?

3. Ans –

Lyophilic colloids	Lyophobic colloids
a) These are easily formed by direct mixing. b) Particles of colloids are not easily visible even under ultra microscope. c) These are very stable.	a) These are easily formed by Special method. b) Particles of colloids are easily visible under ultra microscope. c) These are unstable.

4. Differentiate between multi molecular, macromolecular and associated colloids?

5. Ans:-

Multi molecular colloids	Macromolecular colloids	Associated colloids
a) They consist of	a) They consist of	a) Behave as colloidal

aggregates of atoms or molecules which generally have diameter less than 1nm. b) They are usually lyophobic	large molecules. b) They are hydrophilic.	size particles at higher conc. b) They have both lyophobic character & Lyophilic
--	--	---

6. What is difference between Sol. & Gel?

Ans – Both are colloidal solutions. Sol has solid as ‘dispersed phase & liquid as dispersion medium’. While ‘Gel’ has liquid as dispersed phase and solid as dispersion medium.

7. Action of Soap is due to Emulsification & Micelle formation? Comment.

Ans – soaps are sodium & potassium salts of higher fatty acids.

Eg: $C_{17}H_{35}COONa$ oil & Grease in dirt adhere firmly to clothing and is undisturbed by washing in tap water. Soap acts as an Emulsifying agent and brings the Greasy dirt into colloidal dispersion the hydrocarbon chain of soap molecule is soluble in oil or grease. It dissolves in grease and encapsulates. It to form micelle. The anionic ends of chain protrude from droplets and interact with water molecules, preventing coalescence of droplets.

SHORT ANSWER TYPE QUESTION

(3 marks)

8. Discuss the effect of pressure & temperature on the adsorption of gases on solids?

Ans – Effect of pressure on adsorption: - At constant temp the extent of adsorption of gas(x/m) in the solid increases with pressure. A graph between x/m and the pressure P of a gas at constant temp is called adsorption isotherm.

Freundlich adsorption isotherm -

i) At lower range of pressure, (x/m) is directly proportional to the applied pressure.

$$X/m \propto p^1$$

ii) At high pressure range, the extent of adsorption of a gas (x/m) is independent of the applied pressure i.e.

$$X/m \propto p^0$$

iii) At intermediate pressure range, the value of (x/m) is proportional to the fractional power of pressure i.e.

$$X/m \propto p^{1/n}$$

Where $1/n$ is fraction. Its value may be between 0 and 1

$$X/m = kp^{1/n}$$

$$\text{Log}(x/m) = \text{log } k + 1/n \text{ log } p$$

Effect of temp on Adsorption – Adsorption is generally temp. depended. Mostly adsorption processes are exothermic and hence, adsorption decreases with increasing temp. However for an endothermic adsorption process adsorption increases with increase in Temperature.

1. Explain What is observe when

- i) An electrolyte, NaCl is added to hydrate ferric oxide sol.
- ii) Electric current is passed through a colloidal sol.

iii) When a beam of light is passed through a colloidal sol.

Ans –(i) The positively charged colloidal particles of $\text{Fe}(\text{OH})_3$ get coagulated by the positively charged Cl^- ions provided by NaCl .

(ii) On passing direct current, colloidal particles move towards the positively charged electrode where they lose their charge and get coagulated.

(iii) Scattering of light by the colloidal particles takes place and the path of light becomes visible (Tyndall effect).

2. Describes some features of catalysis by Zeolites?

Ans – Features of catalysis by Zeolites:-

I) Zeolites are hydrated alumino silicates which have a three dimensional network structure containing water molecules in their pores.

II) To use them as catalysts, they heated so that water of hydration present in the pores is lost and the pores become vacant.

III) The size of pores varies from 260 to 740 pm. Thus, only those molecules can be adsorbed in these pores and catalyzed whose size is small enough to enter these pores. Hence, they act as molecular sieves or shape selective catalysts.

An important catalyst used in petroleum industries is zsm-5. It converts alcohols into petrol by first dehydrating them to form a mixture of hydrocarbons.

Alcohols $\xrightarrow[\text{Dehydration}]{\text{ZSm-5}}$ Hydrocarbons

3. Comment on the statement that “colloid is not a substance but state of a substance”?

Ans – The given statement is true. This is because the substance may exist as a colloid under certain conditions and as a crystalloid under certain other conditions. e.g: NaCl in water behaves as a crystalloid while in benzene, it behaves as a colloid (called associated colloid). It is the size of the particles which matters i.e. the state in which the substance exists. If the size of the particles lies in the range 1nm to 1000nm it is in the colloid state.

4. Write short notes on followings:-

- (a) Tyndall effect
- (b) Brownian Movement
- (c) Hardy Schulze Rule

Ans- (a) Tyndall effect-scattering of light by colloidal particles by which path of beam becomes clearly visible. This effect is known as Tyndall effect

(b) Brownian movement-zig-zag motion of colloidal particles.

(c) Hardy Schulze Law – Coagulating value of a coagulating ion is directly proportional to the charge on the ion.

e.g: $\text{Na}^+ < \text{Ca}^{++} < \text{Al}^{3+}$ for negatively charged sol.

$\text{Cl}^- < \text{CO}_3^{2-} < \text{PO}_4^{3-} < [\text{Fe}(\text{CN})_6]^{4-}$ for positive sol.

Chapter:-6 General Principles & Process of Isolation of Elements

Important Points :

1. The chemical substances in the earth's crust obtained by mining are called Minerals.
2. Minerals, which act as source for metal, are called Ore. From ore metal can be obtained economically .
3. The unwanted impurities present in ore are called Gangue.
4. The entire process of extraction of metal from its ore is called Metallurgy.
5. Removal of gangue from ore is called Concentration, Dressing or Benefaction of ore.
6. Concentration by Hydraulic washing is based on the difference in gravities of ore and gangue particles.
7. Concentration by Magnetic separation is based on differences in magnetic properties of ore components. If either of ore or gangue is capable of attracted by a magnet field, then such separation is carried out.
8. Concentration by Froth Flotation Process is based on the facts that sulphide ore is wetted by oil & gangue particles are wetted by water.
9. Concentration by Leaching is based on the facts that ore is soluble in some suitable reagent & gangue is insoluble in same reagent. e.g. Bauxite ore contains impurities of silica, iron oxide & TiO_2 .The powdered ore is treated with NaOH which dissolve Al & impurities remains insoluble in it.



10. Calcination involves heating of ore in absence of air below melting point of metal. In this process volatile impurities escapes leaving behind metal oxide.

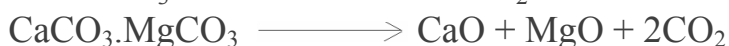

11. Roasting involves heating of ore in presence of air below melting point of metal in reverberatory furnace. In this process volatile impurities escapes leaving behind metal oxide and metal sulphide converts to metal oxide.



12. Reduction of metal oxide involves heating of metal in presence of suitable reagent Coke or CO_2 .

13. Reactions taking place at different zones of blast furnace in extraction of iron:-

(i) Zone of reduction:- Temperature range 250°C - 700°C

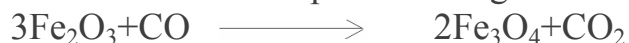

(ii) Zone of slag formation:- Temperature range 800°C - 1000°C

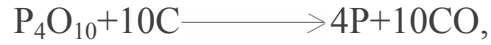
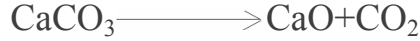

(iii) Zone of fusion: - Temperature range 1150°C-1350°C

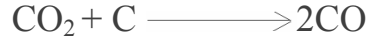

(iv) Zone of fusion: - Temperature range 1450°C-1950°C



14. FLOW SHEET FOR EXTRACTION OF IRON:-

Iron ore (Magnetite
Fe₃O₄) (Haematite Fe₂O₃)



Concentration is done by Gravity separation followed by magnetic separation



Calcination & Roasting i.e. Ore + Air + Heat → Moisture, CO₂, SO₂, As₂O₃ removed And FeO oxidized to Fe₂O₃



Smelting of charge i.e. mixture of ore, coke & CaCO₃ takes place in long BLAST FURNACE. Following reaction take place at different zones:-
(refer to point 13)



Pig iron is obtained, which is remelted and cooled then cast iron is obtained

15. Pig Iron: - It contains Fe 93-95%, Carbon 2.5-5%, and Impurities 3%.

16. Cast Iron: - It contains Fe 99.5-99.8%, Carbon 0.1-0.2% Impurities 0.3%.

17. Spongy iron: - Iron formed in the zone of reduction of blast furnace is called spongy iron. It contains impurities of C, Mn, Si, etc.

18. FLOW SHEET FOR EXTRACTION OF COPPER:-

Copper Pyrites CuFeS₂



Concentration is done by Froth floatation process
Powdered ore + water + pine oil + air → Sulphide ore in the froth



Roasting is presence of air. following reactions take place:-
S + O₂ → SO₂, 4As + 3O₂ → 2As₂O₃, 2CuFeS₂ + O₂
→ Cu₂S + 2FeS + SO₂



Smelting in small blast furnace of a mixture of Roasted ore, coke, and silica.
2FeS + 3O₂ → 2FeO + 2SO₂, FeO + SiO₂ → FeSiO₃ (slag)

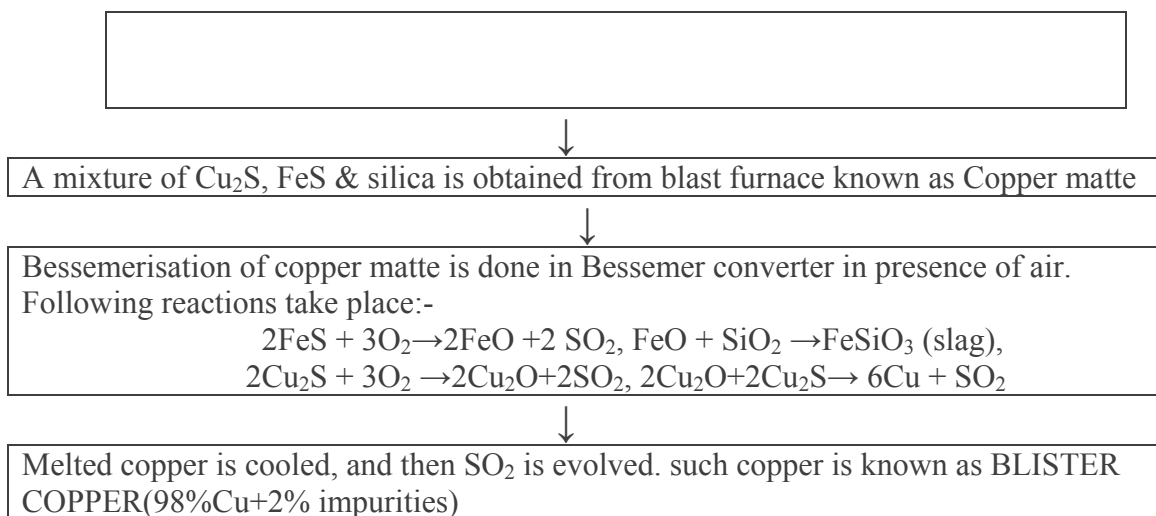

19. FLOW SHEET FOR EXTRACTION OF ALUMINIUM:-

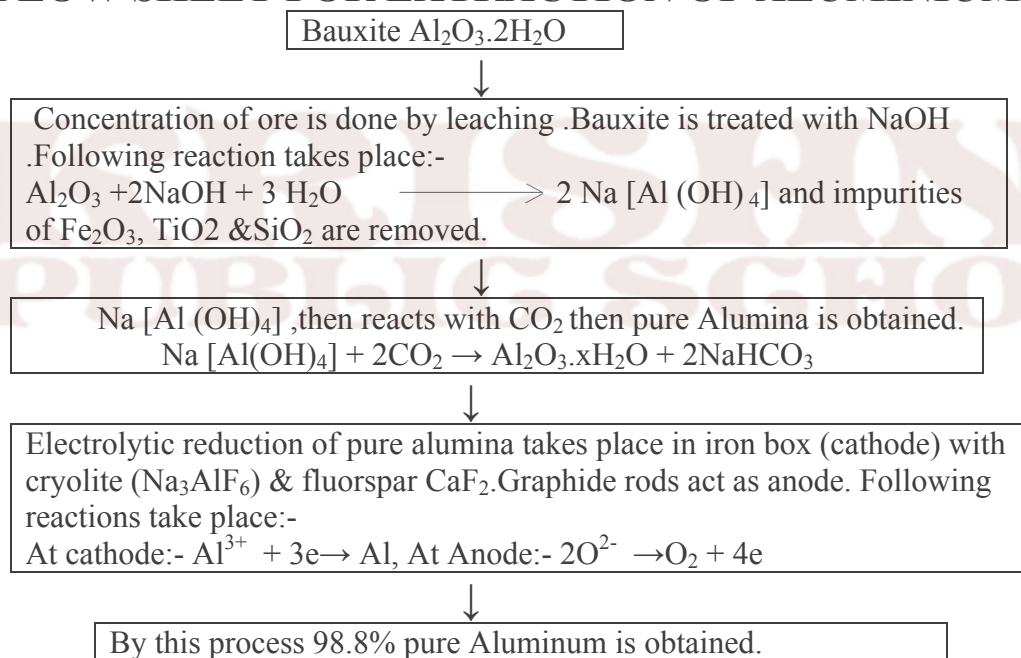

20. Vapour phase refining is used for extraction of Nickel (MOND PROCESS) and Zirconium & Titanium (VAN ARKEL PROCESS).

21. Zone refining is used for extraction of Si, Ge, Ga, etc.

22. Chromatography method is based on selective distribution of various constituents of a mixture between two phases, a stationary phase and a moving phase. The stationary phase can be either solid or liquid on solid support.

22. Column chromatography is based on adsorption phenomenon. This method is useful for those elements, which are available in small amounts and the impurities are not much different in chemical properties from the element to be purified.

VERY SHORT ANSWER TYPE QUESTION

(1 marks)

Q.1- What is slag?

A.1- It is easily fusible material, which is formed when gangue still present in roasted ore combines with the flux.

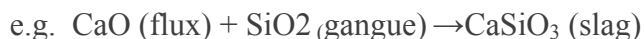

Q.2- Which is better reducing agent at 983K, carbon or CO?

A.2- CO, (above 983K CO being more stable & does not act as a good reducing agent but carbon does.)

Q.3- At which temperature carbon can be used as a reducing agent for FeO ?

A.3- Above 1123K, carbon can reduce FeO to Fe.

Q.4- What is the role of graphite rods in electrometallurgy of aluminium ?

A.4- Graphite rods act as anode, are attacked by oxygen to form CO_2 and so to be replaced time to time.

Q.5- What is the role of cryolite in electrometallurgy of aluminium?

A.5- alumina cannot be fused easily because of high melting point. Dissolving of alumina in cryolite furnishes Al^{3+} ions, which can be electrolyzed easily.

Q.6- What are depressants?

A.6- It is possible to separate two sulphide ore by adjusting proportion of oil to water in froth flotation process by using a substance known as depressant.

e.g. NaCN is used to separate ZnS and PbS.

Q.7- Copper can be extracted by hydrometallurgy but not Zn. Why?

A.7- The E^0 of Zn is lower than that of Cu thus Zn can displace Cu^{2+} ion from its solution. On other hand side to displace Zn from Zn^{2+} ion, we need a more reactive metal than it.

Q.8- Give name and formula of important ore of iron .

A.8- Haematite – Fe_2O_3 , Magnetite – Fe_3O_4 , Iron pyrites FeS_2 .

Q.9- Give name and formula of important ore of Copper .

A.9- Copper pyrites CuFeS_2 , Malachite $\text{CuCO}_3 \cdot \text{Cu (OH)}_2$, Cuprite Cu_2O .

Q.10- Give name and formula of important ore of Zinc .

A.10- Zinc blende - ZnS, Calamine- ZnCO_3 , Zincite – ZnO .

SHORT ANSWER TYPE QUESTION

(2 marks)

Q.1 Describe the method of refining of nickel.

A.1- In the Mond Process, Ni is heated in a stream of CO forming a volatile complex, which then decomposes at higher temperature to give Ni.



Q.2- What is Zone Refining? Explain with example.

A.2- Zone refining is a method of obtaining a metal in very pure state. It is based on the principle that impurities are more soluble in molten state of metal than solidified state.

In this method, a rod of impure metal is moved slowly over circular heater. The portion of the metal being heated melts & forms the molten zone. As this portion of the rod moves out of heater, it solidifies while the impurities pass into molten zone. The process is repeated to obtain ultrapure metal and end of rod containing impure metal cutoff.

Q.3 Write the principle of electro-refining.

A.3- In this method of purification impure metal is made Anode and pure metal is made the cathode. On passing electricity, pure metal is deposited at the cathode while the impurities dissolve in solution as anode mud. E.g. electro-refining of copper:-



Q.4- Write difference between calcinations and roasting .

A.4- Refer points no 10 & 11.

Q.5- Describe the method of refining of Zirconium and Titanium.

A.5- Van Arkel process is used for obtaining ultrapure metal. The impure metal is converted into volatile compound, which then decomposes electrically to get pure metal.

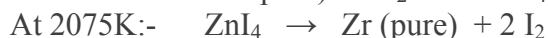

Q.6- Out of C & CO, which is better reducing agent for ZnO?

A.6- Since free energy of formation of CO from C is lower at temperature above 1120K while that of CO₂ from carbon is lower above 1323K than free energy of formation of ZnO. However, the free energy of formation of CO₂ from CO is always higher than that of ZnO. Hence, C is better reducing agent of ZnO.

Q.7- The value of $\Delta_f G^0$ for Cr₂O₃ is -540kJ/mole & that of Al₂O₃ is -827kJ/mole. Is the reduction of Cr₂O₃ possible with aluminium?

A.7- The desired conversion is



It is obtained by addition of following two reactions:-

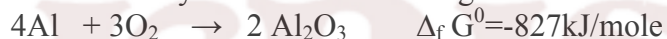

Therefore, ΔG^0 for desired reaction is $-827+540=-287$, as a result reduction is possible.

Q.8:- Why copper matte is put in silica lined converter?

A.8:- Copper matte consists of Cu₂S and FeS. When blast of air is passed through molten matte in silica-lined converter, FeS present in matte is oxidized to FeO, which combines with silica to form slag.



Q.9- What is meant by term chromatography?

A.9-Chromato means Colour and graphy means writing because the method was first used for separation of coloured substance. It is based on selective distribution of various constituents of a mixture between two phases, a stationary phase and a moving phase. The stationary phase can be either solid or liquid on solid support.

Q.10-Why is reduction of metal oxide easier if metal formed is in liquid state at temperature of reduction.

A.10- The entropy of a substance is higher in liquid state than solid state. In the reduction of metal oxide, the entropy change will be positive if metal formed is in liquid state. Thus, the value of ΔG^0 becomes negative and reduction occurs easily.

SHORT ANSWER TYPE QUESTION

(3 marks)

Q.1- Explain the following:-

(i) Zinc but not copper is used for recovery of Ag from the complex $[\text{Ag}(\text{CN})_2]^-$.

(ii) Partial roasting of sulphide ore is done in the metallurgy of copper.

(iii) Extraction of Cu from pyrites is difficult than that from its oxide ore through reduction.

A.1- (i) Zn is more powerful reducing agent in comparison to copper. Zn is also cheaper than Cu.

(ii) Partial roasting of sulphide ore forms some oxide. This oxide then reacts with remaining sulphide ore to give copper i.e. self-reduction occurs.

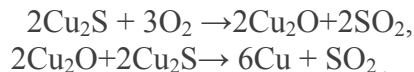

(iii) Though carbon is good reducing agent for oxide but it is poor reducing agent for sulphides. The reduction of metal sulphide does not have large negative value.

Q.2- Explain the method for obtaining pig iron from magnetite.

A.2- Extraction of iron from Magnetite takes place in following steps:-

(i) Concentration of ore: - It is done by Gravity separation followed by magnetic separation process.

(ii) Calcination: - It involve heating when the volatile matter escapes leaving behind metal oxide.

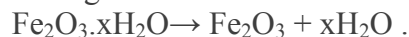

(iii) Roasting: - It involves heating of ore in presence of air, thus moisture, CO_2 , SO_2 , As_2O_3 removed And FeO oxidized to Fe_2O_3 .

(iv) Smelting of roasted ore: - A mixture of ore, coke & CaCO_3 is smelted in long BLAST FURNACE.

Following reaction takes place at different temperature zones:-

(i) Zone of reduction: - Temperature range 250°C - 700°C

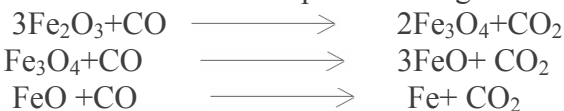

(ii) Zone of slag formation:- Temperature range 800°C - 1000°C

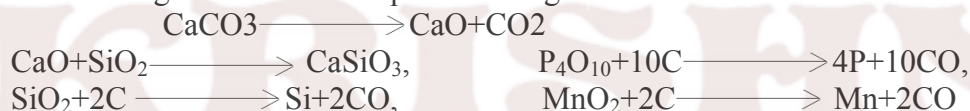

(iii) Zone of fusion:- Temperature range 1150°C - 1350°C



(iv) Zone of fusion:- Temperature range 1450°C - 1950°C



Thus, Pig iron is obtained from Blast Furnace.

Q.3- Describe the principles of extraction of copper from its ore .

A.3- Refer points no 18. For steps, involve in the extraction.

Q.4- Name the principal ore of aluminium and describe how Al is extracted from its ore.

A.4- Important ores -(i) Bauxite $\text{Al}_2\text{O}_3 \cdot x\text{H}_2\text{O}$ (ii) Corundum Al_2O_3 . Bauxite is commercially important ore Al.

Extraction from Bauxite ore involves the following two stages:-

(i) Purification of bauxite to get pure alumina (Al_2O_3)

(ii) Electrolysis of pure alumina in molten cryolite

Step:-1 Bauxite is treated with NaOH . Following reaction takes place:-

$\text{Al}_2\text{O}_3 + 2\text{NaOH} + 3\text{H}_2\text{O} \longrightarrow 2\text{Na}[\text{Al}(\text{OH})_4]$ and impurities of Fe_2O_3 , TiO_2 & SiO_2 are removed. $\text{Na}[\text{Al}(\text{OH})_4]$, then reacts with CO_2 then pure Alumina is obtained.



Step:-2 Electrolytic reduction of pure alumina takes place in iron box (cathode) with cryolite (Na_3AlF_6) & fluorspar CaF_2 . Graphide rods act as anode. Following reactions take place:-



By this process

98.8% pure Aluminum is obtained.

Q.5- Describe the principles of extraction of Zinc from zinc blende .

A.5- Important ores of Zn:-Zinc blende - ZnS, Calamine- ZnCO₃, and Zincite – ZnO. ZnS is commercially important ore of Zn. Various stages involved in the extraction of Zn from ZnS are as following:-

(i) Concentration of ore:-It is concentrated by Froth flotation process followed by gravity separation process.

(ii) Roasting:- The concentrated ore is roasted in presence of air. Following reactions take place:-

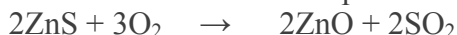

The mass obtained during roasting is porous and is called porous clinker.

(iii) Reduction of ZnO to Zn: - ZnO is made into bricketts with coke and clay and heated at 1633K. Zn formed distills off and is collected by rapid cooling of zinc vapours.

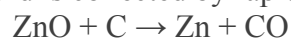

Unit-16 CHEMISTRY IN EVERYDAY LIFE

POINTS TO BE REMEMBERED

- 1. DRUGS –** Drugs are chemical of low molecular masses, which interact with macromolecular targets and produce a biological response.
- 2. CHEMOTHERAPY-** The use of chemicals for therapeutic effect is called chemotherapy.
- 3. CLASSIFICATION OF DRUGS –**
 - (a) ON THE BASIS OF PHARMACOLOGICAL EFFECT-**drugs for a particular type of problem as analgesics-----for pain relieving.
 - (b) ON THE BASIS OF DRUG ACTION-**Action of drug on a particular biochemical process.
 - (c) ON THE BASIS OF CHEMICAL ACTION-**Drugs having similar structure .eg-sulpha drugs.
 - (d) ON THE BASIS OF MOLECULAR TARGETS-** Drugs interacting with biomolecules as lipids, proteins.
- 4. ENZYMES AS DRUG TARGETS**
 - (i) CATALYTIC ACTION OF EN ZYMES-**
 - (a)** Enzymes have active sites which hold the substrate molecule .it can be attracted by reacting molecules.
 - (b)** Substrate is bonded to active sites through hydrogen bonds, ionic bonds, Vander Waal or dipole –dipole interactions.
 - (ii) DRUG- ENZYME INTERACTIONS-**
 - (a)**Drug complete with natural substrate for their attachments on the active sites of enzymes .They are called competitive inhibitors.
 - (b)**Some drugs binds to a different site of the enzyme called allosteric sites which changes the shape of active sites.
- 5. ANTAGONISTS-** The drugs that bind to the receptor site and inhibit its natural function.
- 6. AGONISTS-**Drugs mimic the natural messenger by switching on the receptor.

7. **ANTACIDS**-These are compounds which neutralize excess acid of stomach.eg-Aluminium hydroxide, Magnesium hydroxide.
8. **ANTI HISTAMINES**-The drugs which interfere with the natural action of histamines and prevent the allergic reaction. eg- ranitidine, tegarnet, avil.
9. **TRANQUOLIZERS**-The class of chemical compounds used for the treatment of stress, mild or even severe mental diseases. Eg-idardil, iproniagid, luminal, second equaquil .
10. **ANALGESICS**-They reduce pain without causing impairment of consciousness, mental confusion or some other disturbance of the nervous system.

Eg - aspirin, seridon , phenacetin.

11. **ANTIMICROBIALS**-They tend to prevent/destroy or inhibit the pathogenic action of microbes as bacteria ,virus ,fungi etc .They are classified as

(i)**ANTIBIOTICS**-Those are the chemicals substances which are produced by micro-organisms.

Eg- Pencillin , ofloxacin .

NARROW SPECTRUM ANTI-BIOTICS-These are effective mainly against gram positive or gram negative bacteria. Eg- Penicillin , streptomycin.

BROAD SPECTRUM ANTI-BIOTICS-They kill or inhibit a wide range of micro-organisms.

eg- chloramphenicol , tetracycline .

(ii)**ANTISEPTICS OR DISINFECTANT**-These are which either kill/inhibit the growth of micro-organisms

Antiseptics are applied to the living tissues such as wounds, cuts, ulcers etc. eg- furacine, chloroxylenol & terpinol (dettol) .Disinfectant are applied to inanimate objects such as floors , drainage , system.

Eg- 0.2% solution of phenol is an antiseptic while 1% solution is an disinfectant.

12. **ANTIFERTILITY DRUGS**- These is the chemical substances used to control the pregnancy. They are also called oral contraceptives or birth control pills.

Eg-Mifepristone, norethindrone.

13. **ARTIFICIAL SWEETNING AGENTS**-These are the chemical compounds which give sweetening effect to the food without adding calorie.

They are good for diabatic people eg- aspartame, saccharin, alitame , sucrolose.

14. **FOOD PRESERVATIVES**- They prevents spoilage of food to microbial growth.eg-salt, sugar, and sodium benzoate.

15. **CLEANSING AGENTS**-

(i) **SOAPS**- They is sodium or potassium salts of long chain fatty acids.They are obtained by the soapnification reaction, when fatty acids are heated with aqueous sodium hydroxide.

They do not work well in hard water.

(iii) **TOILETS SOAP**-That are prepared by using better grade of fatty acids and excess of alkali needs to be removed .colour & perfumes are added to make them attractive.

(iv) **MEDICATED SOAPS**- Substances of medicinal value are added.eg- Buthional , dettol.

16. **SYNTHETIC DETERGENTS**-They are cleaning agents having properties of soaps, but actually contain no soap .They can used in both soft and hard water .They are-

(i)**ANIONIC DETERGENTS**-They are sodium salts of sulphonated long chain alcohols or hydrocarbons.eg-sodium lauryl sulphonate . They are effective in acidic solution.



(laurylalcohol)

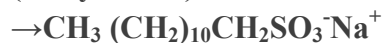

(Sodium lauryl sulphonate)

(ii)**CATIONIC DETERGENTS**- They are quarternary ammonium salts of amines with acetates , chlorides, or bromides.They are expensive used to limited extent.eg- cetyltrimethylammoniumbromide

(iii)**NON-IONIC DETERGENTS**- They does not contain any ions. Some liquid dishwashing detergents which are of non-ionic type .

17. **BIODEGREADABLE DETERGENTS**- The detergents which are linear and can be attacked by micro-organisms are biodegradable.

Eg -sodium 4-(1-dodecyl) benzene \ sulphonate.

18. **NON-BIODEGREADABLE DETERGENTS**- The detergents which are branched and cannot be decomposed by micro-organisms are called non-biodegradable.eg-sodium 4-(1,3,5,7 tetramethyloctyl)-benzene sulphonate .It creates water pollution.

VERY SHORT ANSWER TYPE QUESTION

(1 marks)

Q-1 Define the term chemotherapy?

Ans-1 Treatment of diseases using chemicals is called chemotherapy.

Q-2 why do we require artificial sweetening agents?

Ans-2 To reduce calorie intake.

Q-3 what are main constiuent of Dettol?

Ans-3 Chloroxylenol & Terpinol .

Q-4 what type drug phenaticinis?

Ans-4 It is antipyretics.

Q-5 Name the drug that are used to control allergy?

Ans-5 Antihistamines.

Q-6Why is the use of aspartame limited to cold food and drinks?

Ans-6 It is unstable at cooking temperature and decompose.

Q-7What is tranquilizers? Give an example?

Ans-7 They is the drug used in stress, mild severe mental disease.

Q-8 what type of drug chloramphenicol?

Ans-8 It is broad spectrum antibiotic.

Q-9Why is biothional is added to the toilet soap?

Ans-9It acts as antiseptics.

Q-10 what are food preservatives?

Ans-10 Phenol (0.2%), iodoform

SHORT ANSWER TYPE QUESTION

(3 marks)

Q-1 what are Biodegradable and non-biodegradable detergents? Give one example of each.

Ans-1 Detergents having straight hydrocarbon chain and are easily decomposed by micro-organisms are called Biodegradable detergents. The detergents having branched hydrocarbon chain and are not easily decomposed by micro-organisms are called Non-Biodegradable detergents.

Q-2 what are barbiturates? To which class of drugs do they belong? Give two examples.

Ans-2 Derivatives of barbituric acid are called barbiturates. They are tranquilizers. They also act as hypnotics. eg- luminal, seconal.

Q-3 what is the use of –

(i) Benadryl (ii) sodium benzoate (iii) Progesterone

Ans-3 (i) Antihistamines

(ii) Preservatives

(iii) Antifertility drug

Q-4 Identify the type of drug-

(i) Ofloxacin (ii) Aspirin (iii) Cimetidine

Ans-4 (i) Antibiotic (ii) Analgesics & Antipyretics

(iii) Antihistamines & antacid

Q-5 Describe the following with suitable example-

(i) Disinfectant (ii) Analgesics

(iii) Broad spectrum antibiotics

(i) Disinfectant- chemicals used to kill the micro-organisms can be applied on non-living articles.

(ii) Analgesics- They are the drugs which are used to relieve pain. eg – Aspirin, Ibuprofen.

(iii) Broad spectrum antibiotics- They kill the wide range of gram positive and gram negative bacteria.

Eg- Chloramphenicol, ofloxacin.

7. p-Block Elements

Points to remember:-

The general valence shell electronic configuration of p-block elements $ns^2 np^{1-6}$

GROUP 15 ELEMENTS:-

Group 15 elements ; N, P, As, Sb & Bi

General electronic configuration: $ns^2 np^3$

Physical Properties:-

- Dinitrogen is a diatomic gas while all others are solids.
- N & P are non-metals. As & Sb metalloids & Bi is a metals . this is due to decrease in ionization enthalpy & increase in atomic size .
- Electro negativity decreases down the group .

Chemical properties:-

- Common oxidation states : -3, +3 & +5.
- Due to inert effect, the stability of +5 state decreases down the group & stability of +3 state increases .
- In the case of Nitrogen all Oxidation states from +1 to +4 tend to disproportionate in acid solution , e.g.:- $3\text{HNO}_3 \rightarrow \text{H}_2\text{O} + 2\text{NO}$
Anamalous behavior of Nitrogen :- due to its small size, high electronegativity, high ionization enthalpy and absence of d-orbital.

N_2 has unique ability to $\pi\pi$ - $\pi\pi$ multiple bonds whereas the heavier of this group do not form $\pi\pi$ - $\pi\pi$ because there atomic orbitals are so large & diffuse that they cannot have effective overlapping.

Nitrogen exists as diatomic molecule with triple bond between the two atoms whereas other elements form single bonds in elemental state.

N cannot form $d\pi$ - $\pi\pi$ due to the non availability of d-orbitals whereas other elements can.

Trends In Properties:-

Stability - $\text{NH}_3 > \text{PH}_3 > \text{AsH}_3 > \text{SbH}_3 > \text{BiH}_3$

Bond Dissociation Enthalpy- $\text{NH}_3 > \text{PH}_3 > \text{AsH}_3 > \text{SbH}_3 > \text{BiH}_3$

Reducing character - $\text{NH}_3 > \text{PH}_3 > \text{AsH}_3 > \text{SbH}_3 > \text{BiH}_3$

Basic character- $\text{NH}_3 > \text{PH}_3 > \text{AsH}_3 > \text{SbH}_3 > \text{BiH}_3$

Acidic character- $\text{N}_2\text{O}_3 > \text{P}_2\text{O}_3 > \text{As}_2\text{O}_3 > \text{Sb}_2\text{O}_3 > \text{Bi}_2\text{O}_3$

Dinitrogen:-

Preparation

- Commercial preparation – By the liquification & fractional distillation of air.
- Laboratory preparation – By treating an aqueous solution NH_4Cl with sodium nitrate .
 $\text{NH}_4\text{Cl} + \text{NaNO}_2 \rightarrow \text{N}_2 + 2\text{H}_2\text{O} + \text{NaCl}$

- Thermal decomposition of ammonium dichromate also give N_2 .
 $(NH_4)_2Cr_2O_7 \rightarrow N_2 + 4H_2O + Cr_2O_3$
- Thermal decomposition of Barium or Sodium azide gives very pure N_2 .

PROPERTIES

At high temperature nitrogen combines with metals to form ionic nitride (Mg_3N_2) & with non-metals, covalent nitride.

AMMONIA PREPARATION

➤ In laboratory it is prepared by heating ammonium salt with NaOH or lime.

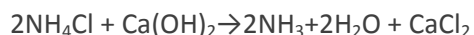

➤ In large scale it is manufactured by Haber 'process

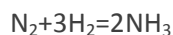

$$\Delta H^0 = -46.1 \text{ kJ/mol}$$

Acc.to Lechatelier's principle the favourable conditions for the manufacture of NH_3 are:-

Optimum temperature : 700 K

High pressure : 200 atm

Catalyst: Iron Oxides

Promoter : K_2O & Al_2O_3

PROPERTIES

Ammonia is a colorless gas with pungent odour.

Highly soluble in water.

In solids & liquid states it exists as an associated molecule due to hydrogen bonding which accounts for high melting & boiling points of NH_3

Trigonal Pyramidal shape NH_3 molecule.

Aqueous solution of ammonia is weakly basic due to the formation of OH^- ion .

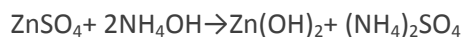

Ammonia can form coordinate bonds by donating its lone on nitrogen, ammonia forms complexes.

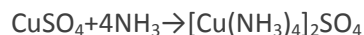

Name	Formula	Oxidation state	Chemical nature
Nitrous oxide or Laughing gas	N_2O	+1	Neutral

Nitric oxide	NO	+2	Neutral
Dinitrogen trioxide	N ₂ O ₃	+3	Acidic
Dinitrogen tetra oxide	N ₂ O ₄ or NO ₂	+4	Acidic
Dinitrogen pentaoxide	N ₂ O ₅	+5	Acidic

NITRIC ACID

PREPARATION: Ostwald's process – it is based upon catalytic oxidation of ammonia by atmospheric oxidation. The main steps are

- 1) $4\text{NH}_3 + 5\text{O}_2 \xrightarrow[500\text{K}, 9\text{BAR}]{\text{Pt}} 4\text{NO} + 6\text{H}_2\text{O}$
- 2) $2\text{NO} + \text{O}_2 \rightarrow 2\text{HNO}_3 + \text{NO}$

PROPERTIES:-

- (i) conc. HNO₃ is a strong oxidizing agent & attacks most metals gold & Pt.
- (ii) Cr & Al do not dissolve HNO₃ because of the formation of a positive film of oxide on the surface.
- (iii) it oxidises non metals like I₂ to HNO₃, C to CO₂, S to H₂SO₄
- (iv) brown ring test is used to detect NO⁻.

PHOSPHOROUS:-

ALLOTROPIC FORMS: White, red α-black & β-black.

White phosphorous is more reactive than red phosphorous because white P exists as discrete P₄ molecules. In red P several P₄ molecules are linked to form a polymeric chain.

PHOSPHINE

Preparation: It is prepared in laboratory by heating white P with concentrated NaOH solution in an

Inert atmosphere of CO₂ [$\text{P}_4 + 3\text{NaOH} + 3\text{H}_2\text{O} \rightarrow \text{PH}_3 + 3\text{NaH}_2\text{PO}_2$]

Phosphorous halides

Phosphorous forms two types of halides PX₃ & PX₅ (X=F, I, Br)

Trihalides have pyramidal shape and pentahalides have trigonal bipyramidal structure.

OXOACIDS OF PHOSPHOROUS

- The acids in +3 oxidation state disproportionate to higher & lower oxidation.



- Acids which contains P-H bond have strong reducing properties.EX:- H_3PO_2
Are ionisable and cause the basicity.
- Hydrogen atom which are attached with oxygen in P-OH form are ionisable

GROUP-16 ELEMENTS (CHALCOGENS)

Group 16 Elements:O,S,SE,TE,PO

General electronic configuration: ns^2np^4

Element	Occurrence
Oxygen	Comprises 20.946% by volume of the atmosphere.
Sulphur	As sulphates such as gypsum $\text{CaSO}_4 \cdot 2\text{H}_2\text{O}$, Epsom salt $\text{MgSO}_4 \cdot 7\text{H}_2\text{O}$ and sulphides Such as galena PbS, zinc blende ZnS, copper pyrites CuFeS_2 As metal selenides and tellurides in sulphide ores.
Se&Te	as a decay product of thorium and uranium minerals.

ATOMIC & PHYSICAL PROPERTIES

- Ionisation enthalpy decreases from oxygen to polonium.
- Oxygen atom has less negative electron gain enthalpy than S because of the compact nature of the oxygen atom. However from the S onwards the value again becomes less negative upto polonium.
- Electronegativity gradually decreases from oxygen to polonium, metallic character increases from oxygen to polonium.
- Oxygen & S are non-metals, selenium and tellurium are metalloids. Po is a radioactive metal.
- Oxygen is a diatomic gas while S, Se & Te are octa atomic S_8 , Se_8 & Te_8 molecules which has puckered 'ring' structure.

CHEMICAL PROPERTIES

- Common oxidation state:- -2,+2,+4 &+6.
- Due to inert effect,the stability of +6 decreases down the group and stability of +4 increases.

Oxygen exhibits +1 state in O_2F_2 ,+2 in OF_2 .

Anamolous behavior of oxygen-due to its small size,high electronegativity and absence of d-orbitals.

TREND IN PROPERTIES

Acidic character- $H_2O < H_2S < H_2Se < H_2Te$

Thermal stability- $H_2O > H_2S > H_2Se > H_2Te$

Reducing character- $H_2S < H_2Se < H_2Te$

Boiling point- $H_2S < H_2Se < H_2Te < H_2O$

Reducing property of dioxides- $SO_2 > SeO_2 > TeO_2$

Stability of halides- $F > Cl > Br > I$

HALIDES

DI HALIDES: sp^3 hybridisation but angular structure.

TETRA HALIDES: sp^3 hybridisation-see-saw geometry

HEXA HALIDES: sp^3d^2 ,octahedral SF_6

DIOXYGEN

Prepared by heating oxygen containing salts like chlorates,nitrares



SO2 molecule is angular.

OXIDES

A binary compound of oxygen with another element is called oxide. Oxides can be classified on the basis of nature

- **Acidic Oxides:-** Non metallic oxides. Aqueous solutions are acids. Neutralize bases to form salts.Ex: $\text{SO}_2, \text{CO}_2, \text{N}_2\text{O}_5$ etc.
- **Basic Oxides:**metallic oxides.Aqueous solutions are alkalis. Neutralize acids to form salts.Ex: $\text{Na}_2\text{O}, \text{K}_2\text{O}, \text{etc.}$
- **Amphoteric oxides:-**some metallic oxides exhibit a dual behavior. Neutralize both acids & bases to form salts.
Ex:- $\text{Al}_2\text{O}_3, \text{SbO}_2, \text{SnO}, \text{etc.}$

OZONE

PREPARATION

Prepared by subjecting cold, dry oxygen to silent electric discharge.

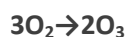

PROPERTIES

Due to the ease with which it liberates atoms of nascent oxygen, it acts as a powerful oxidizing agent. For eg:- it oxidises lead sulphide to lead sulphate and iodide ions to iodine.



SULPHUR DIOXIDE

PREPARATION

Burning of S in air

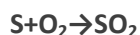

Roasting of sulphide minerals

(Iron pyrites)

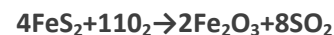

PROPERTIES

- Highly soluble in water to form solution of sulphurous acid
 $\text{SO}_2 + \text{H}_2\text{O} \rightarrow \text{H}_2\text{SO}_3$
- SO_2 reacts with Cl_2 to form sulphuryl chloride
 $\text{SO}_2 + \text{Cl}_2 \rightarrow \text{SO}_2\text{Cl}_2$

- It reacts with oxygen to form SO₃ in presence of V₂O₅ catalyst
 $2\text{SO}_2 + \text{O}_2 \rightarrow 2\text{SO}_3$
- Moist SO₂ behaves as a reducing agent. It converts Fe(III) ions to Fe(II) ions & decolourises acidified potassium permanganate (VII) solution (It is the test for the gas).

SULPHURIC ACID

PREPARATION

It is manufactured by contact process which involves 3 steps

1. Burning of S or Sulphide ores in air to generate SO₂.
2. Conversion of SO₂ to SO₃ in presence of V₂O₅ catalyst
3. Absorption of SO₃ in H₂SO₄ to give oleum.

PROPERTIES

1. In aqueous solution it ionizes in 2 steps



2. It is a strong dehydrating agent Eg:-charring action of sugar

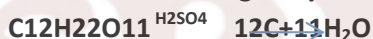

3. It is a moderately strong oxidizing agent.

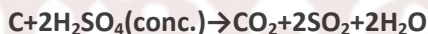
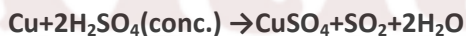

GROUP 17 ELEMENTS (HALOGENS)

Group 17 elements: F, Cl, Br, I, At

General electronic configuration: $ns^2 np^5$

Element	Occurrence
Fluorine	As insoluble fluorides (fluorspar CaF ₂ , Cryolite and fluoroapatite)
Cl, Br, I	Sea water contains chlorides, bromides and iodides of Sodium, potassium magnesium and calcium, but is mainly sodium chloride solution (2.5% by mass). Certain forms of marine life (various seaweeds)

--	--

ATOMIC & PHYSICAL PROPERTIES

- i. Atomic & ionic radii increase from fluorine to iodine.
- ii. Ionization enthalpy gradually decreases from fluorine to iodine due to increase in atomic size.
- iii. Electron gain enthalpy of fluorine is less than that of chlorine. It is due to small size of fluorine & repulsion between newly added electron & electrons already present in its small 2p orbital.
- iv. Electronegativity decreases from fluorine to iodine. Fluorine is the most electronegative element in the periodic table.
- v. The color of halogens is due to absorption of radiations in visible region which results in the excitation of outer electrons to higher energy level.
- vi. Bond dissociation enthalpy of fluorine is smaller than that of chlorine is due to electron-electron repulsion among the lone pair in fluorine molecules where they are much closer to each other than in case of chlorine. The trend: Cl-Cl > Br-Br > F-F > I-I.

CHEMICAL PROPERTIES

OXIDATION STATES:-1. However, chlorine, bromine & iodine exhibit +1, +3, +5, +7 oxidation states also.

Fluorine forms two oxides OF₂ and O₂F₂. These are essentially oxygen fluorides because of the higher electronegativity of fluorine than oxygen.

Anomalous behavior of fluorine- due to its small size, highest electronegativity, low F-F bond dissociation enthalpy and absence of d-orbitals.

TRENDS IN PROPERTIES

Oxidizing property – F₂ > Cl₂ > Br₂ > I₂

Acidic strength- HF < HCl < HBr < HI

Stability & bond dissociation enthalpy- HF > HCl > HBr > HI

Stability of oxides of halogens- I > Cl > Br

Ionic character of halides – MF > MCl > MBr > MI

CHLORINE

PREPARATION

1. $\text{MnO}_2 + 4\text{HCl} \rightarrow \text{MnCl}_2 + \text{Cl}_2 + 2\text{H}_2\text{O}$
2. $4\text{NaCl} + \text{MnO}_2 + 4\text{H}_2\text{SO}_4 \rightarrow \text{MnCl}_2 + 4\text{NaHSO}_4 + 2\text{H}_2\text{O} + \text{Cl}_2$
3. $2\text{KMnO}_4 + 16\text{HCl} \rightarrow 2\text{KCl} + 2\text{MnCl}_2 + 8\text{H}_2\text{O} + 5\text{Cl}_2$

4. DEACON'S PROCESS

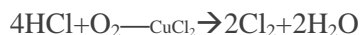

5. By electrolysis of brine solution. Cl₂ is obtained at anode.

PROPERTIES

- i. With cold and dilute Cl_2 produces a mixture of chloride and hypochlorite but with hot and concentrated alkalis it gives chloride and chlorate.



- ii. With dry slaked lime it gives bleaching powder.



- iii. It is a powerful bleaching agent; bleaching action is due to oxidation

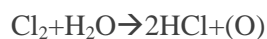

Colored substance + (O) \rightarrow colorless substance

- iv. Action of concentrated H_2SO_4 on NaCl give HCl gas.

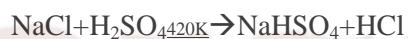

3:1 ratio of conc. HCl & HNO_3 is known as aquaregia & it is used for dissolving noble metals like Au and Pt .

OXOACIDS OF HALOGENS (SEE TABLE 7.10 & FIG.7.8)

Interhalogen compounds are prepared by direct combination of halogens.

Ex: ClF , ClF_3 , BrF_5 , IF_7

They are more reactive than halogens because $\text{X-X}'$ is weaker than X-X bonds in halogens (except F-F).

TYPE	STRUCTURE
XX'_3	Bent T-shaped
XX'_5	Square pyramidal
XX'_7	Pentagonal bipyramidal

GROUP 18 ELEMENTS

GROUP 18 ELEMENTS: He , Ne , Ar , Kr , Xe & Rn

General electronic configuration: ns^2np^6

Atomic radii- large as compared to other elements in the period since it corresponds to Vander Waal radii.

Inert – due to complete octet of outermost shell, very high ionization enthalpy & electron gain enthalpies are almost zero.

The first noble compound prepared by Neil Bartlett was $XePtF_6$ & Xenon.

$O_2^+PtF_6^-$ led to the discovery of $XePtF_6$ since first ionization enthalpy of molecular oxygen ($1175kJmol^{-1}$) was almost identical with that of xenon ($1170kJmol^{-1}$).

PROPERTIES

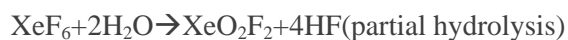
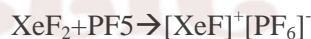
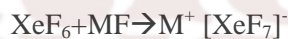
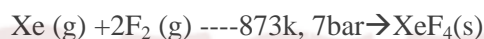

SOLVED QUESTIONS

1 MARK QUESTIONS

1. Ammonia has higher boiling point than phosphine. Why?
-AMMONIA FORMS INTERMOLECULAR H-BOND.
2. Why BiH_3 the strongest reducing agent amongst all the hydrides of group 15 elements ?
3. Why does PCl_3 fume in moisture ?

In the presence of (H_2O) , PCl_3 undergoes hydrolysis giving fumes of HCl .



4. What Happens when H_3PO_3 is Heated ?

It disproportionate to give orthophosphoric acid and Phosphine .



5. Why H_2S is acidic and H_2O is neutral ?

The S---H bond is weaker than O---H bond because the size of S atom is bigger than that of O atom. Hence H_2S can dissociate to give H^+ ions in aqueous solution.

6. Name two poisonous gases which can be prepared from chlorine gas ?

Phosgene (COCl_2), tear gas (CCl_3NO_2)

7. Name the halogen which does not exhibit positive oxidation state.

Fluorine being the most electronegative element does not show positive oxidation state.

8. Iodine forms I_3^- but F_2 does not form F_3^- ions. Why?

Due to the presence of vacant d-orbitals, I_2 accepts electrons from I-ions to form I_3^- ions, but because of d-orbitals F_2 does not accept electrons from F-ions to form F_3^- ions.

9. Draw the structure of peroxosulphuric acid.

10. Phosphorous forms PCl_5 but nitrogen cannot form NCl_5 . Why?

Due to the availability of vacant d-orbital in P.

2 MARK QUESTION (SHORT ANSWER TYPE QUESTION)

1. Why is HF acid stored in wax coated glass bottles?

This is because HF does not attack wax but reacts with glass. It dissolves SiO_2 present in glass forming hydrofluorosilicic acid.



2. What is laughing gas? Why is it so called? How is it prepared?

Nitrous oxide (N_2O) is called laughing gas, because when inhaled it produced hysterical laughter. It is prepared by gently heating ammonium nitrate.



3. Give reasons for the following:

(i) Conc. HNO_3 turns yellow on exposure to sunlight.

(ii) PCl_5 behaves as an ionic species in solid state.

(i) Conc HNO_3 decompose to NO_2 which is brown in colour & NO_2 dissolves in HNO_3 to it yellow.

(ii) It exists as $[\text{PCl}_4]^+[\text{PCl}_6]^-$ in solid state.

4. What happens when white P is heated with conc. NaOH solution in an atmosphere of CO_2 ? Give equation.

Phosphorus gas will be formed.

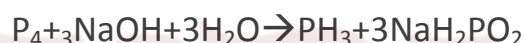

5. How is ozone estimated quantitatively?

When ozone reacts with an excess of potassium iodide solution

Buffered with a borate buffer (pH 9.2), Iodide is liberated which can be titrated against a standard solution of sodium thiosulphate. This is a quantitative method for estimating O_3 gas.

6. Are all the five bonds in PCl_5 molecule equivalent? Justify your answer.

PCl_5 has a trigonal bipyramidal structure and the three equatorial P-Cl bonds are equivalent, while the two axial bonds are different and longer than equatorial bonds.

7. NO_2 is coloured and readily dimerises. Why?

NO_2 contains odd number of valence electrons. It behaves as a typical odd molecules. On dimerization; it is converted to stable N_2O_4 molecule with even number of electrons.

8. Write the balanced chemical equation for the reaction of Cl₂ with hot and concentrated NaOH. Is this reaction a disproportionation reaction? Justify:



Yes, chlorine from zero oxidation state is changed to -1 and +5 oxidation states.

9. Account for the following.

(i) SF₆ is less reactive than.

(ii) Of the noble gases only xenon chemical compounds.

(i) In SF₆ there is less repulsion between F atoms than in SF₄.

(ii) Xe has low ionisation enthalpy & high polarising power due to larger atomic size.

10. With what neutral molecule is ClO⁻ isoelectronic? Is that molecule a Lewis base?

ClF. Yes, it is Lewis base due to presence of lone pair of electron.

3 MARK QUESTIONS

1(i) why is He used in diving apparatus?

(ii) Noble gases have very low boiling points. Why?

(iii) Why is ICl more reactive than I₂?

(i) It is not soluble in blood even under high pressure.

(ii) Being monoatomic they have weak dispersion forces.

(ii) I-Cl bond is weaker than I-I bond

2. Complete the following equations.

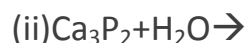
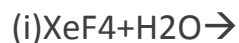

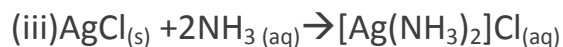
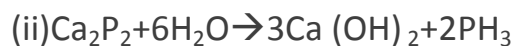
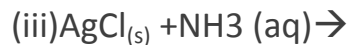

3. (i) How is XeOF_4 prepared? Draw its structure.

(ii) When HCl reacts with finely powdered iron, it forms ferrous chloride and not ferric chloride. Why?

(i) Partial hydrolysis of XeOF_4



Structure-square pyramidal. See Fig 7.9

(ii) Its reaction with iron produces H_2



Liberation of hydrogen prevents the formation of ferric chloride.

5 MARK QUESTION

1. Account for the following.

(i) Noble gas form compounds with F_2 & O_2 only.

(ii) Sulphur shows paramagnetic behavior.

(iii) HF is much less volatile than HCl.

(iv) White phosphorous is kept under water.

(v) Ammonia is a stronger base than phosphine.

(i) F_2 & O_2 are best oxidizing agents.

(ii) In vapour state sulphur partly exists as S_2 molecule which has two unpaired electrons in the antibonding π^* orbitals like O_2 and, hence, exhibit paramagnetism.

(iii) HF is associated with intermolecular H bonding.

(iv) Ignition temperature of white phosphorous is very low (303 K). Therefore on exposure to air, it spontaneously catches fire forming P_4O_{10} . Therefore to protect it from air, it is kept under water.

(v) Due to the smaller size of N, lone pair of electrons is readily available.

2. When Conc. H_2SO_4 was added to an unknown salt present in a test tube, a brown gas (A) was evolved. This gas intensified when copper turnings were added in to test tube. On cooling gas (A) changed in to a colourless gas (B).

(a) Identify the gases 'A' and 'B'

(b) Write the equations for the reactions involved

The gas 'A' is NO_2 whereas 'B' is N_2O_4 .

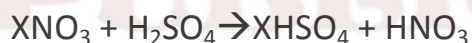

Salt (conc.)



Blue Brown (A)



Colourless(B)

3. Arrange the following in the increasing order of the property mentioned.

(i) $HOCl$, $HClO_2$, $HClO_3$, $HClO_4$ (Acidic strength)

(ii) As_2O_3 , ClO_2 , GeO_3 , Ga_2O_3 (Acidity)

(iii) NH_3 , PH_3 , AsH_3 , SbH_3 (HEH bond angle)

(iv) HF, HCl, HBr, HI (Acidic strength)

(v) MF, MCl, MBr, MI (ionic character)

(i) Acidic strength: $\text{HOCl} < \text{HClO}_2 < \text{HClO}_3 < \text{HClO}_4$

(ii) Acidity: $\text{Ga}_2\text{O}_3 < \text{GeO}_2 < \text{AsO}_3 < \text{ClO}_2$

(iii) Bond angle: $\text{SbH}_3 < \text{AsH}_3 < \text{PH}_3 < \text{NH}_3$

(iv) Acidic strength: $\text{HF} < \text{HCl} < \text{HBr} < \text{HI}$

(v) Ionic character: $\text{MI} < \text{MBr} < \text{MCl} < \text{MF}$

ASSIGNMENTS

Very short answer type questions:

- 1) PH_3 has lower boiling point than NH_3 . Explain.
- 2) Why are halogens coloured.
- 3) What are chalcogens?
- 4) Which noble gas is Radioactive?
- 5) Explain why fluorine always exhibit an oxidation state of - 1 only.
- 6) Which compound led to the discovery of compounds of noble gas?
- 7) Name the most electronegative element.
- 8) Why is OF_6 compound not known?
- 9) Why is N_2 not particularly reactive?
- 10) Ammonia acts as aligned. Explain.

Short answer type questions:

- 1) Write Phosphorous is more reactive than red phosphorous. Explain.

2) Why do noble gases have comparatively large atomic sizes?

3) Arrange in decreasing order of Ionic character

M – F, M – Cl, M – Br, M – I

4) Phosphinic acid behaves as a monoprotic acid

5) Arrange the following in the order of property indicated:

a) As_2O_3 , ClO_2 , GeO_2 , Ga_2O_3 ___ Increasing acidity

b) H_2O , H_2S , H_2Se , H_2Te ___ Increasing acid strength.

6) Arrange in decreasing order of bond energy:

F_2 , Cl_2 , Br_2 , I_2

7) Complete the following:

i) $\text{HNO}_3 + \text{P}_4\text{O}_{10} \rightarrow$

ii) $\text{IO}_3^- + \text{I}^- + \text{H}^+ \rightarrow$

8) Give the chemical reactions in support of following observations:

a) The +5 oxidation state of Bi is less stable than +3 oxidation state.

b) Sulphur exhibits greater tendency for catenation than selenium.

9) How would you account for following?

i) Enthalpy of dissociation of F_2 is much less than that of Cl_2 .

ii) Sulphur in vapour state exhibits paramagnetism.

10) Draw structures of following:

a) Pre-oxomonosalphuric acid H_2SO_5

b) XeF_4

Level – III

1. Complete and balance:

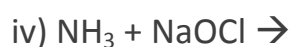
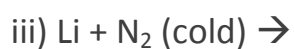
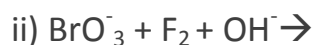
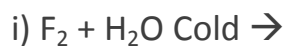

2) Despite lower electron affinity of F_2 , is stronger oxidising agent than Cl_2 . Explain.

3) Give reasons:

a) Nitric oxide becomes brown when released in air.

b) PCl_5 is ionic in nature in the solid state.

4) Which of the two is more covalent $SbCl_3$ or $SbCl_5$?

5) Addition of Cl_2 to KI solution gives a brown colour but excess of it turns it colourless. Explain.

Identify hybridization state of central atom and use concept of VSEPR theory . also its shape (geometry) and draw the structure.

PCl_3	sp^3	bp=3	lp=1	
PCl_5	sp^3d	bp=5	lp=0	
BrF_3	sp^3d	bp=3	lp=2	
XeF_2	sp^3d	bp=2	lp=3	
XeF_4	sp^3d^2	bp=4	lp=2	
$XeOF_4$	sp^3d^2	bp=5	lp=1	
XeO_3	sp^3	bp=3	lp=1	
XeF_6	sp^3d^3	bp=6	lp=1	
SF_4	sp^3d	bp=4	lp=1	

Formula	Resonance Structures	Bond Parameters
N_2O	$\ddot{N}=N=\ddot{O} \leftrightarrow :N\equiv N-\ddot{O}:$	$N - N - O$ 113 pm 119 pm Linear
NO	$:\dot{N} = \ddot{O}:\leftrightarrow :\ddot{N} = \dot{O}:$	$N - O$ 115 pm
N_2O_3		 Planar
NO_2		 Angular
N_2O_4		 Planar
N_2O_5		 Planar

KRISHNA PUBLIC SCHOOL

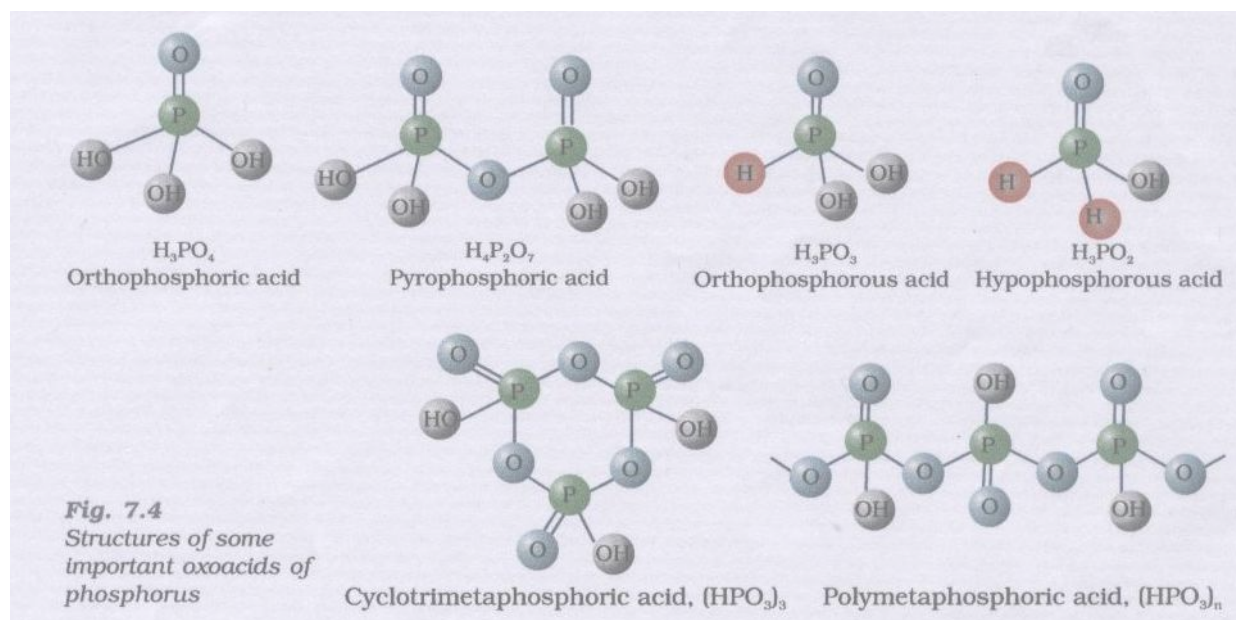
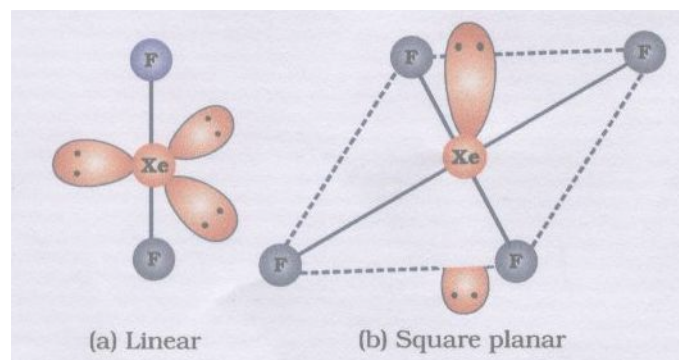
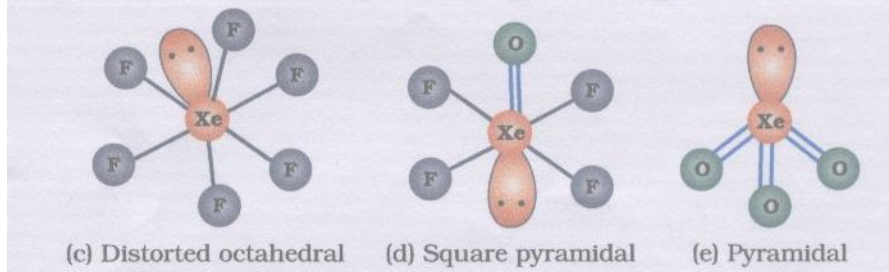
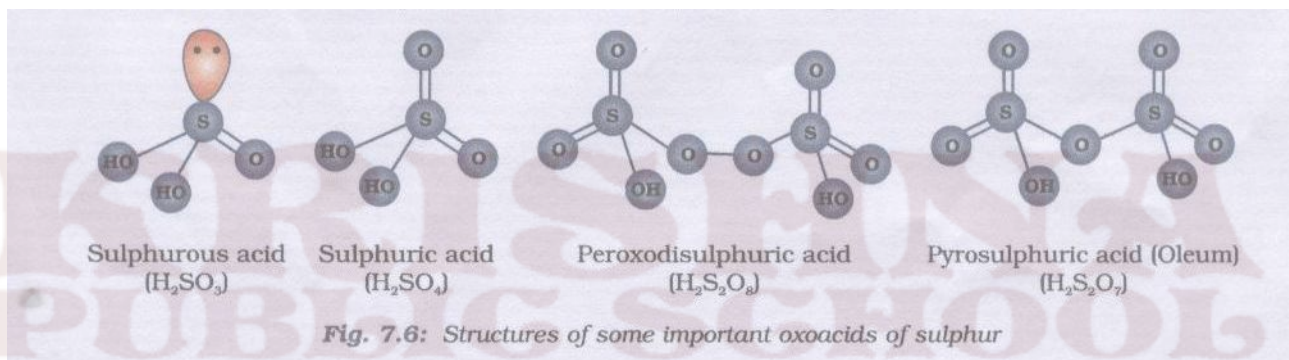
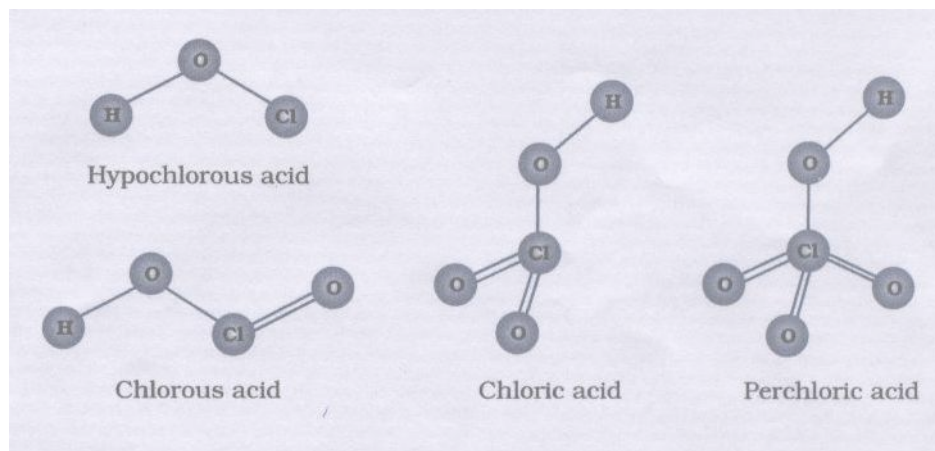
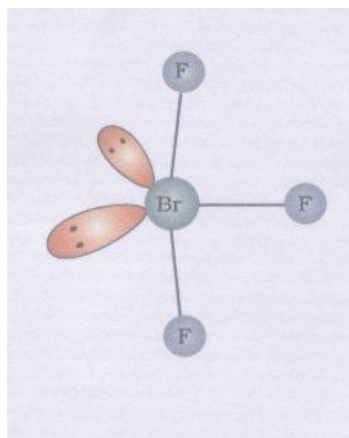
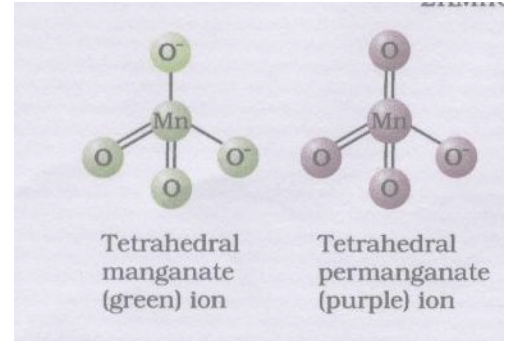
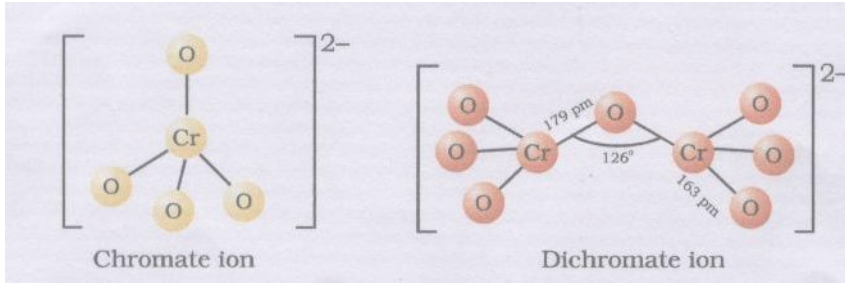

Fig. 7.4 Structures of some important oxoacids of phosphorus





KRISHNA
PUBLIC SCHOOL

Chapter:-8 The d-and f-Block Elements

POINTS TO BE REMEMBERED: ---

1. The elements of periodic table belonging to group 3 to 12 are known as d-Block elements.
2. The general electronic configuration of these elements is $(n-1)d^{1-10} ns^{1-2}$
3. d- Block elements are collectively known as Transition Elements because properties of these elements vary in between s-Block and p-Block elements.
4. A transition element should have partially filled $(n-1) d$ orbital.
5. Group 12 elements i.e. Zn, Cd, Hg have completely filled $(n-1) d$ -orbital in atomic & ionic state & thus these elements are considered as Typical Transition Elements.
6. All these elements are metals. They are less electropositive than s-block elements & more electropositive than p-block elements.
7. The atomic radii decreases from group 3 to 6 (i.e. Sc to Cr) because of increase in effective nuclear charge gradually.
8. The atomic radii of group 7,8 9 &10 elements (i.e. Fe,Co,Ni) is almost same because pairing of electrons take place in $(n-1)d$ orbital causing repulsion i.e. shielding of $(n-1)d$ orbital.
9. Group 11 &12 elements i.e. Cu & Zn have bigger size due to strong shielding of completely filled $(n-1)d$ orbital.
10. The transition elements show variable oxidation state due to small energy difference between $(n-1)d$ & ns orbital as a result both $(n-1)d$ & ns electrons take part in bond formation.
11. The highest oxidation state of an element is equal to number of unpaired electrons present in $(n-1)d$ & ns orbital.
12. Transition elements have high enthalpy of atomization/ sublimation Because of large number of unpaired electrons in their atoms, they have stronger interatomic interaction and hence strong metallic bonding is present between atoms.
13. Most of transition elements are paramagnetic due to presence of unpaired electrons in $(n-1) d$ orbital.
14. Most of transition elements are used as catalyst. It is due to (i) partially filled $(n-1) d$ orbital (ii) Variable oxidation state (iii) Ability to change oxidation state frequently.
15. Most of transition elements form coloured compounds due to presence of unpaired electrons in $(n-1) d$ orbital & thus they can undergo d-d transition.
16. Most of transition elements form complex compounds due to (i) small size (ii) high charge (iii) presence of vacant d-orbital of suitable energy.
17. Transition elements have lower value of Reduction Potential due to high ionization potential, high heat of sublimation & low enthalpy of hydration.
18. Transition elements form interstitial compounds because size of interstitial voids is similar to size of non- metals C, N, O, H.
19. Transition elements form alloys due to similar ionic radii.
20. The oxides of transition metals in lower oxidation state are BASIC, intermediate oxidation state are AMPHOTERIC, highest oxidation state are ACIDIC.

LANTHANOIDS: ---

1. The 14 elements after Lanthanum having atomic number 58 to 71 are collectively known as Lanthanoids.
2. The general electronic configuration of these elements is $[Xe] 4f^{1-14}, 5d^{0-1}, 6s^2$.
3. Most common oxidation state of these elements is +3, but Ce shows +4, Eu +2, because they acquire stable configuration.
4. The size of Lanthanoids and its trivalent ion decreases from La to Lu due to poor shielding of 4f electrons. It is known as lanthanoids contraction.

ACTINOIDS:--

1. The 14 elements after Actinium having atomic number 90 to 113 are collectively known as Actinoids.

- The general electronic configuration of these elements is $[\text{Rn}] 5f^{1-14}, 6d^{0-1}, 7s^2$.
- The size of actinoids and its trivalent ion decreases from Ac to Lw due to poor shielding of 5f electrons. It is known as actinoids contraction.
- The elements after U (92) are man made known as transuranic elements.

POTASSIUM DICHROMATE:--

Preparation: - It takes place in three steps-

- Conversion of chromite ore to sodium chromate.
- Conversion of sodium chromate to sodium dichromate.
- Conversion of sodium dichromate to potassium dichromate

Following reaction take place:--

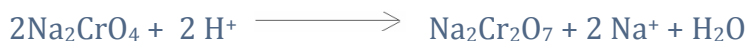
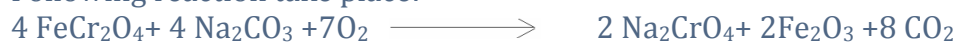

The chromates and dichromates are interconvertible in aqueous solution depending upon Ph of the solution.

A) In Acedic medium(PH<7)



B) In basic medium (PH >7)

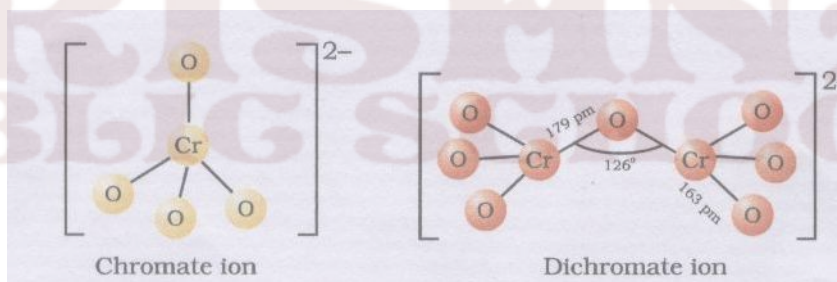

POTASSIUM PERMANGNATE:--

Preparation: --

It takes place in two steps:-

- Conversion of pyrolusite ore into potassium magnate
- Conversion of potassium magnate to potassium permanganate

Following reactions take place:-



QUESTION ANSWERS

(TWO MARK QUESTIONS)

Q.1-Explain briefly how +2 oxidation state becomes more and more stable in the first half of the first row transition elements with increasing atomic number.

A.1-In M^{2+} ions, 3d-orbitals get occupied gradually as the atomic number increases. Since, the number of empty d-orbitals decreases, the stability of cations increases from Sc^{2+} to Mn^{2+} . Mn^{2+} is most stable as all d-orbitals are singly occupied.

Q.2- Explain why transition elements have many irregularities in their electronic configurations?

A.2-In the transition elements, there is a little difference in the energy of (n-1) d-orbitals and ns-orbitals. Thus, incoming electron can occupy either of shell. Hence, transition elements exhibit many irregularities in their electronic configurations.

Q.3-What are different oxidation states exhibited by Lanthanides?

A.3-The common stable oxidation state of lanthanides is +3. However some members also show oxidation states of +2 & +4.

Q.4-How is the variability in oxidation states of transition metals different from that of the non-transition metals? Illustrate with examples.

A.4-The transition elements use its (n-1)d, ns and np orbital and the successive oxidation states differ by unity. For example, Mn shows all the oxidation states from +2 to +7. On other hand non transition elements use its ns, np and nd orbitals and the successive oxidation states differ by two units e.g. Sn²⁺, Sn⁴⁺ etc.

Q.5- Why do transition elements show variable oxidation states?

A.5- The transition elements show variable oxidation state due to small energy difference between (n-1) d & ns orbital as a result both (n-1)d & ns electrons take part in bond formation.

Q.6-Why are Mn²⁺ compounds more stable than Fe²⁺ compounds towards oxidation to +3 state?

A.6-The electronic configuration of Mn²⁺ is [Ar] 3d⁵, i.e. all five d-orbitals are singly occupied. Thus this is stable electronic configuration and further loss of electron requires high energy. On other hand side the electronic configuration of Fe²⁺ is [Ar] 3d⁶, i.e. Loss of one electron requires low energy.

Q.7-To what extent do the electronic configuration decide the stability of oxidation state in the first series of the transition elements? Illustrate your answer with an example.

A.7-In a transition series, the oxidation state which lead to exactly half filled or completely filled orbitals are more stable. e.g. the electronic configuration of Fe is [Ar] 3d⁶, 4s². It shows various oxidation state but Fe(III) is more stable than Fe(II).

Q.8-What is meant by disproportionation? Give two examples.

A.8-Those reactions in which same substance undergoes oxidation as well as reduction are called disproportionation reactions. e.g.



Q.9- Which metal in the first series of transition metals exhibits +1 oxidation state most frequently and why?

A.9- Copper with configuration [Ar] 3d¹⁰ 4s¹ exhibits +1 oxidation state. Copper loses 4s¹ electron easily and achieved a stable configuration 3d¹⁰ by forming Cu⁺.

Q.10- What are inner transition elements?

A.10- The f-block elements in which the last electron accommodated on (n-2) f-subshell are called inner transition elements. These include atomic numbers 58 to 71 and from 90 to 103.

Q.11- The paramagnetic character in 3d-transition series elements increases upto Mn and then decreases. Explain why?

A.11- In the 3d-transition series as we move from Sc (21) to Mn (25) the number of unpaired electrons increases and hence paramagnetic character increases. After Mn, the pairing of electrons in the d-orbital starts and the number of unpaired electrons decreases and hence, paramagnetic character decreases.

Q.12- Comment on the statement that elements of the first transition series possess many properties different from those of heavier transition metal

A.12-The following points justify that the given statement is true:-

(i) Ionization enthalpies of heavier transition elements are higher than the elements of 3d series. Consequently, heavier transition elements are less reactive in comparison to 3d-elements.

(ii) Melting points of heavier transition elements are higher than 3d-elements.

(iii) Higher oxidation states of heavier transition elements are stable whereas lower oxidation states are stable in 3d-elements.

Q.13-What are transition elements? Which d-block elements are not regarded as transition elements and why?

A.13- An element which has partially filled (n-1) d orbital is known as transition elements. Group 12 elements i.e. Zn, Cd, Hg have completely filled (n-1) d-orbital in atomic & ionic state & thus these elements are not considered as Transition Elements.

Q.14-What are interstitial compounds? Why are such compounds well known for transition metal?

A.14- Compounds of transition metal with relatively smaller non-metals are known as interstitial compounds. These compounds are well known for transition metals because size of C, N, O, and B is similar to size of interstitial voids of transition metal

Q.15-For the first row of transition metals the E^0 values are:-

E^0 values	V	Cr	Mn	Fe	Co	Ni	Cu
M^{2+}/M	-1.18	-0.91	-1.18	-0.44	-0.28	-0.25	+0.34

Explain the irregularity in the above values.

A.15-The $E^0 (M^{2+}/M)$ values are not regular which can be explained from the irregular variation of ionization energy and sublimation energy of Mn due to half-filled orbitals.

(THREE MARK QUESTIONS)

Q.1- Decide giving reason which one of the following pairs exhibits the property indicated:

- (i) Sc^{3+} or Cr^{3+} exhibits paramagnetism
- (ii) V or Mn exhibits more number of oxidation states
- (iii) V^{4+} or V^{5+} exhibits colour

A.1- (i) $Sc=[Ar] 3d^1 4s^2$; $Sc^{3+}=[Ar]$; it has no unpaired electron so diamagnetic
 $Cr=[Ar] 3d^5 4s^1$; $Cr^{3+}=[Ar] 3d^3$; it has three unpaired electrons paramagnetic
 (ii) $V=[Ar] 3d^3 4s^2$ $Mn=[Ar] 3d^5 4s^2$ Thus V exhibit oxidation states of +2, +3, +4, +5
 Whereas Mn exhibit oxidation states of +2 to +7.

(iii) $V^{4+}=[Ar] 3d^1 \rightarrow$ coloured $V^{5+}=[Ar] \rightarrow$ colourless

Q.2-(a) Describe the general trends in the following properties of the first series of the transition elements:-

- (i) Stability of +2-oxidation state
- (ii) Formation of oxometal ions

(b) Write steps involved in the preparation of $KMnO_4$ from K_2MnO_4

A.2- (a) i-The elements of first transition series show decreasing tendency to form divalent cation as we move left to right in the series. This trend is due to general increase in the first and second ionization energy. The greater stability of Mn^{2+} is due to half filled d^5 configuration and that of zinc is due to d^{10} configuration.

(ii) All metal except Sc from oxide of type MO which are basic. The highest oxidation number in all oxide, coincide with the group number and is attain in Sc_2O_3 to Mn_2O_7 . Formation of oxoanions is due to high electro negativity and small size of oxygen atom.

2-(b) It takes place in two steps:-

- (iii) Conversion of pyrolusite ore into potassium manganate.
- (iv) Conversion of potassium manganate to potassium permanganate.

Following reactions take place:-



Q.3-(a) Write the steps involve in the preparation of $K_2Cr_2O_7$ from chromite ore.

(b) What is the effect of pH on dichromate ion solution?

A.3-(a):- It takes place in three steps-

- (iv) Conversion of chromite ore to sodium chromate.
- (v) Conversion of sodium chromate to sodium dichromate.
- (vi) Conversion of sodium dichromate to potassium dichromate

Following reactions take place:-

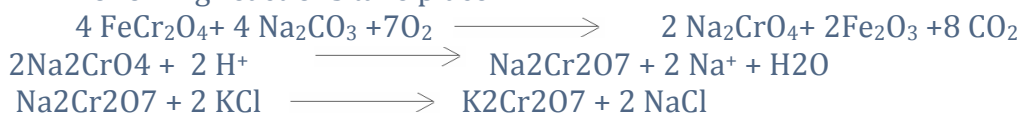

(b) Dichromate ion is orange in acidic solution (pH < 7) and turns yellow in basic solution. It is due to interconversion of dichromate ion to chromate ion. Following reactions take place:-



Q.4- (a) What is lanthanide contraction? What effect does it have on the chemistry of the elements, which follow lanthanoids?

(b) The chemistry of actinoid elements is not so much smooth as that of lanthanoids. Justify these statements by giving some examples from the oxidation state of these elements.

A.4- (a) The size of Lanthanoids and its trivalent ion decreases from La to Lu. It is known as lanthanoids contraction.

Cause: - It is due to poor shielding of 4f electrons.

Consequences of lanthanide contraction: - (i) Basic strength of hydroxide decreases from $\text{La}(\text{OH})_3$ to $\text{Lu}(\text{OH})_3$. (ii) Because of similar chemical properties lanthanides are difficult to separate.

(b) Lanthanoids show limited number of oxidation states i.e. +2, +3, +4 (out of which +3 is most common). This is because of a large energy gap between 4f, 5d and 6s subshell. The dominant oxidation state of actinides is also +3 but they show a number of other oxidation state also e.g. +4, +5, and +7. This is due to small energy difference between 5f, 6d and 7s orbitals.

Q.5- Give examples and suggest reasons for the following features of the transition metal chemistry:

(i) The lowest oxide of transition metal is basic, the highest is amphoteric/acidic.

(ii) A transition metal exhibits highest oxidation state in oxides and fluorides.

(iii) Of the d^4 species, Cr^{2+} is strongly reducing while manganese(III) is strongly oxidizing.

A.5-(i) The oxide of transition metals in lower oxidation states are generally basic while those in the higher oxidation states are acidic. Acidic character increases with increase in oxidation state is due to decrease in size of metal ion and increase in charge density. e.g. MnO (basic), Mn_3O_4 (amphoteric), Mn_2O_7 (acidic).

(ii) A transition metal exhibits higher oxidation states in oxides and fluorides because oxygen and fluorine are the most electronegative elements and thus easily can unpair electrons of metal atom.

(iii) Because oxidizing and reducing property depends on E^0 value. Since E^0 value of $\text{Cr}^{3+}/\text{Cr}^{2+}$ is negative while that of $\text{Mn}^{3+}/\text{Mn}^{2+}$ is positive, as a result $\text{Cr}(\text{II})$ act as reducing agent and $\text{Mn}(\text{III})$ is strong oxidizing.

Q.6- For M^{2+}/M and $\text{M}^{3+}/\text{M}^{2+}$ systems, the E^0 values for some metals are as follows:

Cr^{2+}/Cr	-0.9V	$\text{Cr}^{3+}/\text{Cr}^{2+}$	-0.4V
Mn^{2+}/Mn	-1.2V	$\text{Mn}^{3+}/\text{Mn}^{2+}$	+1.5V
Fe^{2+}/Fe	-0.4V	$\text{Fe}^{3+}/\text{Fe}^{2+}$	+0.8V

Use this data to comment upon :-

(i) the stability of Fe^{3+} in acid solution as compared to Cr^{3+} or Mn^{3+} and

(ii) the ease with which iron can be oxidized as compared to a similar process for either chromium or manganese metal.

A.6- (i) E^0 for $\text{Cr}^{3+}/\text{Cr}^{2+}$ is -0.4V i.e. negative, this means Cr^{3+} ions in the solution cannot be reduced to Cr^{2+} easily i.e. Cr^{3+} is stable. As $\text{Mn}^{3+}/\text{Mn}^{2+}$ is +1.5V i.e. positive means Mn^{3+} can easily be reduced to Mn^{2+} ions in comparison to Fe^{3+} ions. Thus relative stability of these ions is:-



(ii) The oxidation potentials for the given pairs will be +0.9V, +1.2V and 0.4V. Thus, the order of their getting oxidized will be in the order $\text{Mn} > \text{Cr} > \text{Fe}$.

Q.7- Account for the following statements:

(i) Cobalt (II) is stable in aqueous solution but in the presence of strong ligands and air, it can be oxidized to Co (III).

(ii) The d^1 configuration is very unstable in ions.

(iii) One among the lanthanides, Ce (III) can be easily oxidized to Ce (IV).

A.7- (i) Strong ligands force cobalt (II) to lose one more electron from 3d-subshell and thereby induced d^2sp^3 hybridisation.

(ii) The ion with d^1 configuration try to lose the only electron in order to acquire inert gas configuration.

(iii) The configuration of Ce is $[\text{Xe}] 4f^1, 5d^1, 6s^2$. There is no much difference between the energy of 4f, 5d and 6s orbitals and thus, Ce can utilize electrons present in these orbitals and hence oxidation state of +4.

Q.8- Compare the chemistry of actinides with that of the lanthanoids with special reference to:

- (i) electronic configuration (iii) oxidation state
(ii) atomic and ionic sizes and (iv) chemical reactivity

A.8-

Comparison of Lanthanoids and Actinides

Properties	Lanthanoids	Actinides
Electronic configuration	$[\text{Xe}] 4f^{1-14}, 5d^{0-1}, 6s^2$	$[\text{Rn}] 5f^{1-14}, 6d^{0-1}, 7s^2$
Atomic/ionic sizes	Size decreases from La to Lu, and size is more than actinides.	Size decreases from Ac to Lw, and size is smaller than lanthanoids due to poorer shielding of 5f electrons
Oxidation states	Common oxidation is +3 where other oxidation states are +2, +4. It is due to a large energy gap between 4f, 5d and 6s subshell	Common oxidation is +3 where other oxidation states are +2, +4, +5 and +7 due to small energy difference between 5f, 6d and 7s orbitals
Chemical reactivity	The earlier member quite reactive but with increasing atomic number they behave like aluminum.	The actinides highly reactive, especially in finely divided.
Complex formation	Less tendency to form complex due to less charge density.	More tendency to form complex due to high charge density.

Q.9-(a) What is actinides contraction? What effect does it have on the chemistry of the elements, which follow actinides?

(b) Name an important alloy, which contains some of the lanthanide metals. Mention its uses.

A.9- (a) The size of actinoid and its trivalent ion decreases from Ac to Lw. It is known as actinides contraction.

Cause: - It is due to poor shielding of 5f electrons.

Consequences of actinides contraction: - (i) Basic strength of hydroxide decreases from $\text{Ac}(\text{OH})_3$ to $\text{Lw}(\text{OH})_3$. (ii) Because of similar chemical properties actinides are difficult to separate.

(b) An important alloy containing lanthanoid metals is mischmetal, which contains 95% lanthanide metal and 5% Fe along with traces of S, C, Ca and Al. It is used in Mg-based alloy to produce bullets, shells and lighter flint.

Q.10- Complete following reactions:-



(FIVE MARK QUESTIONS)

Q.1- Explain giving reasons:

- (i) Transition metals and many of their compounds show paramagnetic behaviour.

- (ii) The enthalpies of atomisation of the transition metals are high.
- (iii) The transition metals generally form coloured compounds.
- (iv) Transition metals and their many compounds act as good catalyst.
- (v) Transition metals have a strong tendency to form complexes.

A.1- (i) Transition metals and many of their compounds show paramagnetic behaviour due to presence of unpaired electrons in (n-1) d orbital.

- (ii) The enthalpies of atomisation of the transition metals are high Because of large number of unpaired electrons in their atoms, they have stronger interatomic interaction and hence strong metallic bonding is present between atoms.
- (iii) The transition metals generally form coloured compounds due to presence of unpaired electrons in (n-1) d orbital & thus they can undergo d-d transition.
- (iv) Transition metals and their many compounds act as good catalyst It is due to (i) partially filled (n-1) d orbital (ii) Variable oxidation state (iii) Ability to change oxidation state frequently.
- (v) Transition metals have a strong tendency to form complexes Most of transition elements form complex compounds due to (i) small size (ii) high charge (iii) presence of vacant d-orbital of suitable energy.

Q.2- Give reasons for the following:-

- (i) Fe has higher melting point than Cu.
- (ii) $[\text{Ti}(\text{H}_2\text{O})_6]^{3+}$ is coloured while $[\text{Sc}(\text{H}_2\text{O})_6]$ is colourless.
- (iii) The 4d and 5d series of transition metals have more frequent metal-metal bonding in their compound than do the 3d metals.
- (iv) Transition metals some time exhibit very low oxidation state such as +1 and 0.
- (v) Hg is not considered a transition metal.

A.2-(i) This is because Fe ($3d^6, 4s^1$) has four unpaired electrons in 3d-subshell. While Cu ($3d^{10}, 4s^1$) only one unpaired electron in 4s shell. Hence metallic bonding is stronger in Fe than those in Cu.

(ii) The oxidation state of Ti in $[\text{Ti}(\text{H}_2\text{O})_6]^{3+}$ is +3 and its configuration is $[\text{Ar}] 3d^1$ i.e one unpaired electron and hence it is coloured. Whereas the oxidation state of Sc in $[\text{Sc}(\text{H}_2\text{O})_6]^{3+}$ is +3 and its configuration is $[\text{Ar}] 3d^0$ i.e no unpaired electron and hence it is colourless.

(iii) In the same group of d-block elements, the 4d and 5d transition elements are larger size than that of 3d elements. Hence, the valence electrons are less tightly held and form metal-metal bond more frequently.

(iv) +1 oxidation state is shown by elements like Cu because after loss of one electron, it acquire stable configuration. Zero oxidation state is shown in metal carbonyl, because π -electrons donated by CO are accepted into the empty orbital.

(v) The characteristic properties of transition metal are due to partially filled d-orbitals. Hg has completely filled d-orbital, as a result it doesn't show properties of transition metals and hence is not considered as transition metal.

Q.3-(a) write electronic configuration of element having atomic number 101.

- (b) Which element show maximum oxidation state in 3d transition series?
- (c) What is mischmetal?
- (d) Explain why Cu^+ ion is not stable in aqueous solution?
- (e) Name the transition metal which is well known to exhibit +4 oxidation state?

A.3-(a) $[\text{Rn}] 5f^{13}, 6d^0, 7s^2$.

(b) Mn, Which shows +7 oxidation state in KMnO_4 .

(c) It is an important alloy, which contains 95% lanthanide metal and 5% Fe along with traces of S, C, Ca and Al. It is used in Mg-based alloy to produce bullets, shells and lighter flint.

(d) Water is a good complexing agent and thus Cu forms complex by losing one more electron from 3d orbital.

(e) Cerium (Z=58)

Q.4-(a) Write the preparation of potassium dichromate from iron chromite. What happens when potassium dichromate reacts with (i) Hydrogen sulphide (ii) FeSO_4 ?

- (b) Why do Zr and Hf exhibit almost similar properties?
- (c) Why is $\text{La}(\text{OH})_3$ stronger base than $\text{Lu}(\text{OH})_3$.

A.4- (a) Preparation:- It takes place in three steps-

- (i) Conversion of chromite ore to sodium chromate.
- (ii) Conversion of sodium chromate to sodium dichromate.
- (iii) Conversion of sodium dichromate to potassium dichromate

Following reaction takes place:-

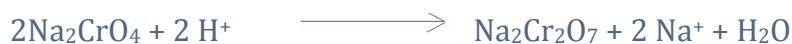

Reactions: - (i) $\text{Cr}_2\text{O}_7^{2-} + 8 \text{H}^+ + 3 \text{H}_2\text{S} \rightarrow 2\text{Cr}^{3+} + 7 \text{H}_2\text{O} + 3\text{S}$

(ii) $\text{Cr}_2\text{O}_7^{2-} + 14 \text{H}^+ + 6 \text{Fe}^{2+} \rightarrow 2\text{Cr}^{3+} + 7 \text{H}_2\text{O} + 6 \text{Fe}^{3+}$.

(b) Because both have similar ionic size

(c) Due to lanthanoid contraction size of La^{3+} is smaller than Lu^{3+} as a result Lu-O bond will be stronger than La-O bond.

Q.5- Give reasons for the following:-

(i) Transition metals have high enthalpy of hydration.

(ii) Zn, Cd and Hg are not regarded as transition metal.

(iii) d block elements exhibit a large number of oxidation states than f block elements.

(iv) The second and third members in each group of transition elements have similar atomic radii.

(v) $\text{K}_2[\text{PtCl}_6]$ is a well known compound whereas the corresponding Ni compound is not known.

A.5-(i) Transition metal ions are smaller and have higher charge, therefore they have high enthalpy of hydration.

(ii) Group 12 elements i.e. Zn, Cd, Hg have completely filled (n-1) d-orbitals in atomic & ionic state & thus these elements are not considered as transition elements.

(iii) The difference in the energy of (n-1) d orbital and ns orbital is very small and thus both subshells are used for bond formation. Whereas in f block elements (n-2)f orbitals lie underneath and hence are not available for bond formation.

(iv) The second and third members in each group of transition elements have similar atomic radii due to lanthanoid contraction. It arises due to poor shielding of d and f electrons.

(v) The oxidation state of Pt is +4 which is stable for Pt. The +4 oxidation state for Ni is very difficult to achieve because the sum of the first four ionization energies is very high. Hence, the corresponding Ni(II) compound is known.

UNIT 9: CO-ORDINATION COMPOUNDS

The compounds which contain dative bonds between metal atom and surrounding species is called co-ordination compounds

The branch of inorganic chemistry which deals with the study of preparation properties of coordination compound is called co-ordination chemistry.



POINTS TO REMEMBER:

1. Coordination compounds

Coordination compounds are compounds in which a central metal atom or ion is linked to a number of ions or neutral molecules by coordinate bonds or which contain complex ions.

Examples- $K_4[Fe(CN)_6]$; $[Cu(NH_3)_4]SO_4$; $Ni(CO)_4$

2. The main postulates of Werner's theory of coordination compounds

- i) In coordination compounds metals show two types of linkages or valencies- Primary and Secondary.
- ii) The primary valencies are ionisable and are satisfied by negative ions.
- iii) The secondary valencies are non- ionisable and are satisfied by neutral molecules or negative ions. The secondary valence is equal to the C.N and is fixed for a metal.
- iv) The ions or groups bound by secondary linkages to the metal have characteristic spatial arrangements corresponding to different coordination nos.

3. Difference between a double salt and a complex

Both double salts as well as complexes are formed by the combination of two or more stable compounds in stoichiometric ratio. However, double salts such as carnallite, $KCl.MgCl_2.6H_2O$, Mohr's salt, $FeSO_4.(NH_4)_2SO_4.6H_2O$, potash alum, $KAl(SO_4)_2.12H_2O$, etc. dissociate into simple ions completely when dissolved in water. However, complex ions such as $[Fe(CN)_6]^{4-}$ of $K_4[Fe(CN)_6]$, do not dissociate into Fe^{2+} and CN^- ions.

IMPOTANT TERMINOLOGY

(i) **Coordination entity:** It constitutes the central metal ion or atom bonded to a fixed number of ions or molecules represented within a square bracket.

(ii) **Central atom/ ion:** In a coordination entity, the atom/ion to which a fixed number of ions/groups are bound in a definite geometrical arrangement around it, is called the central atom or ion.

iii) **Ligands:** The neutral or negative ions bound to the central metal or

ion in the coordination entity. These donate a pair/s of electrons to the central metal atom /ion. Ligands may be classified as-

- a) **Monodentate/Unidentate:** Ligands bound to the central metal atom/ion through a single donor atom. Ex- Cl^- ; H_2O ; NH_3 ; NO_2^- .
- b) **Didentate:** Ligates through two donor atoms. Ex- $\text{C}_2\text{O}_4^{2-}$ (ox); $\text{H}_2\text{NCH}_2\text{CH}_2\text{NH}_2$ (en)
- c) **Polydentate:** which ligates through two or more donor atoms present in a single ligand. Ex- $(\text{EDTA})^{4-}$
- d) **Chelating ligands:** Di- or polydentate ligands that uses two or more donor atoms to bind to a single metal ion to form ring- like complexes. (Ox); (edta)
- e) **Ambidentate ligand:** A ligand that can ligate through two different atoms, one at a time. Ex- NO_2^- ; SCN^-
- v) **Coordination number:** The no. of ligand donor atoms to which the metal is directly bonded through sigma bonds only. It is commonly 4 or 6.
- vi) **Counter ions:** The ionisable groups written outside the square bracket. Ex- K^+ in $\text{K}_4[\text{Fe}(\text{CN})_6]$ OR 3Cl^- in $[\text{Co}(\text{NH}_3)_6]\text{Cl}_3$
- vii) **Coordination Polyhedron:** The spatial arrangement of the ligand atoms which are directly attached to the central metal atom/ion. They are commonly Octahedral, Square-planar or Tetrahedral
Oxidation number: The charge that the central atom would carry if all the ligands are removed along with their pairs of electrons shared with the central atom. It is represented in parenthesis.
- viii) **Homoleptic complexes:** Complexes in which a metal is bonded to only one kind of donor groups. Ex- $[\text{Co}(\text{NH}_3)_6]^{3+}$
- ix) **Heteroleptic complexes:** Complexes in which a metal is bonded to more than one kind of donor groups. Ex- $[\text{Co}(\text{NH}_3)_4\text{Cl}_2]^+$

5. NAMING OF MONONUCLEAR COORDINATION COMPOUNDS

The principle of additive nomenclature is followed while naming the coordination compounds. The following rules are used-

- i The cation is named first in both positively and negatively charged coordination entities.
- ii The ligands are named in an alphabetical order before the name of the central atom/ion

- iii The name of the anionic ligands end in -o, those of neutral and cationic ligands are the same except aqua for H₂O, ammine for NH₃, carbonyl for CO and nitrosyl for NO. these are placed within enclosing marks .
- iv When the prefixes mono, di, tri, etc., are used to indicate the number of the individual ligands in the coordination entity. When the names of the ligands include a numerical prefix, then the terms, bis, tris , tetrakis are used, the ligand to which they refer being placed in parenthesis.
- v Oxidation state of the metal in cation, anion, or neutral coordination entity is indicated by roman numeral in parenthesis.
- vi If the complex ion is a cation , the metal is same as the element.
- vii The neutral complex molecule is named similar to that of the complex cation.

KRISHNA
PUBLIC SCHOOL

6.NAMES OF SOME COMMON LIGANDS

NEGATIVE LIGANDS		CHARGE	NEUTRAL LIGANDS		CHARGE
CN-	Cyano	-1	NH ₃	Ammine	0
Cl-	Chlorido	-1	H ₂ O	Aqua/aquo	0
Br-	Bromido	-1	NO	Nitrosyl	0

F ⁻	Fluoride	-1	CO	Carbonyl	0
SO ₄ ²⁻	Sulphato	-2	PH ₃	Phosphine	0
C ₂ O ₄ ²⁻	Oxalato	-4	CH ₂ -NH ₂ CH ₂ NH ₂	(1,2-Ethane diamine)	0
NH ₂ ⁻	Amido	-1	POSITIVE LIGANDS		
NH ₂ ⁻	Imido	-2	NH ₂ -NH ₃ ⁺	Hydrazinium	+1
ONO ⁻	Nitrito-O	-1	NO ⁺	Nitrosonium	+1
NO ₂ ⁻	Nitro	-1	NO ₂ ⁺	Nitronium	+1
NO ₃ ⁻	Nitrato	-1			
SCN ⁻	Thiocyanato	-1			
NCS ⁻	Isothiocyanato	-1			
CH ₂ (NH ₂)COO ⁻	Glycinato	-1			

-OH	Hydroxo	-1			
-----	---------	----	--	--	--

KRISHNA
PUBLIC SCHOOL

7. ISOMERISM IN COORDINATION COMPOUNDS

Two or more substances having the same molecular formula but different spatial arrangements are called isomers and the phenomenon is called isomerism. Coordination compounds show two main types of isomerism-

A) Structural Isomerism

B) Stereoisomerism

STRUCTURAL ISOMERISM:- It arises due to the difference in structures of coordination compounds. It is further subdivided into the following types-

1) **Ionisation isomerism :** This form of isomerism arises when the counter ion in a complex salt is itself a potential ligand and can displace a ligand which can then become the counter ion. An example is provided by the ionization isomers $[\text{Co}(\text{NH}_3)_5\text{SO}_4]\text{Br}$ and $[\text{Co}(\text{NH}_3)_5\text{Br}]\text{SO}_4$.

2) **Hydrate or solvate isomerism:** This form of isomerism is known as 'hydrate isomerism' in case where water is involved as a solvent. This is similar to ionisation isomerism. Solvate isomers differ by whether or not a solvent molecule is directly bonded to the metal ion or merely present as free solvent molecules in the crystal lattice. An example is provided by the aqua complex $[\text{Cr}(\text{H}_2\text{O})_6]\text{Cl}_3$ (violet) and its solvate isomer $[\text{Cr}(\text{H}_2\text{O})_5\text{Cl}]\text{Cl}_2 \cdot \text{H}_2\text{O}$ (grey-green).

3) **Linkage Isomerism:** Linkage isomerism arises in a coordination compound containing ambidentate ligand. A simple example is provided by complexes containing the thiocyanate ligand, NCS -, which may bind through the nitrogen to give $\text{M}-\text{NCS}$ or through sulphur to give $\text{M}-\text{SCN}$.

4) **Coordination isomerism:** It arises from the interchange of ligands between cationic and anionic entities of different metal ions present in a complex .
Example $[\text{Co}(\text{NH}_3)_6][\text{Cr}(\text{CN})_6]$ & $[\text{Cr}(\text{NH}_3)_6][\text{Co}(\text{CN})_6]$

STEREOISOMERISM: Stereo isomers have the same chemical formula and chemical bonds but they have different spatial arrangement. They are of two kinds

A. Geometrical isomerism

B. Optical isomerism

GEOMETRICAL ISOMERISM- This type of isomerism arises in heteroleptic complexes due to different possible geometric arrangements of the ligands. Important examples of this behaviour are found with coordination numbers 4 and 6. In a square planar complex of formula $[\text{MX}_2\text{L}_2]$ (X and L are unidentate), the two ligands X may be arranged adjacent to each other in a cis isomer, or opposite to each other in a trans isomer $[\text{MABXL}]$ -Where A,B,X,L are unidentates
Two cis- and one trans- isomers are possible.

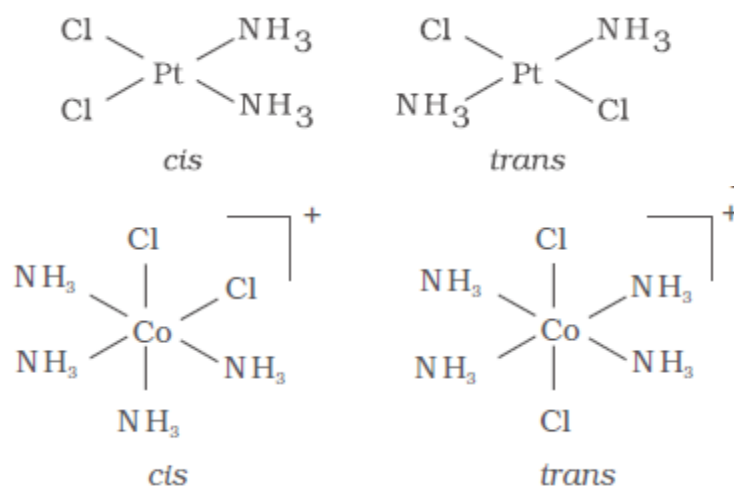

Another type of geometrical isomerism occurs in octahedral coordination entities of the type $[Ma_3b_3]$ like $[Co(NH_3)_3(NO_2)_3]$. If three donor atoms of the same ligands occupy adjacent positions at the corners of an octahedral face, we have the facial (fac) isomer. When the positions are around the meridian of the octahedron, we get the meridional (mer) isomer.

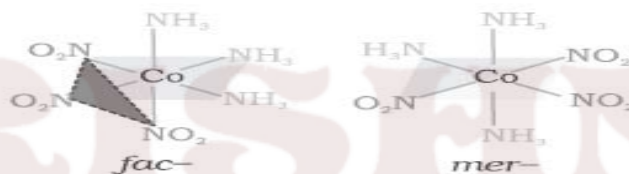

b) **OPTICAL ISOMERISM:** Optical isomers are mirror images that cannot be superimposed on one another. These are called as enantiomers. The molecules or ions that cannot be superimposed are called chiral. The two forms are called dextro (d) and laevo (l) depending upon the direction they rotate the plane of polarised light in a polarimeter (d rotates to the right, l to the left). Optical isomerism is common in octahedral complexes involving didentate ligands. In a coordination entity of the type $[CoCl_2(en)_2]^{2+}$, only the cis-isomer shows optical activity

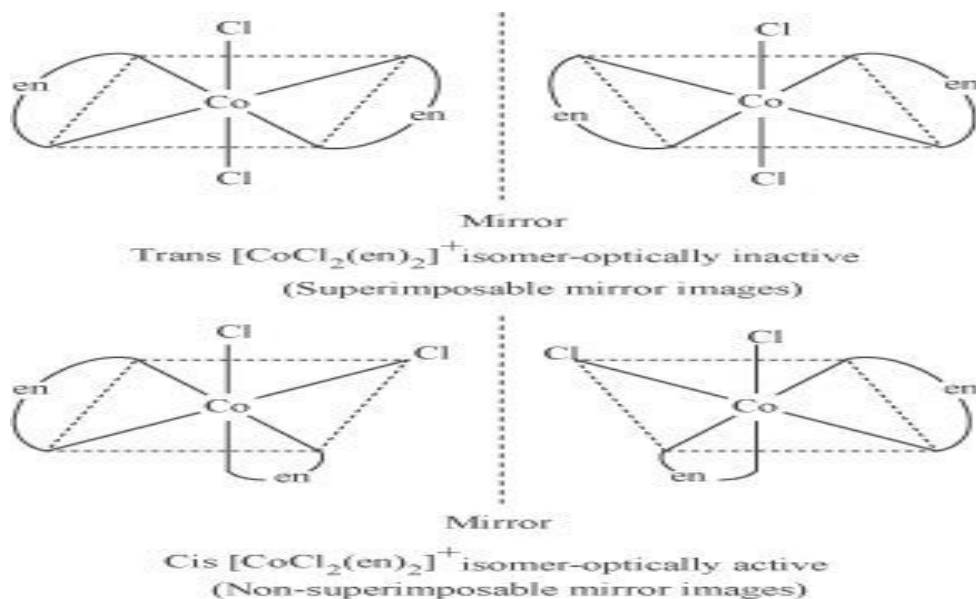

TYPES OF HYBRIDISATION

Coordination number	Type of hybridisation	Acquired geometry
4	sp^3	Tetrahedral
4	dsp^2	Square planar
5	sp^3d	Trigonal bipyramidal
6	sp^3d^2	Octahedral
6	d^2sp^3	Octahedral

8. CRYSTAL FIELD THEORY:

1. The metal-ligand bond is ionic arising purely from electrostatic interactions between the metal ion and the ligand.
2. Ligands are treated as point charges or dipoles in case of anions and neutral molecules.
3. In an isolated gaseous metal atom or ion the five d-orbitals are degenerate.
4. Degeneracy is maintained if a spherically symmetrical field of negative charges surrounds the metal /ion.
5. In a complex the negative field becomes asymmetrical and results in splitting of the

d-orbitals.

A) CRYSTAL FIELD SPLITTING IN OCTAHEDRAL COORDINATION ENTITIES

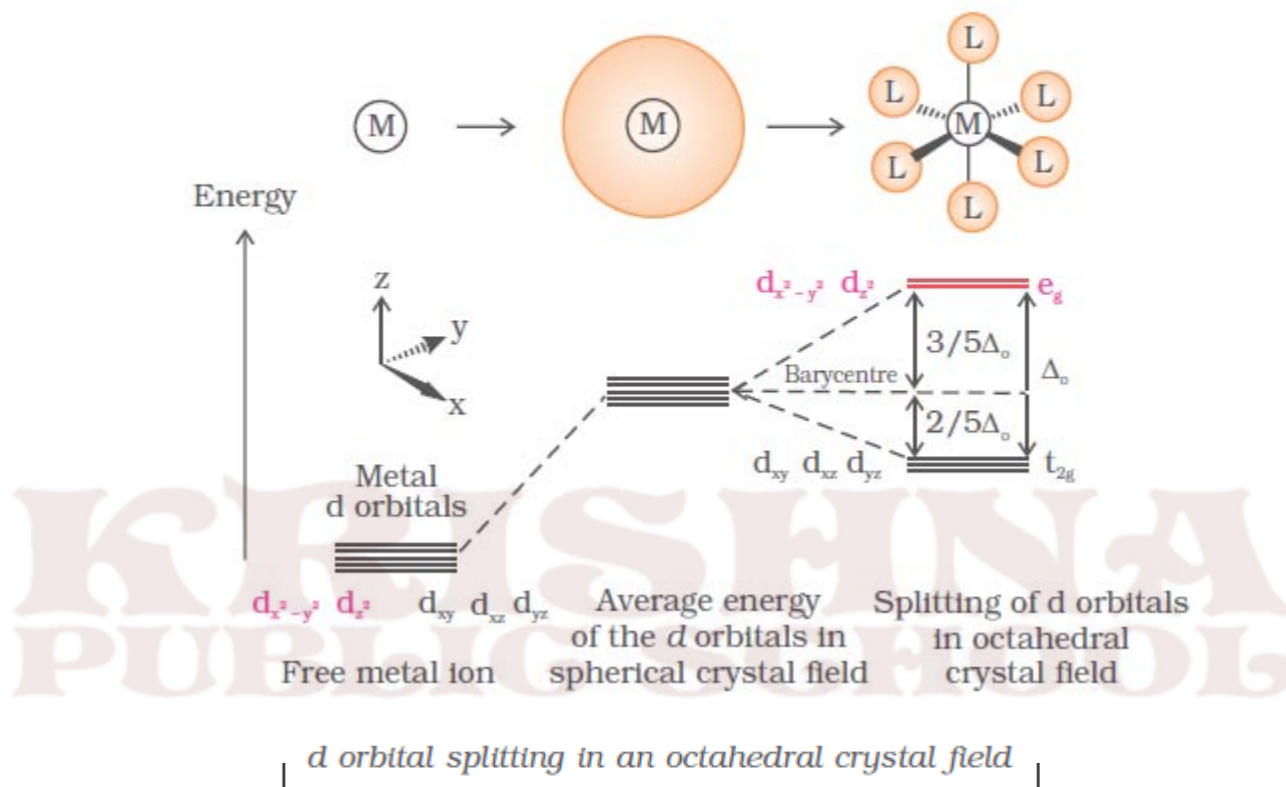

1. For d^4 ions, two possible patterns of electron distribution arise:

(i) If $\Delta_o < P$, the fourth electron enters one of the e_g orbitals giving the

configuration $t^3_{2g} e^1_g$. Ligands for which $\Delta_o < P$ are known as weak

field ligands and form high spin complexes.

(ii) If $\Delta_o > P$, it becomes more energetically favourable for the fourth electron to occupy a t_{2g} orbital with configuration $t^4_{2g} e^0_g$. Ligands which produce this effect are known as strong field ligands and form low spin complexes.

B) CRYSTAL FIELD SPLITTING IN TETRAHEDRAL COORDINATION ENTITIES

1. The four surrounding ligands approach the central metal atom/ion along the planes between the axes.

2. The t_{2g} orbitals are raised in energy $(2/5) \Delta_t$.

3. The two e_g orbitals are lowered in energy $(3/5) \Delta_t$.

4. The splitting is smaller as compared to octahedral field splitting, $\Delta_t = (4/9) \Delta_o$.

5. Pairing of electrons is rare and thus complexes have generally high spin configurations.

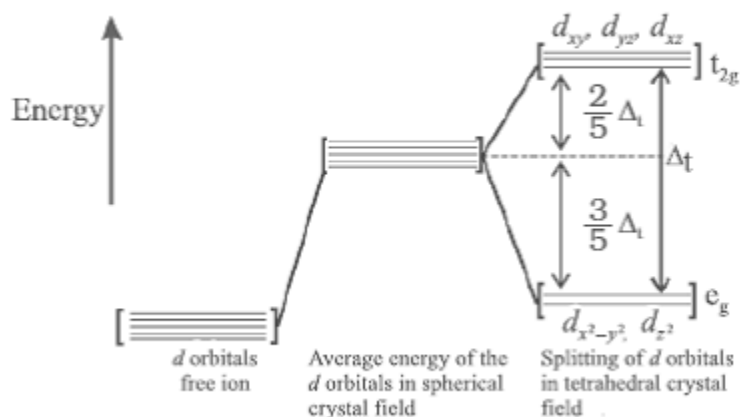

BONDING IN METAL CARBONYLS

The metal-carbon bond in metal carbonyls possess both σ and π character. The M-C σ bond

is formed by the donation of lone pair of electrons on the carbonyl carbon into a vacant orbital of the metal. The M-C π bond is formed by the donation of a pair of electrons from a filled d orbital of metal into the vacant antibonding π^* orbital of carbon monoxide. The metal to ligand bonding creates a synergic effect which strengthens the bond between CO and the metal.

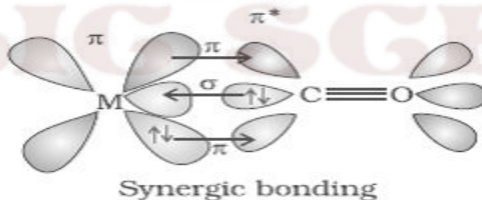

SOLVED QUESTIONS

1 MARK QUESTIONS

1. What are ambidentate ligands? Give two examples for each.

ANS. Ambidentate ligands are ligands that can attach themselves to the central metal atom through two different atoms. For example:



(The donor atom is N)

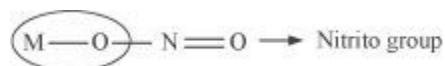

(The donor atom is oxygen)



(The donor atom is S)



(The donor atom is N)

Q2. Using IUPAC norms write the formula for the following: Tetrahydroxozincate(II)

ANS. $[\text{Zn}(\text{OH})_4]^{2-}$

Q3. Using IUPAC norms write the formula for the following: Hexaamminecobalt(III) sulphate

ANS. $[\text{Co}(\text{NH}_3)_6]_2 (\text{SO}_4)_3$

Q4. Using IUPAC norms write the formula for the following: Pentaamminenitrito-O-cobalt(III)

ANS. $[\text{Co}(\text{ONO}) (\text{NH}_3)_5]^{2+}$

Q5. Using IUPAC norms write the systematic name of the following: $[\text{Co}(\text{NH}_3)_6]\text{Cl}_3$

ANS. Hexaamminecobalt(III) chloride

Q6. Using IUPAC norms write the systematic name of the following:

$[\text{Pt}(\text{NH}_3)_2\text{Cl}(\text{NH}_2\text{CH}_3)]\text{Cl}$

ANS. Diamminechlorido(methylamine) platinum(II) chloride

Q7. Using IUPAC norms write the systematic name of the following: $[\text{Co}(\text{en})_3]^{3+}$

ANS. Tris(ethane-1, 2-diammine) cobalt(III) ion

Q8. Draw the structures of optical isomers of: $c[\text{Cr}(\text{C}_2\text{O}_4)_3]^{3-}$

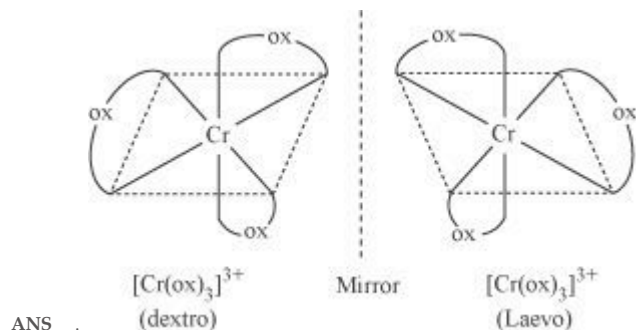

Q9. What is meant by the chelate effect? Give an example.

ANS. When a ligand attaches to the metal ion in a manner that forms a ring, then the metal-ligand association is found to be more stable.

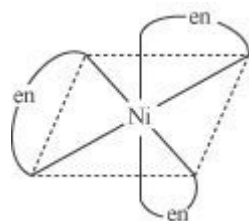

2 / 3 MARK QUESTIONS

Q1. What is spectrochemical series? Explain the difference between a weak field ligand and a strong field ligand.

ANS. A spectrochemical series is the arrangement of common ligands in the increasing order of their crystal-field splitting energy (CFSE) values.

$I^- < Br^- < S_2^{2-} < SCN^- < Cl^- < N_3^- < F^- < OH^- < C_2O_4^{2-} \sim H_2O < NCS^- \sim H^- < CN^- < NH_3 < en \sim SO_3^{2-} < NO_2^- < phen < CO$

Q2. $[Cr(NH_3)_6]^{3+}$ is paramagnetic while $[Ni(CN)_4]^{2-}$ is diamagnetic. Explain why?

ANS. Cr is in the +3 oxidation state i.e., d^3 configuration. Also, NH_3 is a weak field ligand that does not cause the pairing of the electrons in the 3d orbital.



Therefore, it undergoes d^2sp^3 hybridization and the electrons in the 3d orbitals remain unpaired. Hence, it is paramagnetic in nature.

In $[Ni(CN)_4]^{2-}$, Ni exists in the +2 oxidation state i.e., d^8 configuration.



CN^- is a strong field ligand. It causes the pairing of the 3d orbital electrons. Then, Ni^{2+} undergoes dsp^2 hybridization.

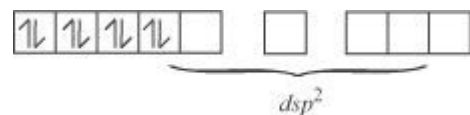

Q3. A solution of $[Ni(H_2O)_6]^{2+}$ is green but a solution of $[Ni(CN)_4]^{2-}$ is colourless. Explain.

ANS. In $[Ni(H_2O)_6]^{2+}$, $H_2\ddot{O}$ is a weak field ligand. Therefore, there are unpaired electrons in Ni^{2+} . In this complex, the d electrons from the lower energy level can be excited to the higher energy level i.e., the possibility of d-d transition is present. Hence, $[Ni(H_2O)_6]^{2+}$ is coloured.

In $[\text{Ni}(\text{CN})_4]^{2-}$, the electrons are all paired as CN^- is a strong field ligand. Therefore, d-d transition is not possible in $[\text{Ni}(\text{CN})_4]^{2-}$. Hence, it is colourless. As there are no unpaired electrons, it is diamagnetic.

Q2. Draw all the isomers (geometrical and optical) of:

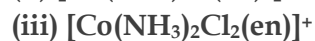
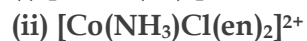

ANS. (i) $[\text{CoCl}_2(\text{en})_2]^+$

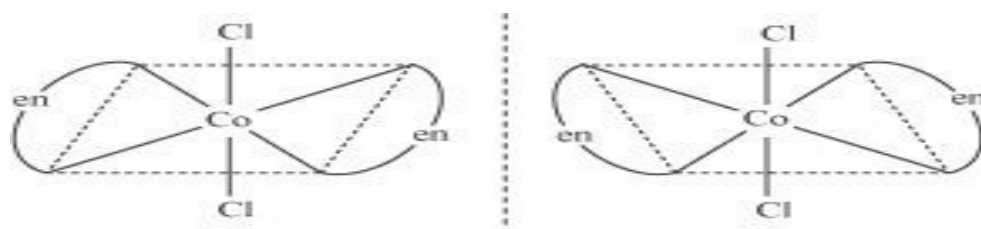

Trans $[\text{CoCl}_2(\text{en})_2]^+$ isomer—optically inactive
(Superimposable mirror images)

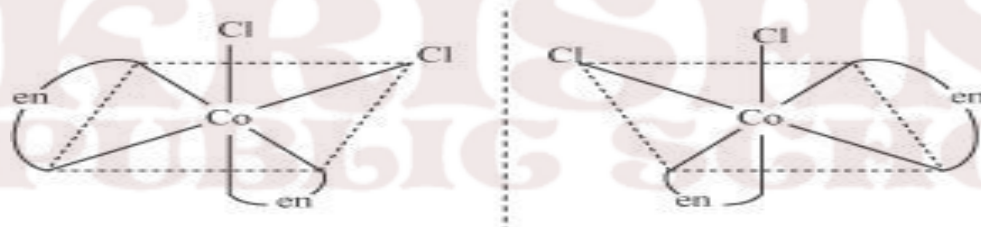

Cis $[\text{CoCl}_2(\text{en})_2]^+$ isomer—optically active
(Non-superimposable mirror images)

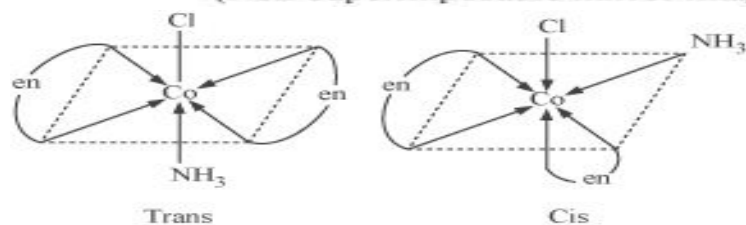

Trans

Cis

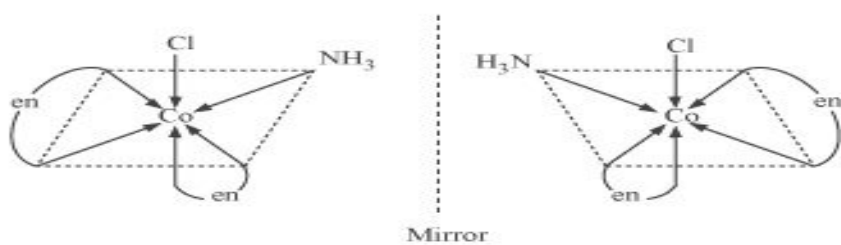

Mirror

In total, three isomers are possible.

Trans-isomers are optically inactive.

Cis-isomers are optically active.

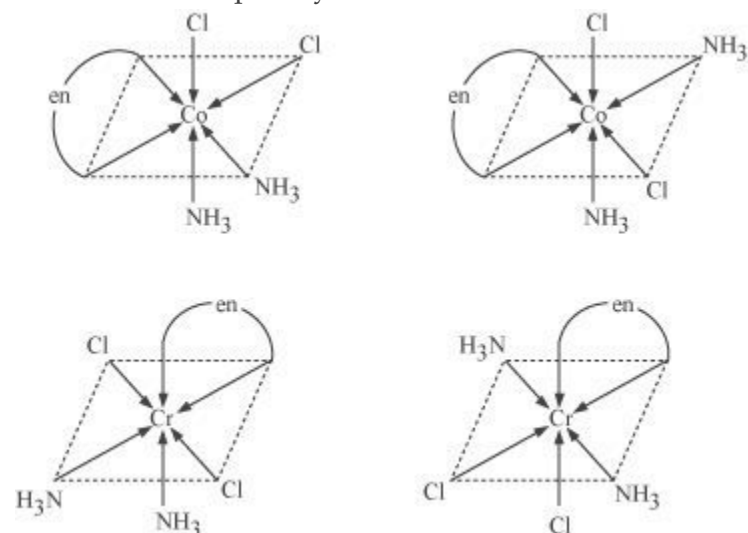

(iii) $[\text{Co}(\text{NH}_3)_2\text{Cl}_2(\text{en})]^+$

Q3. Write all the geometrical isomers of $[\text{Pt}(\text{NH}_3)(\text{Br})(\text{Cl})(\text{py})]$ and how many of these will exhibit optical isomers?

ANS. $[\text{Pt}(\text{NH}_3)(\text{Br})(\text{Cl})(\text{py})]$

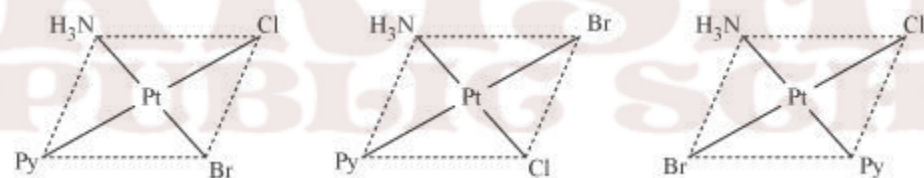

From the above isomers, none will exhibit optical isomers. Tetrahedral complexes rarely show optical isomerization. They do so only in the presence of unsymmetrical chelating agents.

Q4. What is meant by stability of a coordination compound in solution? State the factors which govern stability of complexes.

ANS. The stability of a complex in a solution refers to the degree of association between the two species involved in a state of equilibrium. Stability can be expressed quantitatively in terms of stability constant or formation constant.

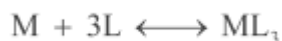

$$\text{Stability constant, } \beta = \frac{[\text{ML}_3]}{[\text{M}] [\text{L}]^3}$$

For this reaction, the greater the value of the stability constant, the greater is the proportion of ML_3 in the solution.

5 MARKS QUESTIONS

Q1. (a) Discuss the nature of bonding in the following coordination entities on the basis of valence bond theory:

(i) $[\text{Fe}(\text{CN})_6]^{4-}$ (ii) $[\text{FeF}_6]^{3-}$ (iii) $[\text{Co}(\text{C}_2\text{O}_4)_3]^{3-}$ (iv) $[\text{CoF}_6]^{3-}$

ANS. (i) $[\text{Fe}(\text{CN})_6]^{4-}$ In the above coordination complex, iron exists in the +II oxidation state. Fe^{2+} : Electronic configuration is $3d^6$ Orbitals of Fe^{2+} ion:



As CN^- is a strong field ligand, it causes the pairing of the unpaired $3d$ electrons. Since there are six ligands around the central metal ion, the most feasible hybridization is d^2sp^3 . d^2sp^3 hybridized orbitals of Fe^{2+} are:

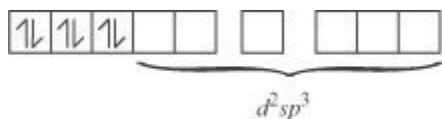

6 electron pairs from CN^- ions occupy the six hybrid d^2sp^3 orbitals. Then,

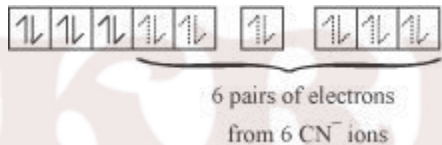

Hence, the geometry of the complex is octahedral and the complex is diamagnetic (as there are no unpaired electrons).

(ii) $[\text{FeF}_6]^{3-}$

In this complex, the oxidation state of Fe is +3.

Orbitals of Fe^{+3} ion:

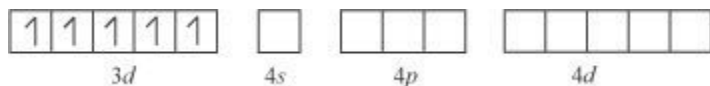

There are 6 F^- ions. Thus, it will undergo d^2sp^3 or sp^3d^2 hybridization. As F^- is a weak field ligand, it does not cause the pairing of the electrons in the $3d$ orbital. Hence, the most feasible hybridization is sp^3d^2 . sp^3d^2 hybridized orbitals of Fe are:

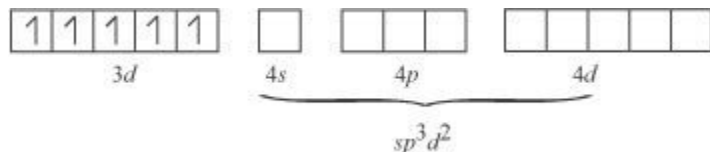

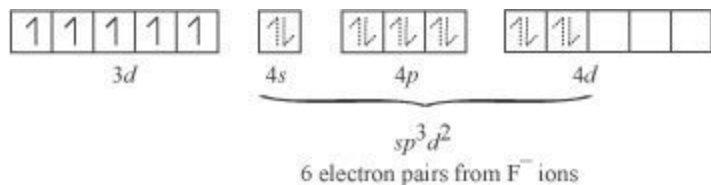

Hence, the geometry of the complex is found to be octahedral.

(iii) $[Co(C_2O_4)_3]^{3-}$

Cobalt exists in the +3 oxidation state in the given complex. Orbitals of Co^{3+} ion: Oxalate is a weak field ligand. Therefore, it cannot cause the pairing of the 3d orbital electrons. As there are 6 ligands, hybridization has to be either sp^3d^2 or d^2sp^3 hybridization. sp^3d^2 hybridization of Co^{3+} :

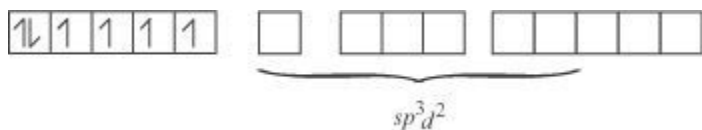

The 6 electron pairs from the 3 oxalate ions (oxalate anion is a bidentate ligand) occupy these sp^3d^2 orbitals.

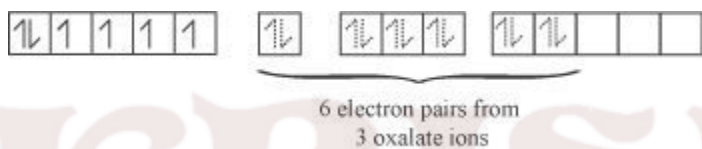

Hence, the geometry of the complex is found to be octahedral.

(iv) $[CoF_6]^{3-}$ -Cobalt exists in the +3 oxidation state.

Orbitals of Co^{3+} ion:

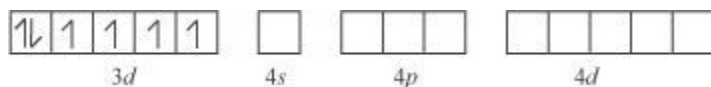

Again, fluoride ion is a weak field ligand. It cannot cause the pairing of the 3d electrons. As a result, the Co^{3+} ion will undergo sp^3d^2 hybridization. sp^3d^2 hybridized orbitals of Co^{3+} ion are:

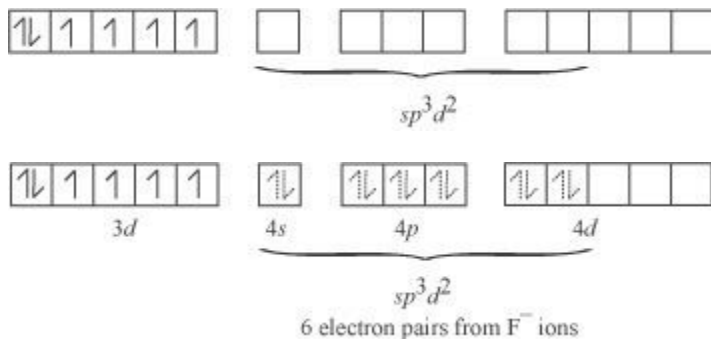

Hence, the geometry of the complex is octahedral and paramagnetic.

Q3. Write down the IUPAC name for each of the following complexes and indicate the oxidation state, electronic configuration and coordination number. Also give stereochemistry and magnetic moment of the complex:

(i) $K[Cr(H_2O)_2(C_2O_4)_2] \cdot 3H_2O$ (ii) $[Co(NH_3)_5Cl]Cl_2$ ANS. (i) Potassium diaquadioxalatochromate (III) trihydrate.

Oxidation state of chromium = 3

Electronic configuration: $3d^3: t_{2g}^3$

Coordination number = 6

Shape: octahedral

Stereochemistry:

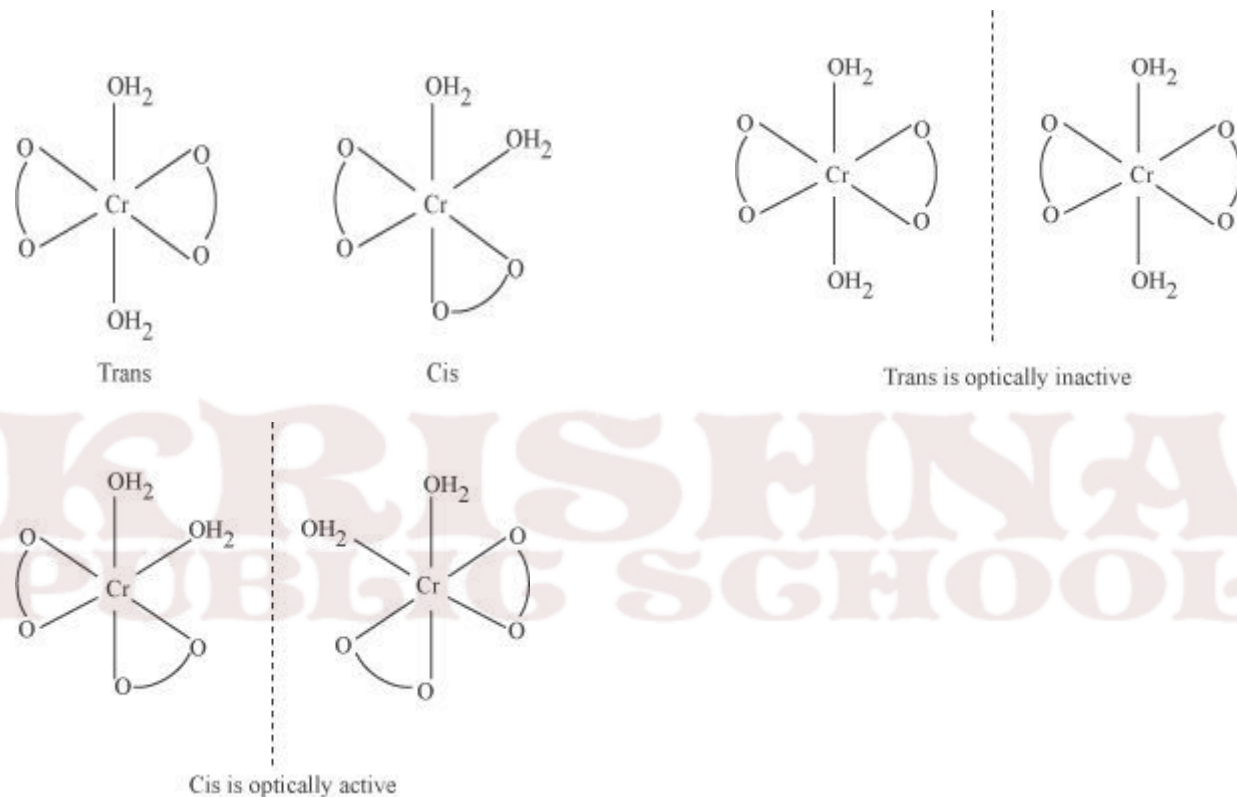

$$\text{Magnetic moment, } \mu = \sqrt{n(n+2)}$$

$$= \sqrt{3(3+2)}$$

$$= \sqrt{15}$$

~ 4BM

(ii) $[Co(NH_3)_5Cl]Cl_2$

IUPAC name: Pentaamminechloridocobalt(III) chloride

Oxidation state of Co = +3

Coordination number = 6

Shape: octahedral.

Electronic configuration: $d^6: t_{2g}^6$.

Stereochemistry:

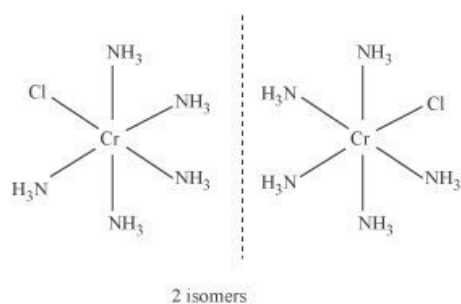

Magnetic Moment = 0

LEVEL 1

1. Why do tetrahedral complex not show geometrical isomerism?
2. Why does the colour changes on heating $[\text{Ti}(\text{H}_2\text{O})_6]^{3+}$.
3. $[\text{Fe}(\text{H}_2\text{O})_6]^{3+}$ is strongly paramagnetic whereas $[\text{Fe}(\text{CN})_6]^{3-}$ is weakly paramagnetic. Explain.
4. What happens when potassium ferrocyanide solution is added to a ferric salt solution?

LEVEL 2

5. A coordination compound has a formula $(\text{CoCl}_3 \cdot 4\text{NH}_3)$. It does not liberate NH_3 but precipitates chloride ion as AgCl . Give the IUPAC name of the complex and write its structural formula.
6. Write the correct formula for the following co-ordination compounds. $\text{CrCl}_3 \cdot 6\text{H}_2\text{O}$ (Violet, with 3 Chloride ions/ Unit formula) $\text{CrCl}_3 \cdot 6\text{H}_2\text{O}$
(Light green colour with 2 Chloride ions/ unit formula)
7. Give the electronic configuration of the d-orbitals of Ti in $[\text{Ti}(\text{H}_2\text{O})_6]^{3+}$ ion in an octahedral crystal field.
8. $\text{Co}(\text{II})$ is stable in aqueous solution but in the presence of strong ligands and air, it can get oxidized to $\text{Co}(\text{III})$. (Atomic Number of cobalt is 27). Explain.
9. Give a chemical test to distinguish between $[\text{Co}(\text{NH}_3)_5\text{Br}]\text{SO}_4$ and $[\text{Co}(\text{NH}_3)_5\text{Br}]\text{SO}_4\text{Br}$. Name the type of isomerism exhibited by these compounds.
10. What is the coordination entity formed when excess of aqueous KCN is added to an aqueous solution of copper sulphate? Why is that no precipitate of copper sulphate is obtained when H_2S (g) is passed through this solution?

LEVEL 3

11. Aqueous copper sulphate solution (blue in colour) gives a green precipitate with aqueous potassium fluoride, a bright green solution with aqueous potassium chloride. Explain these experimental results.

12. A metal complex having the composition $\text{Cr}(\text{NH}_4)_4\text{Cl}_2\text{Br}$ has been isolated in two forms, A and B. The form A reacts with AgNO_3 solution to give a white precipitate readily soluble in dilute aqueous ammonia whereas B give a pale yellow precipitate soluble in concentrated ammonia solution. Write the formulae of A and B and write their IUPAC names.

13. Explain the following

i. All octahedral complexes of Ni^{2+} must be outer orbital complexes. ii.

NH_4^+ ion does not form any complex.

iii. $(\text{SCN})^{-1}$ ion is involved in linkage isomerism in co-ordination compounds.

14. A metal ion Mn^{+} having d^4 valence electronic configuration combines with three didentate ligands to form complexes. Assuming $\Delta_o > P$ Draw the diagram showing d orbital splitting during this complex formation. Write the electronic configuration of the valence electrons of the metal Mn^{+} ion in terms of t_{2g} and e_g . What type of the hybridization will Mn^{+} ion have? Name the type of isomerism exhibited by this complex.

15. The coordination no. of Ni^{2+} is 4.

$\text{NiCl}_2 + \text{KCN}(\text{excess}) \rightarrow \text{A}(\text{a cyano complex})$

$\text{A} + \text{Conc HCl}(\text{excess}) \rightarrow \text{B}(\text{a chloro complex})$

i) Write IUPAC name of A and B

ii) Predict the magnetic nature of A and B

iii) Write hybridization of Ni in A and B

16. Explain the following

i. $\text{Cu}(\text{OH})_2$ is soluble in ammonium hydroxide but not in sodium hydroxide solution. ii.

EDTA is used to cure lead poisoning

iii. Blue coloured solution of $[\text{CoCl}_4]^{2-}$ changes to pink on reaction with HgCl_2 .

1 MARK QUESTIONS

Q1. Write the formula for the following coordination compound:

Tetraammineaquachloridocobalt(III) chloride

Q2. Write the IUPAC name of the following coordination compound:



- Q3. Why is geometrical isomerism not possible in tetrahedral complexes having two different types of unidentate ligands coordinated with the central metal ion ?
- Q4. Out of the following two coordination entities which is chiral (optically active)?
(a) *cis*- $[\text{CrCl}_2(\text{ox})_2]^{3-}$ (b) *trans*- $[\text{CrCl}_2(\text{ox})_2]^{3-}$
- Q5. The spin only magnetic moment of $[\text{MnBr}_4]^{2-}$ is 5.9 BM. Predict the geometry of the complex ion?
- Q6. $[\text{NiCl}_4]^{2-}$ is paramagnetic while $[\text{Ni}(\text{CO})_4]$ is diamagnetic though both are tetrahedral. Why?

2 MARKS QUESTIONS

- Q1. Draw structures of geometrical isomers of $[\text{Fe}(\text{NH}_3)_2(\text{CN})_4]^-$
- Q2. Indicate the type of isomerism exhibited by the following complex and draw the structures for these isomers:
 $[\text{Co}(\text{en})_3]\text{Cl}_3$
- Q3. Give evidence that $[\text{Co}(\text{NH}_3)_5\text{Cl}]\text{SO}_4$ and $[\text{Co}(\text{NH}_3)_5\text{SO}_4]\text{Cl}$ are ionization isomers.
- Q4. Calculate the overall complex dissociation equilibrium constant for the $[\text{Cu}(\text{NH}_3)_4]^{2+}$ ion, given that β_4 for this complex is 2.1×10^{13} .
- Q5. What is meant by unidentate ligand? Give two examples.
- Q6. What is meant by didentate ligand? Give two examples.
- Q7. What is meant by ambidentate ligands? Give two examples.
- Q8. Draw the structures of optical isomers of:
 $[\text{Cr}(\text{C}_2\text{O}_4)_3]^{3-}$
- Q9. Discuss the nature of bonding in metal carbonyls.
- Q10. What is meant by the *chelate effect*? Give an example.
- Q11. Draw the structures of:
(i) $\text{Ni}(\text{CO})_4$ (ii) $\text{Fe}(\text{CO})_5$

3 MARKS QUESTIONS

- Q1. Discuss the nature of bonding in the following coordination entities on the basis of valence bond theory:
(i) $[\text{Fe}(\text{CN})_6]^{4-}$ (ii) $[\text{FeF}_6]^{3-}$ (iii) $[\text{Co}(\text{C}_2\text{O}_4)_3]^{3-}$
Also predict their magnetic behaviour.
- Q2. What is crystal field splitting energy? Draw figure to show the splitting of *d* orbitals in an octahedral crystal field. How does the magnitude of Δ_o decide the actual configuration of *d* orbitals in a coordination entity?
- Q3. Discuss briefly giving an example in each case the role of coordination compounds in:
(i) biological systems (iii) analytical chemistry

(ii) medicinal chemistry .

**KRISHNA
PUBLIC SCHOOL**

UNIT 13: AMINES

2.	Amines	1. Ammonolysis of alkylhalides, Gabriel
		Phthalimide synthesis, Hoffmann Bromamide Degradation. 2. Basic character of Amines(pK_b) and comparisons in gaseous and aqueous phase. 3. Carbylamine Reaction ,Hinsberg's Test. 4. Electrophilic substitution. 5. Diazonium salts –reactions

IUPAC NOMENCLATURE

**KRISHNA
PUBLIC SCHOOL**

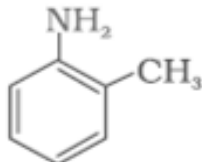
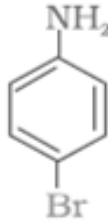
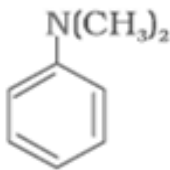
Amine	IUPAC name
$\text{CH}_3\text{-CH}_2\text{-NH}_2$	Ethanamine
$\text{CH}_3\text{-CH}_2\text{-CH}_2\text{-NH}_2$	Propan-1-amine
$\begin{array}{c} \text{CH}_3\text{-CH-CH}_3 \\ \\ \text{NH}_2 \end{array}$	Propan-2-amine
$\begin{array}{c} \text{CH}_3\text{-N-CH}_2\text{-CH}_3 \\ \\ \text{H} \end{array}$	N-Methylethanamine
$\begin{array}{c} \text{CH}_3\text{-N-CH}_3 \\ \\ \text{CH}_3 \end{array}$	N,N-Dimethylmethanamine
$\begin{array}{c} \text{C}_2\text{H}_5\text{-N-CH}_2\text{-CH}_2\text{-CH}_2\text{-CH}_3 \\ \\ \text{C}_2\text{H}_5 \end{array}$	N,N-Diethylbutan-1-amine
$\text{NH}_2\text{-CH}_2\text{-CH}=\text{CH}_2$	Prop-2-en-1-amine
$\text{NH}_2\text{-(CH}_2\text{)}_6\text{-NH}_2$	Hexane-1,6-diamine
	Aniline or Benzenamine
	2-Aminotoluene
	4-Bromobenzenamine or 4-Bromoaniline
	N,N-Dimethylbenzenamine

NAME REACTIONS

1. Gabriel phthalimide synthesis

Gabriel synthesis is used for the preparation of primary amines. Phthalimide on treatment with ethanolic potassium hydroxide forms potassium salt of phthalimide which on heating with alkyl halide followed by alkaline hydrolysis produces the corresponding primary amine. Aromatic primary amines cannot be prepared by this method because aryl halides do not undergo nucleophilic substitution with the anion formed by phthalimide.

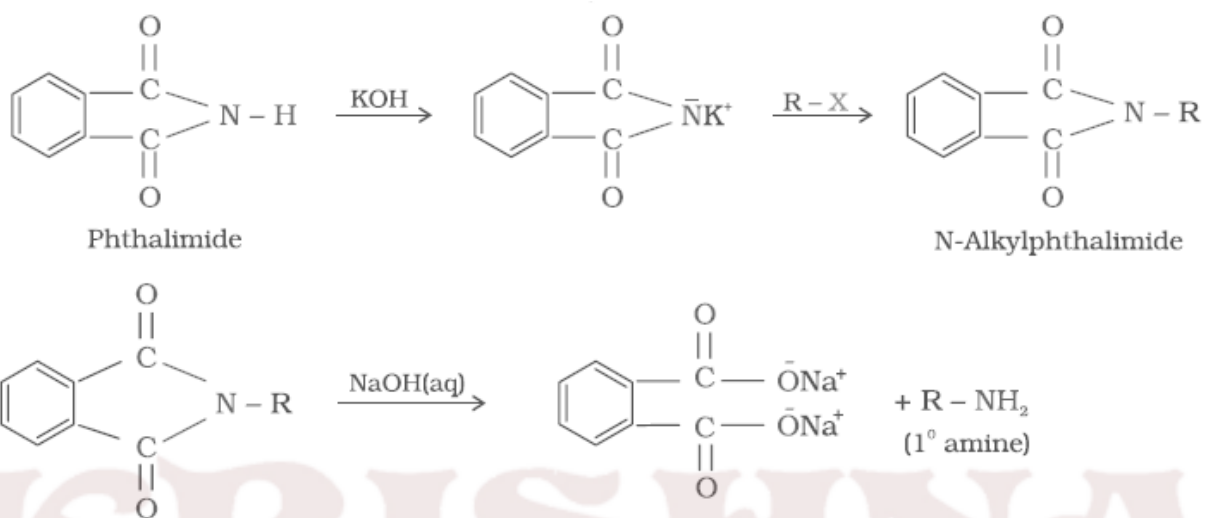

2. Hoffmann bromamide degradation reaction

Hoffmann developed a method for preparation of primary amines by treating an amide with bromine in an aqueous or ethanolic solution of sodium hydroxide. The amine so formed contains one carbon less than that present in the amide.

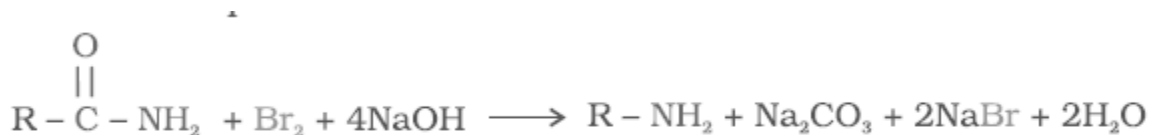

3. Carbylamine reaction

Aliphatic and aromatic primary amines on heating with chloroform and ethanolic potassium hydroxide form isocyanides or carbylamines which are foul smelling substances. Secondary and tertiary amines do not show this reaction. This reaction is known as carbylamine reaction or isocyanide test and is used as a test for primary amines.



4. Hinsberg Test:

Benzenesulphonyl chloride ($C_6H_5SO_2Cl$), which is also known as Hinsberg's reagent, reacts with primary and secondary amines to form sulphonamides.

(a) The reaction of benzenesulphonyl chloride with primary amine yields N-ethylbenzenesulphonyl amide.

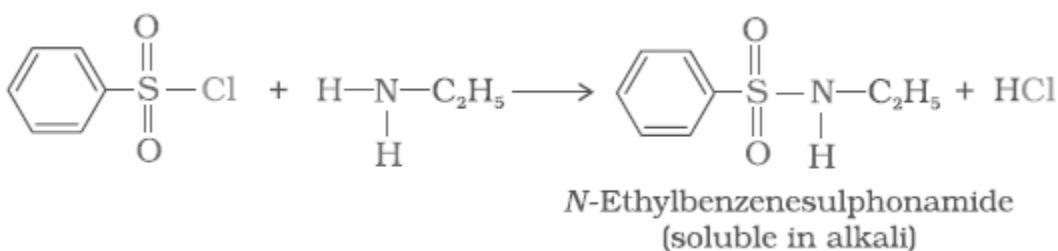

The hydrogen attached to nitrogen in sulphonamide is strongly acidic due to the presence of strong electron withdrawing sulphonyl group. Hence, it is soluble in alkali.

(b) In the reaction with secondary amine, *N,N*-diethylbenzenesulphonamide is formed.

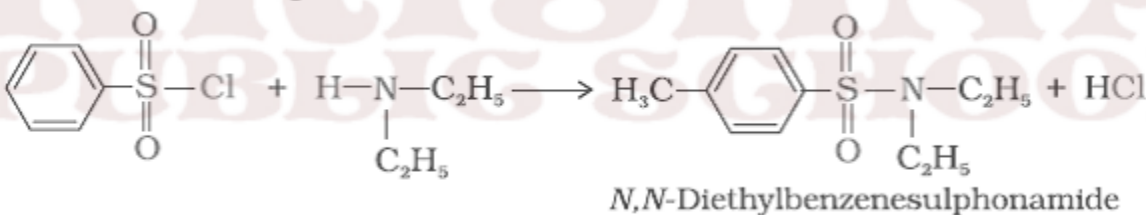

Since *N,N*-diethylbenzene sulphonamide does not contain any hydrogen atom attached to nitrogen atom, it is not acidic and hence insoluble in alkali.

(c) Tertiary amines do not react with benzenesulphonyl chloride. This property of amines reacting with benzenesulphonyl chloride in a different manner is used for the distinction of primary, secondary and tertiary amines and also for the separation of a mixture of amines.

5. Sandmeyer Reaction

The Cl^- , Br^- and CN^- nucleophiles can easily be introduced in the benzene ring of diazonium salts in the presence of $Cu(I)$ ion.

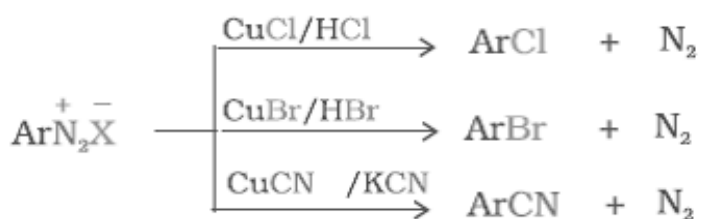

6. Gatterman Reaction

Chlorine or bromine can be introduced in the benzene ring by treating the diazonium salt solution with corresponding halogen acid in the presence of copper powder.

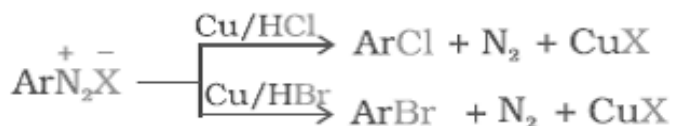

7. Coupling reactions

The azo products obtained have an extended conjugate system having both the aromatic rings joined through the -N=N- bond. These compounds are often coloured and are used as dyes. Benzene diazonium chloride reacts with phenol in which the phenol molecule at its para position is coupled with the diazonium salt to form p-hydroxyazobenzene. This type of reaction is known as coupling reaction.

Similarly the reaction of diazonium salt with aniline yields p-aminoazobenzene.

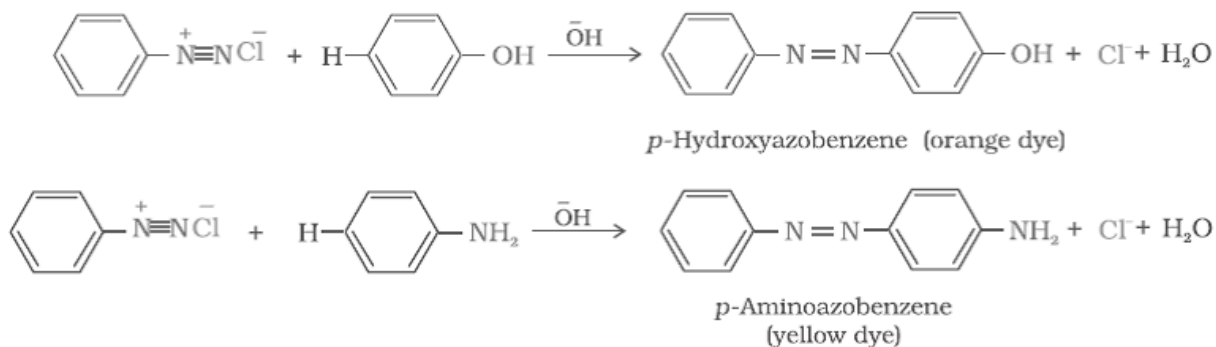

DISTINCTION BETWEEN PAIRS OF COMPOUNDS

Give one chemical test to distinguish between the following pairs of compounds.

- (i) Methylamine and dimethylamine
- (ii) Secondary and tertiary amines
- (iii) Ethylamine and aniline

- (iv) Aniline and benzylamine
 (v) Aniline and N-methylaniline.

ANS. (i) Methylamine and dimethylamine can be distinguished by the carbylamine test. Carbylamine test: Aliphatic and aromatic primary amines on heating with chloroform and ethanolic potassium hydroxide form foul-smelling isocyanides or carbylamines. Methylamine (being an aliphatic primary amine) gives a positive carbylamine test, but dimethylamine does not.

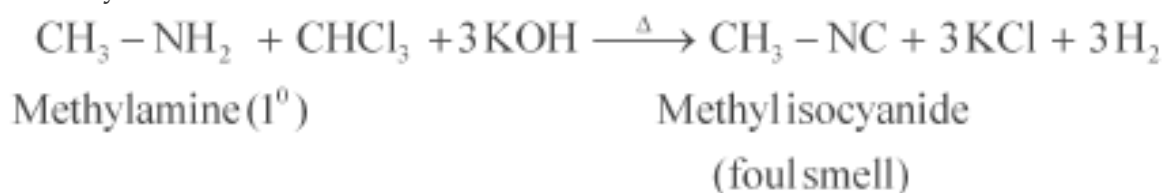

(ii) Secondary and tertiary amines can be distinguished by allowing them to react with Hinsberg's reagent (benzenesulphonyl chloride, $\text{C}_6\text{H}_5\text{SO}_2\text{Cl}$). Secondary amines react with Hinsberg's reagent to form a product that is insoluble in an alkali. For example, N, N-diethylamine reacts with Hinsberg's reagent to form N, N-diethylbenzenesulphonamide, which is insoluble in an alkali. Tertiary amines, however, do not react with Hinsberg's reagent.

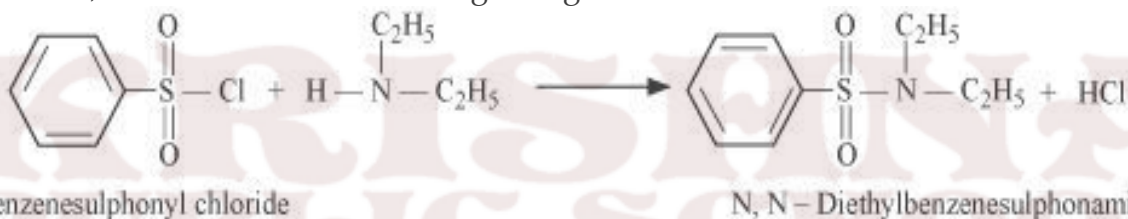

(iii) Ethylamine and aniline can be distinguished using the azo-dye test. A dye is obtained when aromatic amines react with HNO_2 ($\text{NaNO}_2 + \text{dil.HCl}$) at $0-5^\circ\text{C}$, followed by a reaction with the alkaline solution of 2-naphthol. The dye is usually yellow, red, or orange in colour. Aliphatic amines give a brisk effervescence due (to the evolution of N_2 gas) under similar conditions.

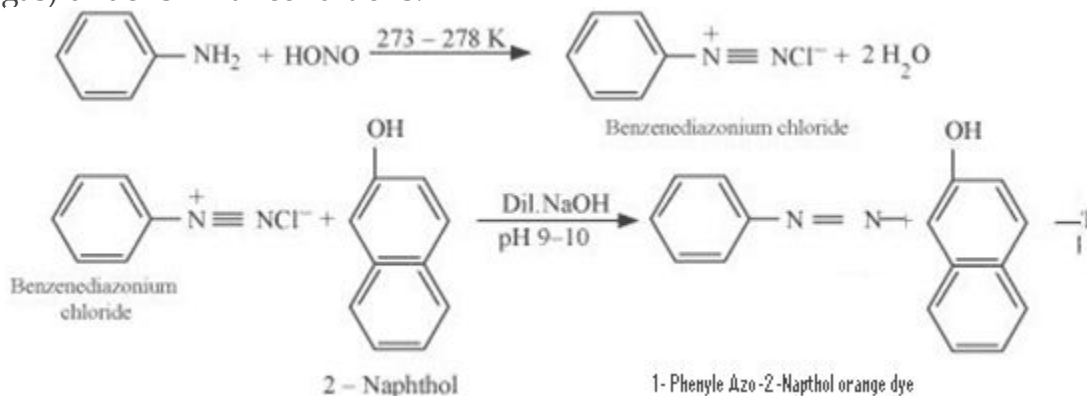

(iv) Aniline and benzylamine can be distinguished by their reactions with the help of nitrous acid, which is prepared in situ from a mineral acid and sodium nitrite.

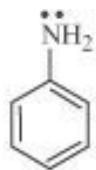

Aniline

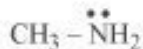

Methylamine

Aniline undergoes resonance and as a result, the electrons on the N-atom are delocalized over the benzene ring. Therefore, the electrons on the N-atom are less available to donate.

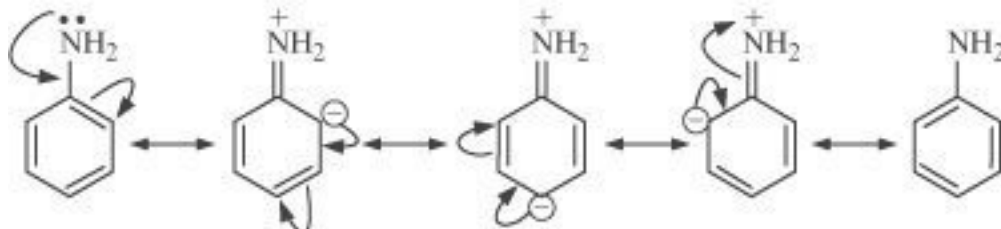

On the other hand, in case of methylamine (due to the +I effect of methyl group), the electron density on the N-atom is increased. As a result, aniline is less basic than methylamine. Thus, pK_b of aniline is more than that of methylamine.

(ii) Ethylamine is soluble in water whereas aniline is not:

Ethylamine when added to water forms intermolecular H-bonds with water. Hence, it is soluble in water.

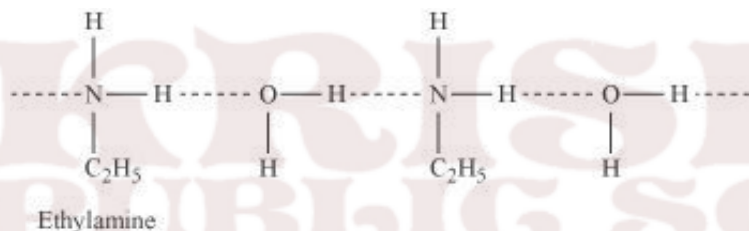

But aniline does not undergo H-bonding with water to a very large extent due to the presence of a large hydrophobic $-\text{C}_6\text{H}_5$ group. Hence, aniline is insoluble in water.

(iii) Methylamine in water reacts with ferric chloride to precipitate hydrated ferric oxide:

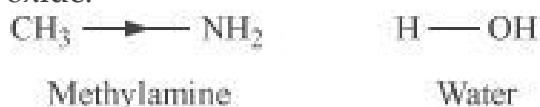

Due to the +I effect of $-\text{CH}_3$ group, methylamine is more basic than water. Therefore, in water, methylamine produces OH^- ions by accepting H^+ ions from water.



Ferric chloride (FeCl_3) dissociates in water to form Fe^{3+} and Cl^- ions.

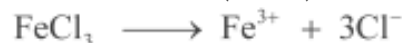

Then, OH^- ion reacts with Fe^{3+} ion to form a precipitate of hydrated ferric oxide.

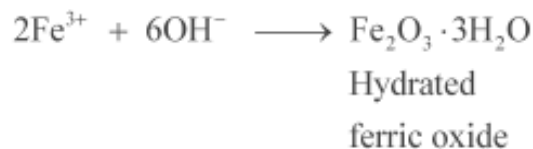

(iv) Although amino group is o,p- directing in aromatic electrophilic substitution reactions, aniline on nitration gives a substantial amount of m-nitroaniline:

Nitration is carried out in an acidic medium. In an acidic medium, aniline is protonated to give anilinium ion (which is meta-directing).



For this reason, aniline on nitration gives a substantial amount of *m*-nitroaniline.

(v) Aniline does not undergo Friedel-Crafts reaction:

A Friedel-Crafts reaction is carried out in the presence of AlCl_3 . But AlCl_3 is acidic in nature, while aniline is a strong base. Thus, aniline reacts with AlCl_3 to form a salt (as shown in the following equation).

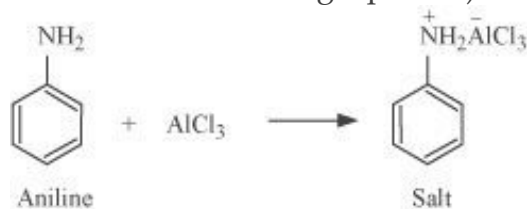

Due to the positive charge on the N-atom, electrophilic substitution in the benzene ring is deactivated. Hence, aniline does not undergo the Friedel-Crafts reaction.

(vi) Diazonium salts of aromatic amines are more stable than those of aliphatic amines:

The diazonium ion undergoes resonance as shown below:

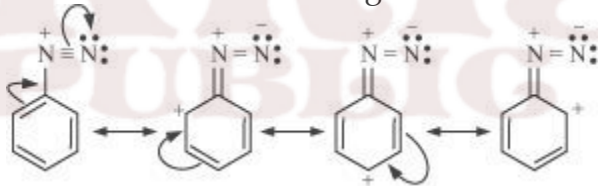

This resonance accounts for the stability of the diazonium ion. Hence, diazonium salts of aromatic amines are more stable than those of aliphatic amines.

(vii) Gabriel phthalimide synthesis is preferred for synthesising primary amines:

Gabriel phthalimide synthesis results in the formation of 1° amine only. 2° or 3° amines are not formed in this synthesis. Thus, a pure 1° amine can be obtained. Therefore, Gabriel phthalimide synthesis is preferred for synthesizing primary amines.

Q2. Why cannot aromatic primary amines be prepared by Gabriel phthalimide

synthesis?

ANS. Gabriel phthalimide synthesis is used for the preparation of aliphatic primary amines. It involves nucleophilic substitution ($\text{S}_{\text{N}}2$) of alkyl halides by the anion formed by the phthalimide.

But aryl halides do not undergo nucleophilic substitution with the anion formed by the phthalimide.

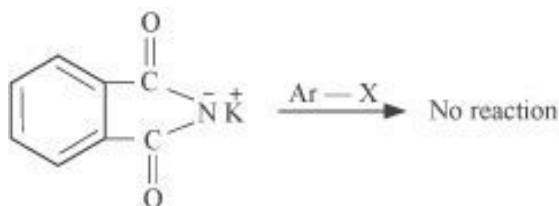

Hence, aromatic primary amines cannot be prepared by this process.

Q3. Give plausible explanation for each of the following:

(i) Why are amines less acidic than alcohols of comparable molecular masses?

(ii) Why do primary amines have higher boiling point than tertiary amines?

(iii) Why are aliphatic amines stronger bases than aromatic amines?

ANS. (i) Amines undergo protonation to give amide ion.

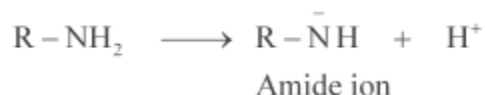

Similarly, alcohol loses a proton to give alkoxide ion.

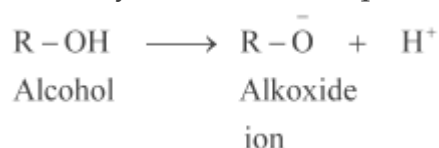

In an amide ion, the negative charge is on the N-atom whereas in alkoxide ion, the negative charge is on the O-atom. Since O is more electronegative than N, O can accommodate the negative charge more easily than N. As a result, the amide ion is less stable than the alkoxide ion. Hence, amines are less acidic than alcohols of comparable molecular masses.

(ii) In a molecule of tertiary amine, there are no H-atoms whereas in primary amines, two hydrogen atoms are present. Due to the presence of H-atoms, primary amines undergo extensive intermolecular H-bonding.

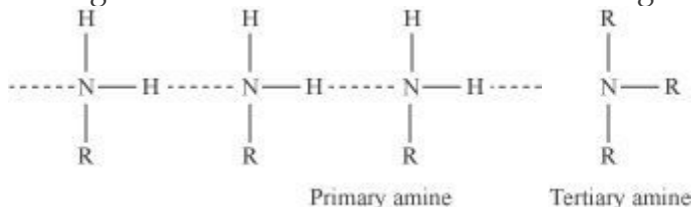

As a result, extra energy is required to separate the molecules of primary amines. Hence, primary amines have higher boiling points than tertiary amines.

(iii) Due to the $-R$ effect of the benzene ring, the electrons on the N-atom are less available in case of aromatic amines. Therefore, the electrons on the N-atom in aromatic amines cannot be donated easily. This explains why aliphatic amines are stronger bases than aromatic amines.

SOLVED QUESTIONS

1 MARK QUESTIONS

Q1. Give the IUPAC name of the compound and classify into primary, secondary or tertiary amines.

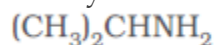

1-Methylethanamine (1° amine)

Q2. Give the IUPAC name of the compound and classify into primary, secondary or tertiary amines.

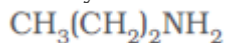

Propan-1-amine (1° amine)

Q3. Give the IUPAC name of the compound and classify into primary, secondary or tertiary amines.



N-Methyl-2-methylethanamine (2° amine)

Q4. Give the IUPAC name of the compound and classify into primary, secondary or tertiary amines.

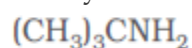

2-Methylpropan-2-amine (1° amine)

Q5. Give the IUPAC name of the compound and classify into primary, secondary or tertiary amines.

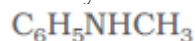

N-Methylbenzamine or N-methylaniline (2° amine)

Q6. Write short notes on diazotization

Aromatic primary amines react with nitrous acid (prepared in situ from NaNO_2 and a mineral acid such as HCl) at low temperatures (273-278 K) to form diazonium salts. This conversion of aromatic primary amines into diazonium salts is known as diazotization. For example, on treatment with NaNO_2 and HCl at 273–278 K, aniline produces benzenediazonium chloride, with NaCl and H_2O as by-products.



Q7. Write short notes on ammonolysis

When an alkyl or benzyl halide is allowed to react with an ethanolic solution of ammonia, it undergoes nucleophilic substitution reaction in which the halogen atom is replaced by an amino ($-\text{NH}_2$) group. This process of cleavage of the carbon-halogen bond is known as ammonolysis.

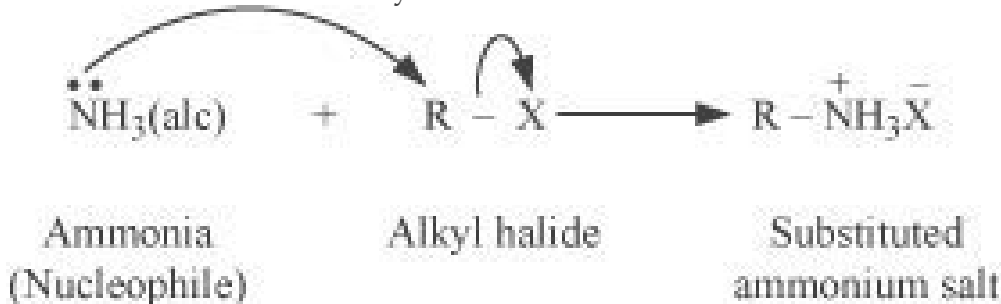

When this substituted ammonium salt is treated with a strong base such as sodium hydroxide, amine is obtained.

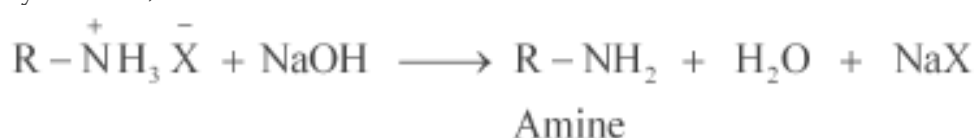

Though primary amine is produced as the major product, this process produces a mixture of primary, secondary and tertiary amines, and also a quaternary ammonium salt

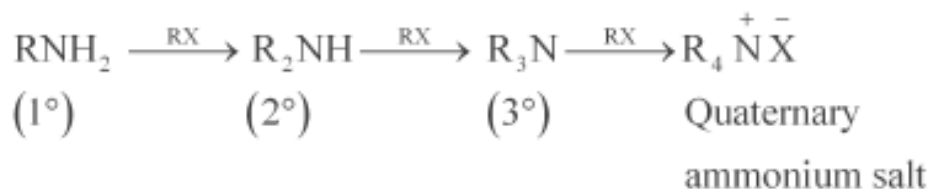

Q8. Write short notes on acetylation.

Acetylation (or ethanoylation) is the process of introducing an acetyl group into a molecule. Aliphatic and aromatic primary and secondary amines undergo acetylation reaction by nucleophilic substitution when treated with acid chlorides, anhydrides or esters. This reaction involves the replacement of the hydrogen atom of $-\text{NH}_2$ or $>\text{NH}$ group by the acetyl group, which in turn leads to the production of amides. To shift the equilibrium to the right hand side, the HCl formed during the reaction is removed as soon as it is formed. This reaction is carried out in the presence of a base (such as pyridine) which is stronger than the amine.

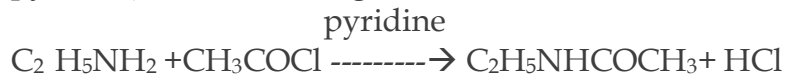

Q9. Why are amines basic in character?

ANS. Like ammonia, the nitrogen atom in amines RNH_2 is trivalent and bears an unshared pair of electrons. Thus it acts like a Lewis base and donates the pair of electrons to electron-deficient species which further increases due to +I effect of alkyl radical.

Q10. Arrange the following in decreasing order of their basic strength:



The decreasing order of basic strength of the above amines and ammonia

follows the following order:

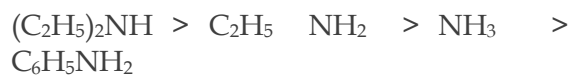

SOLVED EXAMPLES (2 Marks)

Q1. Write chemical equations for the following reactions:

(i) Reaction of ethanolic NH_3 with $\text{C}_2\text{H}_5\text{Cl}$.

(ii) Ammonolysis of benzyl chloride and reaction of amine so formed

with two moles of CH_3Cl

ANS.

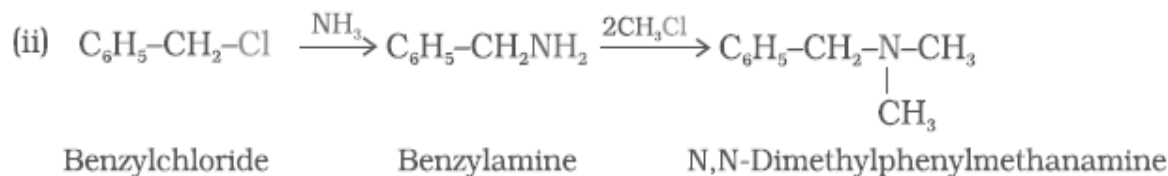
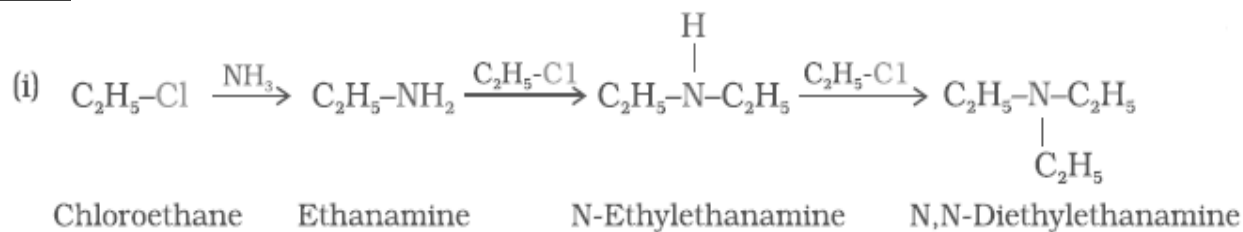

Q2. Write chemical equations for the following conversions:

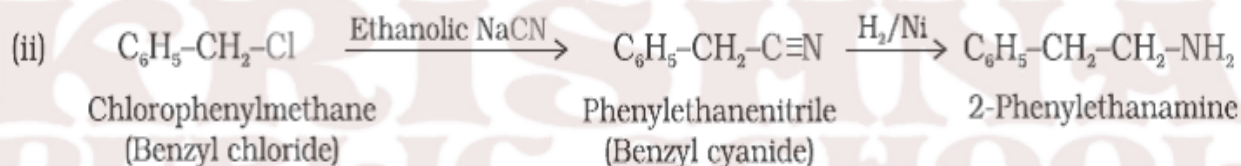
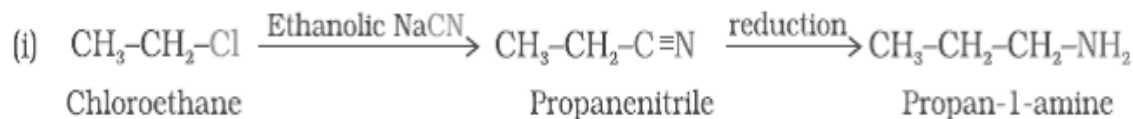

Q3. Write structures and IUPAC names of

(i) the amide which gives propanamine by Hoffmann bromamide reaction.

(ii) the amine produced by the Hoffmann degradation of benzamide.

ANS. (i) Propanamine contains three carbons. Hence, the amide molecule must contain four carbon atoms. Structure and IUPAC name of the starting amide with four carbon atoms are given below:

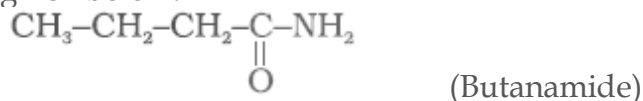

(ii) Benzamide is an aromatic amide containing seven carbon atoms. Hence, the amine formed from benzamide is aromatic primary amine containing six carbon atoms.

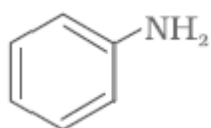

(Aniline or benzenamine)

Q4. How will you convert 4-nitrotoluene to 2-bromobenzoic acid?

ANS.

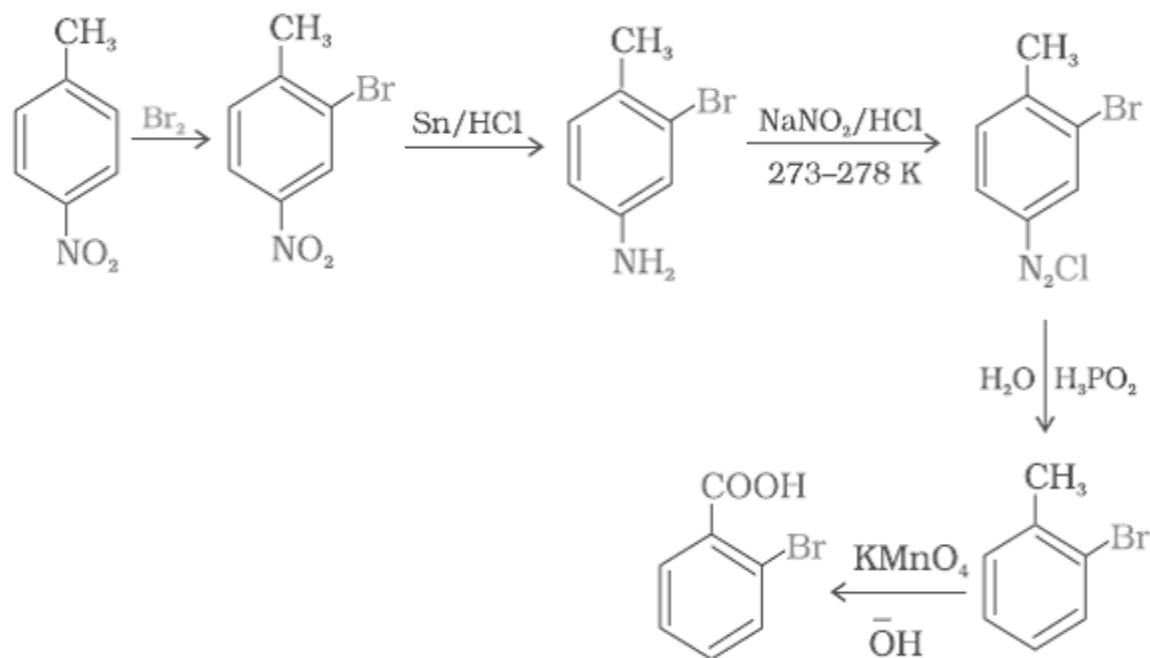

Q5. Write the reactions of (i) aromatic and (ii) aliphatic primary amines with nitrous acid.

ANS. (i) Aromatic amines react with nitrous acid (prepared in situ from NaNO_2 and a mineral acid such as HCl) at $273 - 278 \text{ K}$ to form stable aromatic diazonium salts i.e., NaCl and $2\text{H}_2\text{O}$.

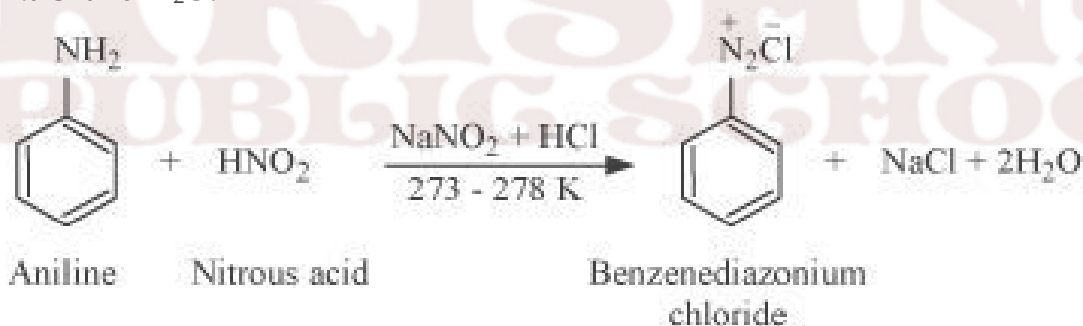

(ii) Aliphatic primary amines react with nitrous acid (prepared in situ from NaNO_2 and a mineral acid such as HCl) to form unstable aliphatic diazonium salts, which further produce alcohol and HCl with the evolution of N_2 gas.

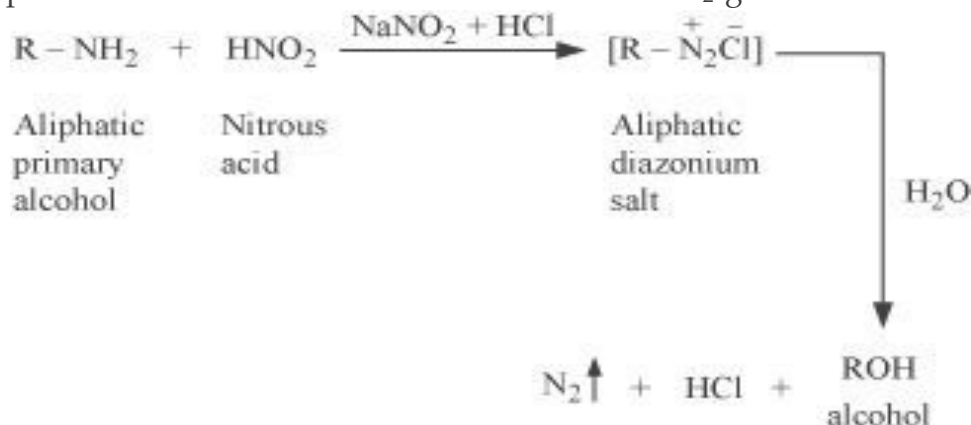

Q6. How will you convert:

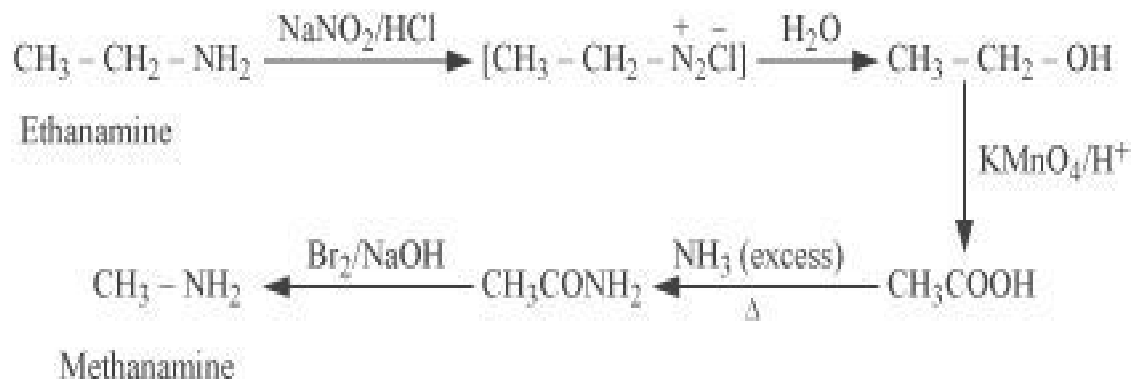

Q8. How will you convert

(i) Ethanoic acid into propanoic acid

(ii) Methanamine into ethanamine

ANS. (i)

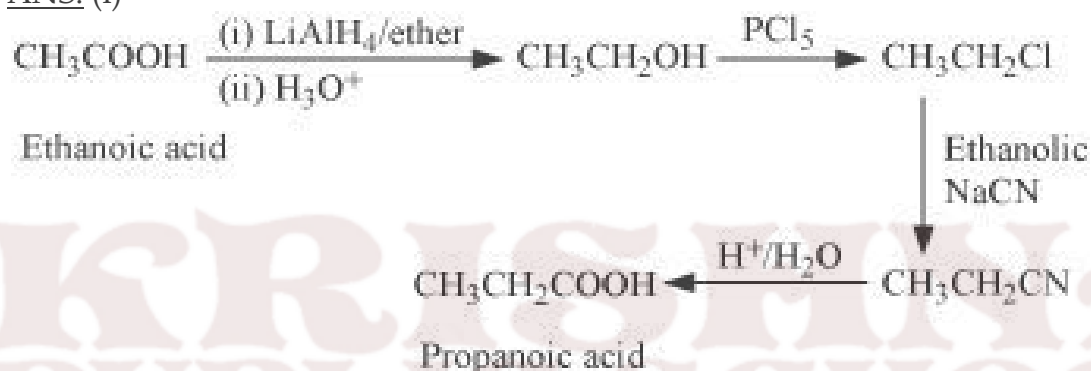

(ii)

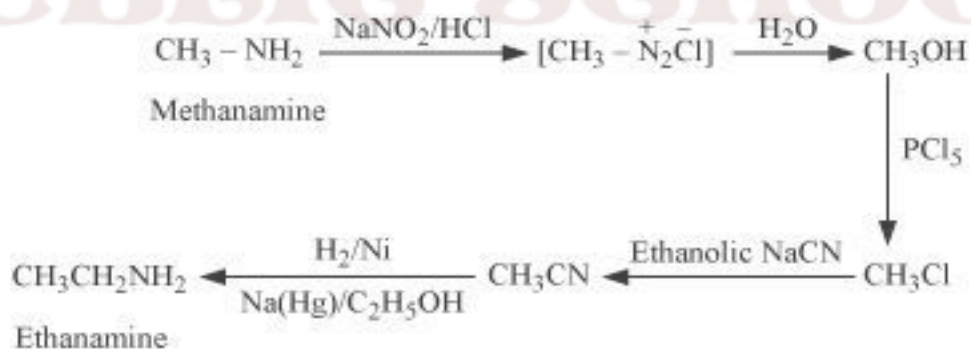

Q9. How will you convert

(i) Nitromethane into dimethylamine

(ii) Propanoic acid into ethanoic acid?

(i)

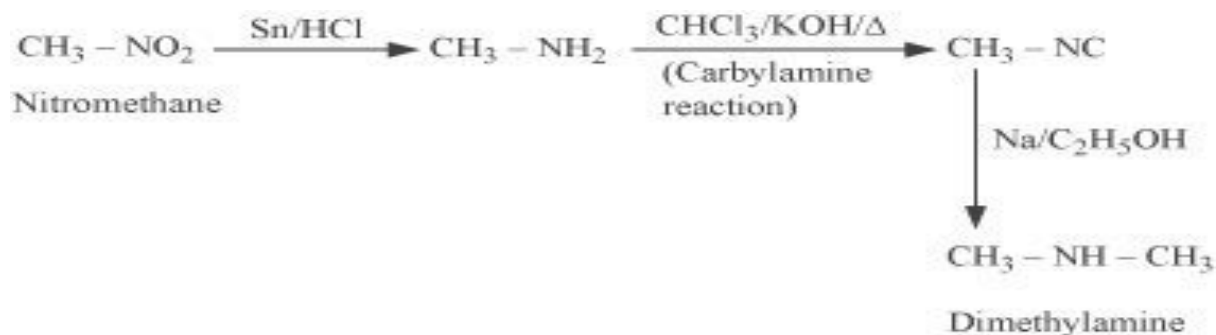

(ii)

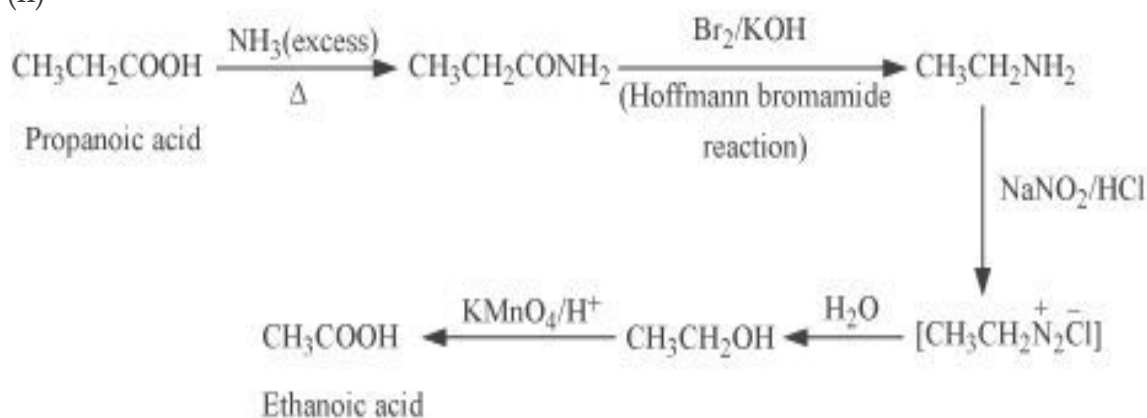

Q10. An aromatic compound 'A' on treatment with aqueous ammonia and heating forms compound 'B' which on heating with Br_2 and KOH forms a compound 'C' of molecular formula $\text{C}_6\text{H}_7\text{N}$. Write the structures and IUPAC names of compounds A, B and C.

ANS. It is given that compound 'C' having the molecular formula, $\text{C}_6\text{H}_7\text{N}$ is formed by heating compound 'B' with Br_2 and KOH . This is a Hoffmann bromamide degradation reaction. Therefore, compound 'B' is an amide and compound 'C' is an amine. The only amine having the molecular formula, $\text{C}_6\text{H}_7\text{N}$ is aniline, ($\text{C}_6\text{H}_5\text{NH}_2$). The given reactions can be explained with the help of the following equations:

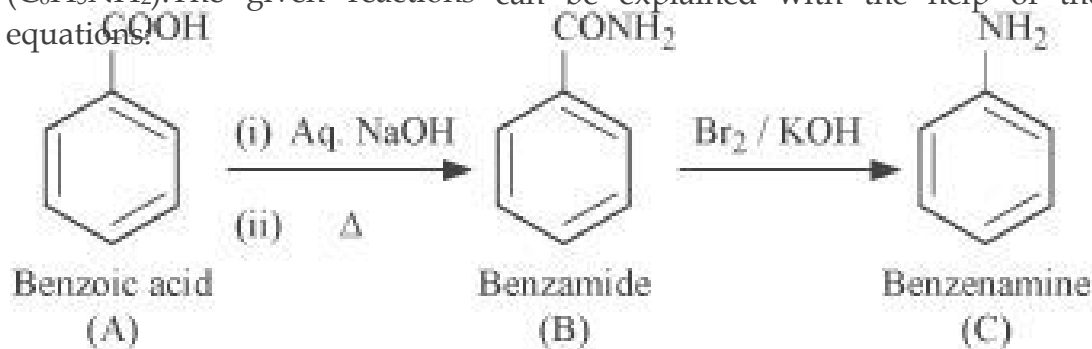

3 MARKS QUESTIONS

Q1. Arrange the following:

- (i) In decreasing order of the pK_b values:
 $\text{C}_2\text{H}_5\text{NH}_2$, $\text{C}_6\text{H}_5\text{NHCH}_3$, $(\text{C}_2\text{H}_5)_2\text{NH}$ and $\text{C}_6\text{H}_5\text{NH}_2$

(ii) In increasing order of basic strength:

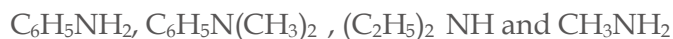

(iii) In increasing order of basic strength:

Aniline, p-nitroaniline and p-toluidine

ANS. (i) The order of increasing basicity of the given compounds is as follows:

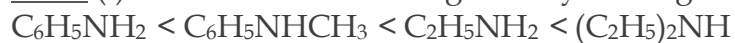

We know that the higher the basic strength, the lower is the pK_b values.

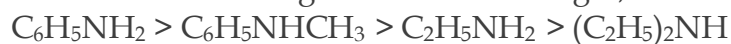

(ii) The increasing order of the basic strengths of the given compounds is as follows:

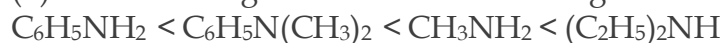

(iii) The increasing order of the basic strengths of the given compounds is :

p-Nitroaniline < Aniline < p-Toluidine

Q2. Arrange the following

(i) In decreasing order of basic strength in gas phase:



(ii) In increasing order of boiling point:

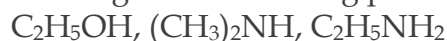

(iii) In increasing order of solubility in water:

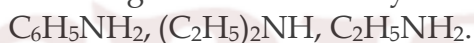

ANS. (i) The given compounds can be arranged in the decreasing order of their basic strengths in the gas phase as follows:



(ii) The given compounds can be arranged in the increasing order of their boiling points as follows:



(iii) The more extensive the H-bonding, the higher is the solubility. $\text{C}_2\text{H}_5\text{NH}_2$ contains two H-atoms whereas $(\text{C}_2\text{H}_5)_2\text{NH}$ contains only one H-atom. Thus, $\text{C}_2\text{H}_5\text{NH}_2$ undergoes more extensive H-bonding than $(\text{C}_2\text{H}_5)_2\text{NH}$. Hence, the solubility in water of $\text{C}_2\text{H}_5\text{NH}_2$ is more than that of $(\text{C}_2\text{H}_5)_2\text{NH}$.

Q3. Accomplish the following conversions:

(i) Nitrobenzene to benzoic acid

(ii) Benzene to m-bromophenol

(iii) Benzoic acid to aniline

ANS. (i)

ANS. (i)

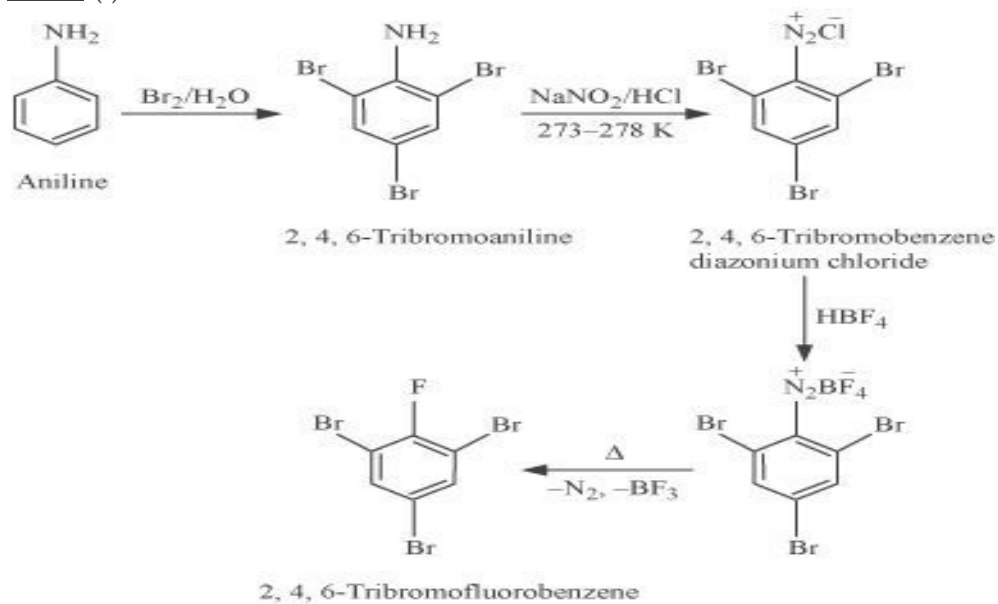

(ii)

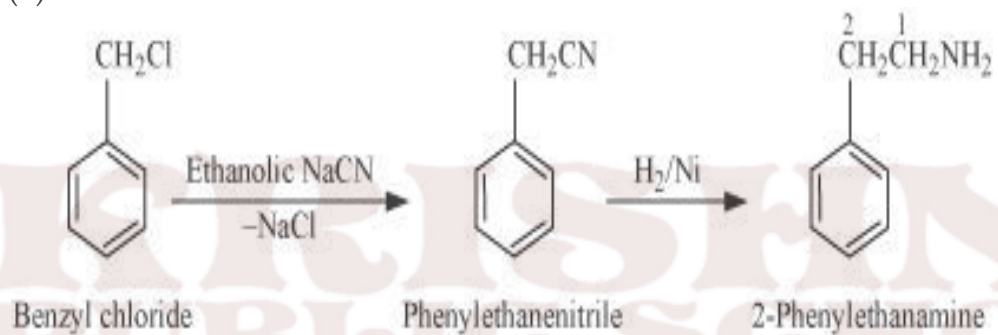

(iii)

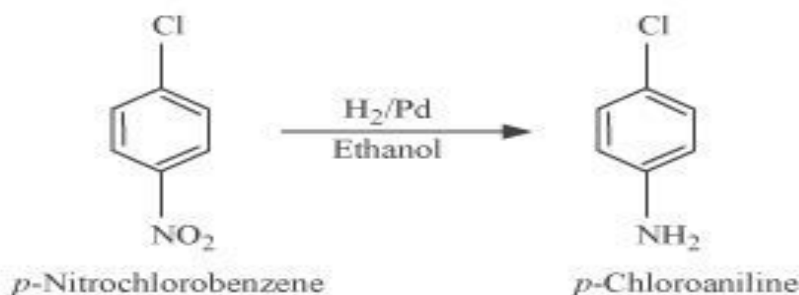

Q5. Accomplish the following conversions:

- (i) Aniline to *p*-bromoaniline
- (ii) Benzamide to toluene
- (iii) Aniline to benzyl alcohol.

ANS. (i)

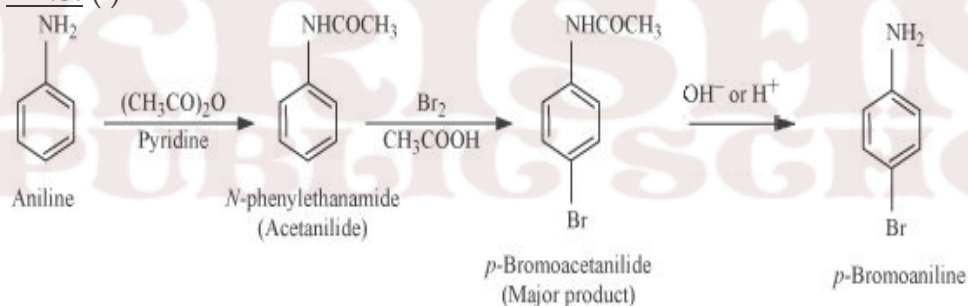

(ii)

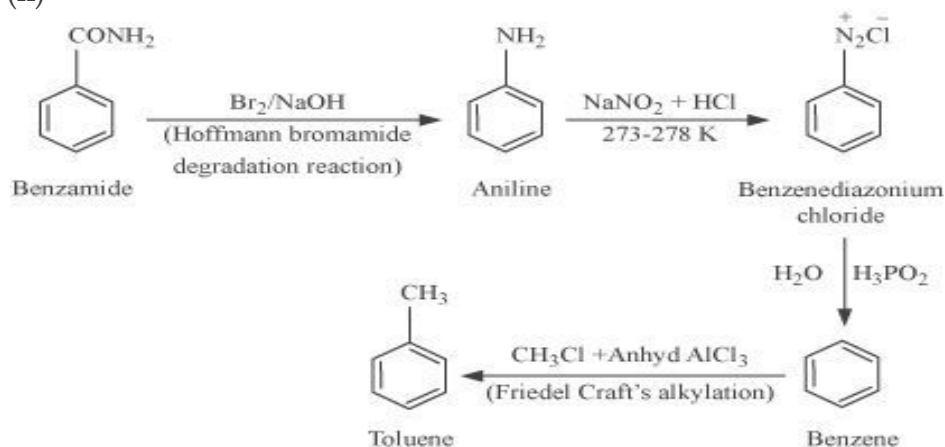

(iii)

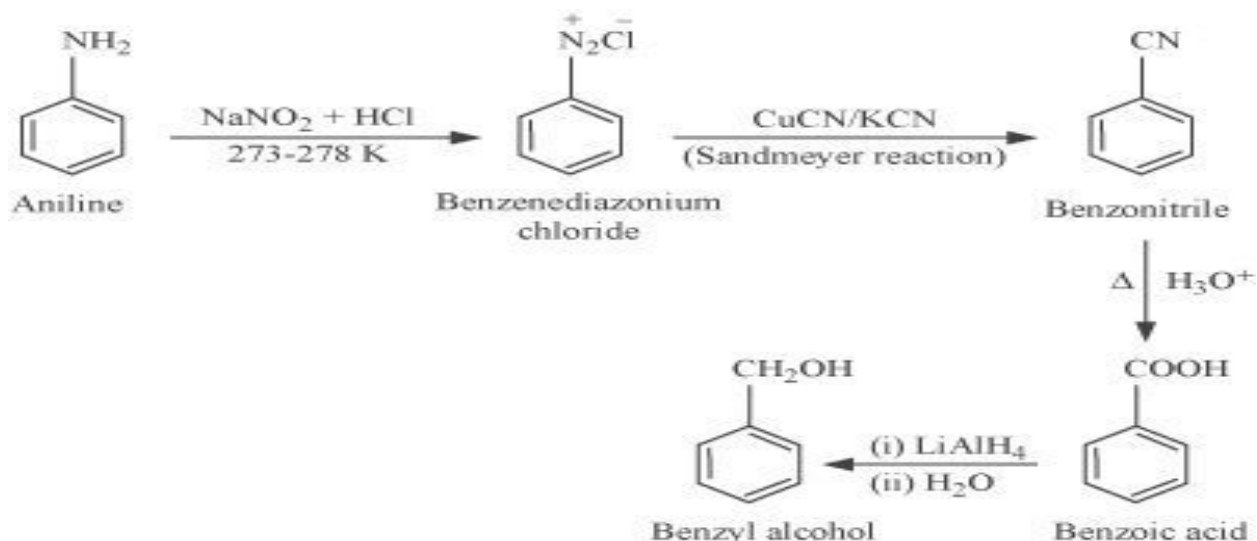

5 MARKS QUESTIONS

Q1. Give the structures of A, B and C in the following reactions:

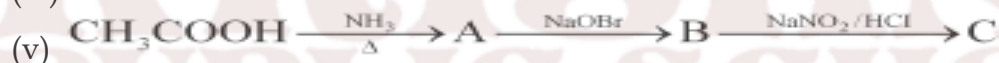

ANS. (i)

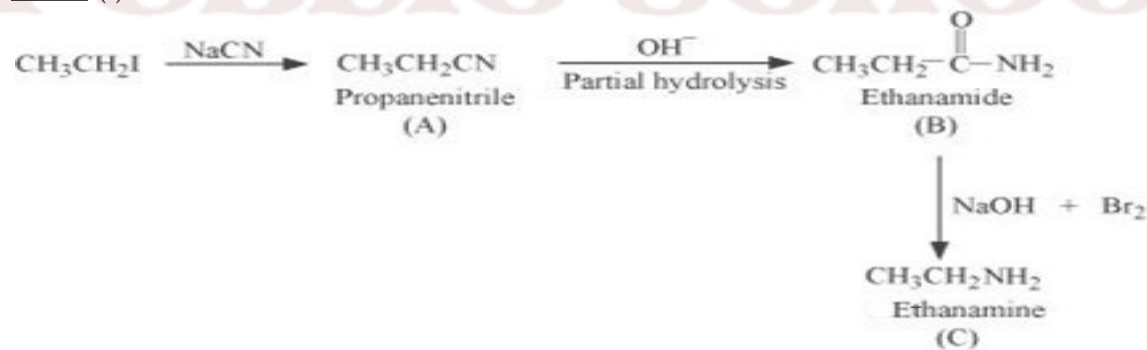

(ii)

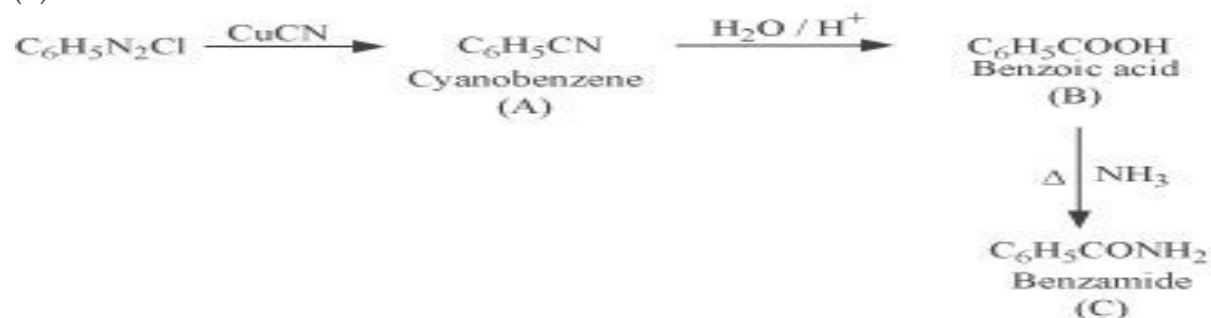

(iii)

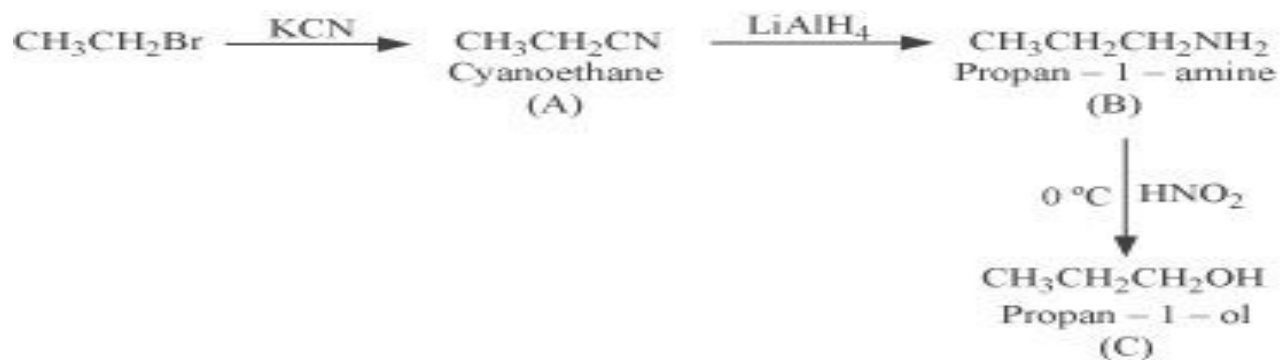

(iv)

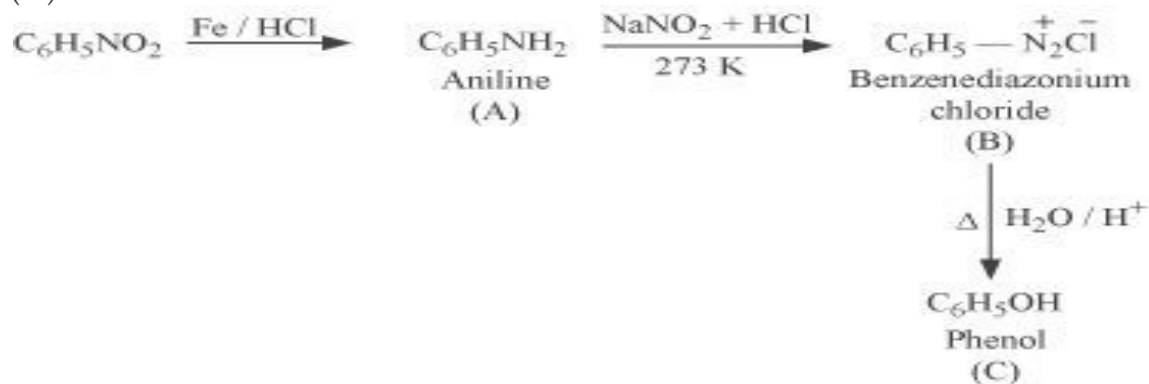

(v)

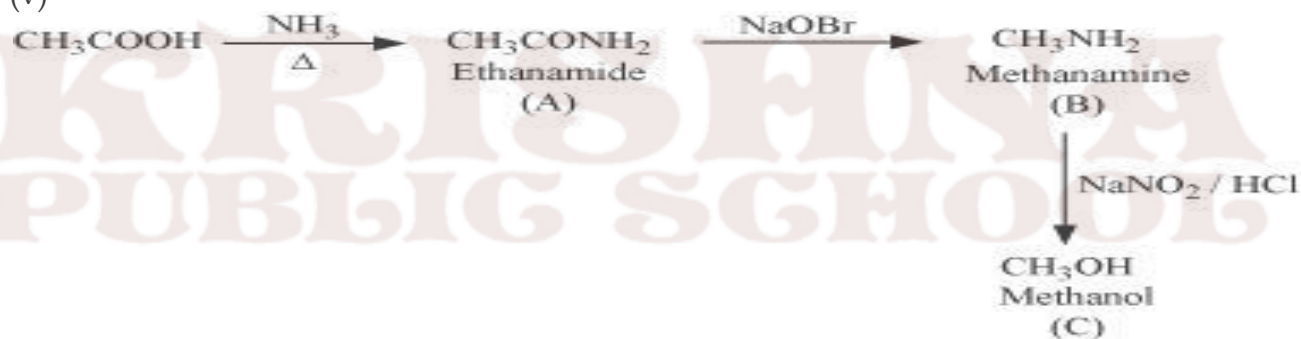

Q2. Complete the following reactions:

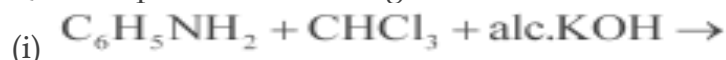

ANS. (i)

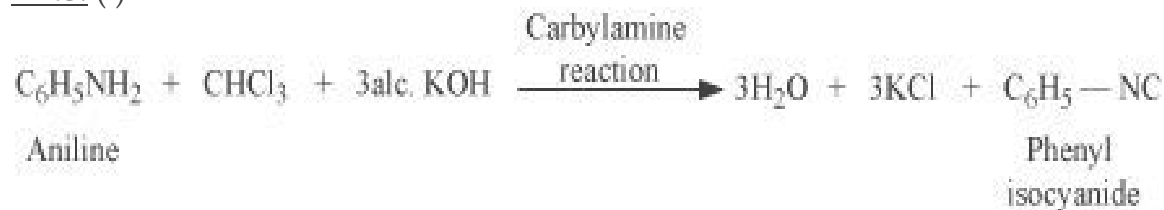

(ii)

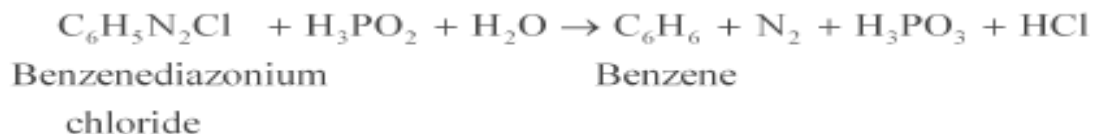

(iii)

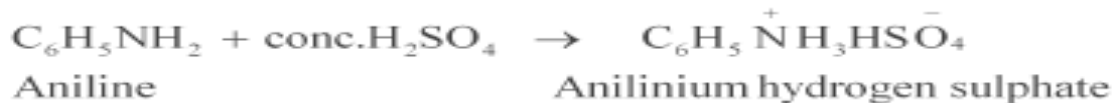

(iv)

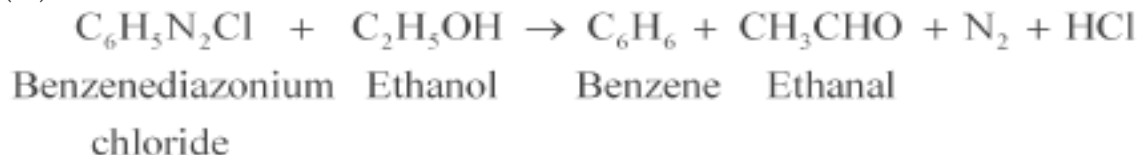

(v)

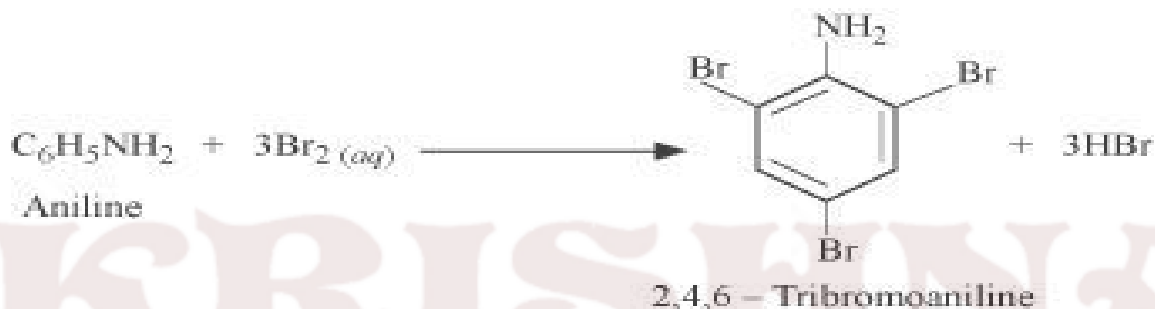

Assignments

Level 1

1. Write IUPAC Name of $\text{C}_6\text{H}_5\text{N}(\text{CH}_3)_3\text{Br}$?
2. Which reaction is used for preparation of pure aliphatic & aralkyl primary amine ?
3. Name one reagent used for the separation of primary, secondary & tertiary amine ?
4. What amine salts are used for determining their molecular masses ?
5. What is the directive influence of amino group in arylamines ?
6. Why are benzene diazonium salts soluble in water ?
7. Which is more basic: CH_3NH_2 & $(\text{CH}_3)_3\text{N}$?
8. Which is more acidic, aniline or ammonia ?
9. Write the IUPAC name of $\text{C}_6\text{H}_5\text{NHCH}_3$?
10. Mention two uses of sulphanilic acid?

Level 2

1. What for are quaternary ammonium salts widely used ?
2. What product is formed when aniline is first diazotized and then treated with Phenol in alkaline medium ?
3. How is phenyl hydrazine prepared from aniline ?
4. What is the IUPAC name of a tertiary amine containing one methyl, one ethyl And one n-propyl group ?
5. Explain why silver chloride is soluble in aqueous solution of methylamine ?
6. Write the IUPAC name of $\text{C}_6\text{H}_5\text{N}(\text{CH}_3)_3\text{Br}$?
7. Primary amines have higher boiling points than tertiary amines why ?

- Why is it necessary to maintain the temperature between 273 K & 278 K during diazotization?
- Arrange the following in order of decreasing basic strength : Ethyl amine, Ammonia, Triethylamine ?
- Why aniline is acetylated first to prepare mono bromo derivative?

LEVEL 3

- Arrange the following in decreasing order of their basic strength.

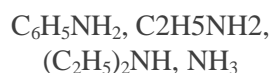

- Write chemical equation for the conversion

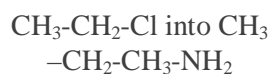

- Write the equation involved in Carbylamines reactions?

- How will you distinguish the following pairs? (i)

Methanamine and N-methyl

methane amine (ii) Aniline and

ethyl amine

- Write chemical sections involved in following name reactions. (i)

Hoffmann Bromoamide reaction. (ii)

Diazotisation reaction.

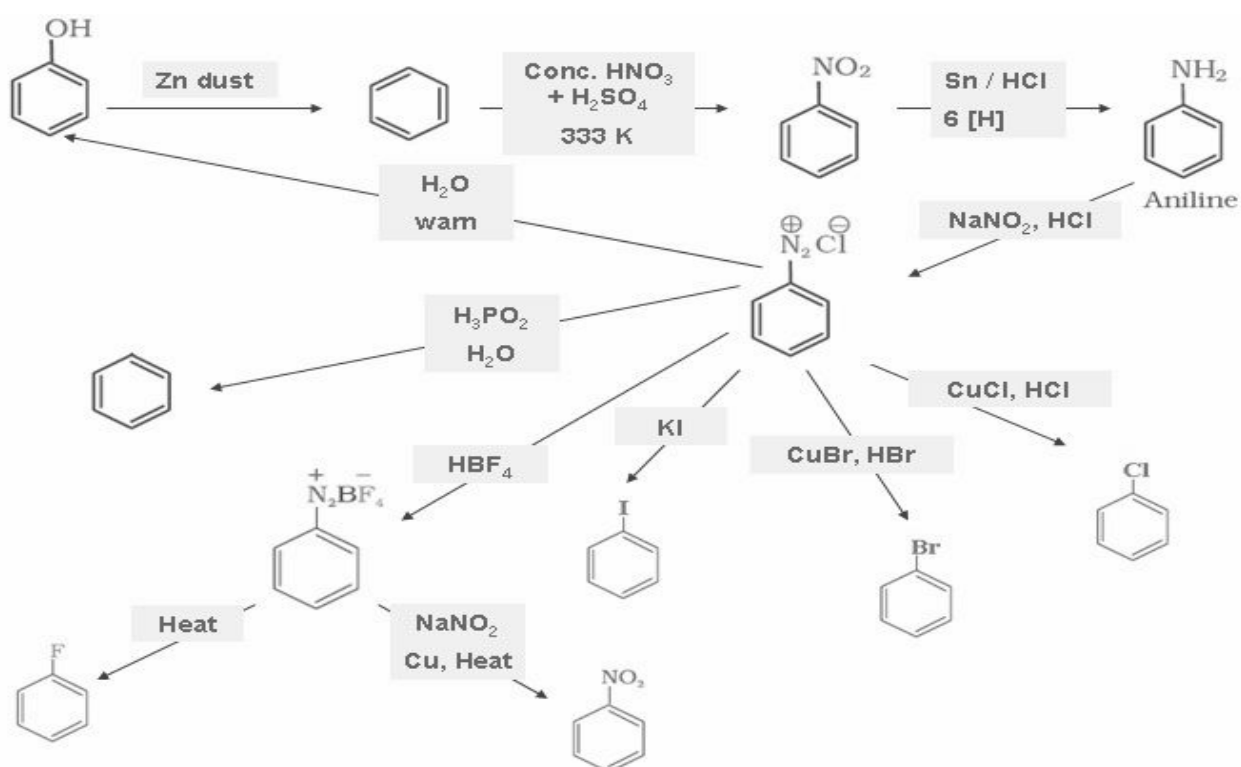

COMMON ERRORS

Basic character of amines in aqueous and in gaseous state, p_{ka} and p_{kb} values

1 MARK QUESTIONS

Q1. Arrange the following in decreasing order of their basic strength:

$C_6H_5NH_2$, $C_2H_5NH_2$, $(C_2H_5)_2NH$, NH_3

Q2. Arrange the following in decreasing order of the pK_b values:

$C_2H_5NH_2$, $C_6H_5NHCH_3$, $(C_2H_5)_2NH$ and $C_6H_5NH_2$

Q3. pK_b of aniline is more than that of methylamine. Why?

Q4. Ethylamine is soluble in water whereas aniline is not. Give reason.

Q5. Methylamine in water reacts with ferric chloride to precipitate hydrated ferric oxide. Why?

Q6. Although amino group is *o*- and *p*- directing in aromatic electrophilic substitution reactions, aniline on nitration gives a substantial amount of *m*-nitroaniline. Give reason.

Q7. Aniline does not undergo Friedel-Crafts reaction. Why?

Q8. Diazonium salts of aromatic amines are more stable than those of aliphatic amines. Why?

Q9. Gabriel phthalimide synthesis is preferred for synthesising primary amines. Give reason

Q10. Why cannot aromatic primary amines be prepared by Gabriel phthalimide synthesis?

Q11. Why do primary amines have higher boiling point than tertiary amines?

Q12. Why are aliphatic amines stronger bases than aromatic amines?

Q13. Direct nitration of aniline is not carried out. Give reason.

Q14. The presence of base is needed in the ammonolysis of alkyl halides. Why?

2 MARKS QUESTIONS

Q1. Write structures and IUPAC names of

(i) the amide which gives propanamine by Hoffmann bromamide reaction.

(ii) the amine produced by the Hoffmann degradation of benzamide.

Q2. Give one chemical test to distinguish between the following pairs of compounds.

(i) Methylamine and dimethylamine (ii) Ethylamine and aniline

Q3. Write short notes on the following:

(i) Carbylamine reaction (ii) Diazotisation

Q4. Explain the following with the help of an example.

(i) Hofmann's bromamide reaction (ii) Coupling reaction

Q5. Explain the following with the help of an example.

(i) Ammonolysis (ii) Gabriel phthalimide synthesis

Q6. How can you convert an amide into an amine having one carbon less than the starting compound? Name the reaction.

Q7. Give a chemical test to distinguish between:

(a) $C_6H_5NH_2$ & CH_3NH_2

(b) CH_3NHCH_3 & $(CH_3)_3N$

Q8. Give the IUPAC names of:

(a) $(CH_3)_2CHNH_2$

(b) $(CH_3CH_2)_2NCH_3$

Q9. Write the structures of:

(a) 3-Bromobenzenamine

(b) 3-Chlorobutanamide

3 MARKS QUESTIONS

Q1. How will you convert

(i) Benzene into aniline (ii) Benzene into N, N-dimethylaniline

(iii) Aniline to Sulphanilic acid

Q2. An aromatic compound 'A' on treatment with aqueous ammonia and heating forms compound 'B' which on heating with Br_2 and KOH forms a compound 'C' of molecular formula C_6H_7N . Write the structures and IUPAC names of compounds A, B and C.

Q3. How will you carry out the following conversions (Write Chemical equations and reaction conditions):

(a) Aniline to Phenol

(b) Acetamide to Ethylamine

(c) Aniline to *p*-nitroaniline

GENERAL ORGANIC CHEMISTRY

(1) When two half filled atomic orbitals to same or different atoms are brought near to each other, they overlap (combine) and form new orbitals called molecular orbitals. The molecular orbitals that are formed encompass both nuclei, and in them, the electrons can move about both nuclei. The electrons are not restricted to the vicinity of one nucleus or the other as they were in the separate atomic orbital

(2) When atomic orbitals combine to form molecular orbitals, the number of molecular orbitals that result always equals the number of atomic orbitals that combine.

Thus in the formation of hydrogen molecule the two atomic orbitals of two hydrogen atoms combine to produce two molecular orbitals. Two molecular orbitals result because the mathematical properties of wave function permit them to be combined by linear combination. Linear combination of atomic orbital may be either addition or subtraction, i.e., they can combine either in phase or out of phase.

(3) When orbitals with like signs (in phase combination or addition) overlap, a bonding molecular orbital results. It has a higher electron density between the two atoms, thus minimizing nuclear repulsion and permitting the nuclei to be closer to each other than in the un bonded state. It has lower energy than the individual separated atomic orbitals. Attraction force (between protons of one atom and electrons of the other atom) would be greater than the repulsive force in this case.

(4) When orbitals with unlike signs (out of the phase overlapping, subtraction) overlap an antibonding molecular orbital results. It has a node (no electron density) in the region between the nuclei. The repulsion of its nuclei is higher and it has a higher energy than the individual separated atomic orbitals. Antibonding molecular orbital contains no electrons in the ground state of the molecule. Repulsive force (between the two nuclei and between the electrons of the two atoms) would be greater than the attraction force.

An energy diagram for the molecular orbital for the hydrogen molecule is shown in fig. given below. Notice that electrons are placed in molecular orbitals in the same way that they were in the atomic orbitals (i.e., molecular orbitals follow Aufbau principle, and Hund's rule). Two electrons (with their opposite spin) occupy the BMO, where their total energy is less than these separate atomic orbitals. This is the lowest electronic state or ground state of the hydrogen molecule.

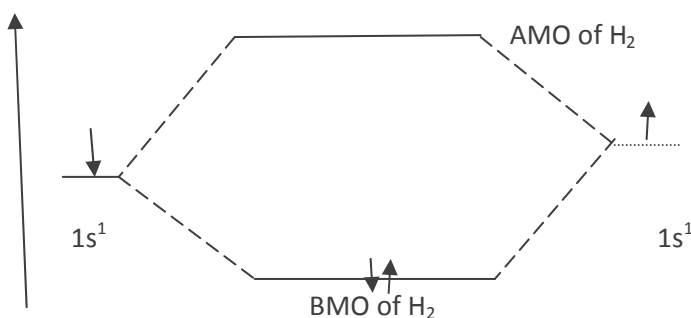

Number of electrons pairs tell us the type of hybridization as follows:

ep	hybridization
2	sp
3	sp ²
4	sp ³
5	sp ³ d
6	sp ³ d ²

Examples:

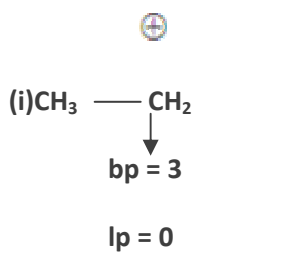

ep = 3, sp²

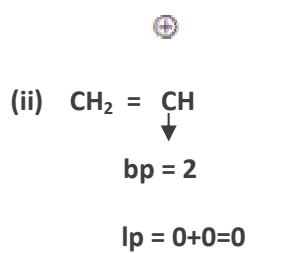

ep = 2, sp

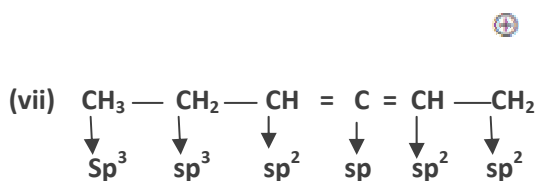
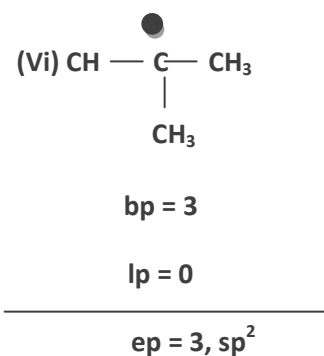
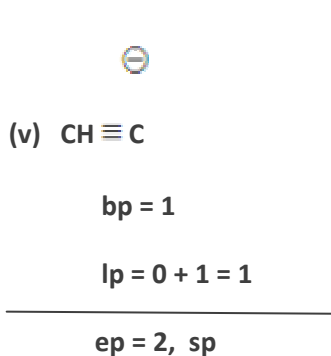
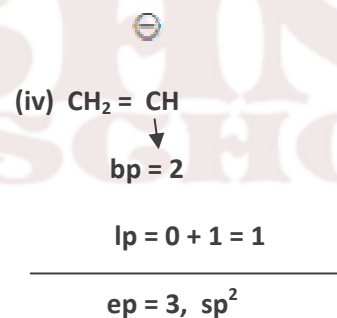
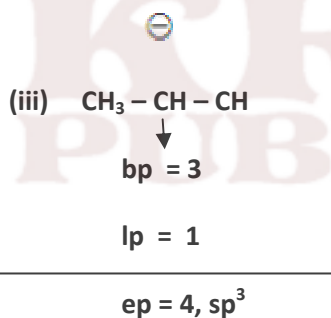

REACTION INTERMEDIATES

Reaction intermediates are generated by the breaking of covalent bond of the substrate. They are short lived species and are highly reactive. There are six important types of reaction – intermediates.

(1) Carbocation (2) Carbanion (3) Free radical (4) Carbene (5) Benzyne and (6) Nitrene

Carbocations

(1) An organic species which has a carbon atom bearing six electrons in its outermost orbit and has a positive charge is called a carbocation.

(2) carbocation can be classified into the following groups:

(A) **Alkyl carbocation** : (i) When positive charge is present on the alkyl on the carbon. carbocation is known as alkyl carbocation .

(ii) Alkyl carbocation is of four types :

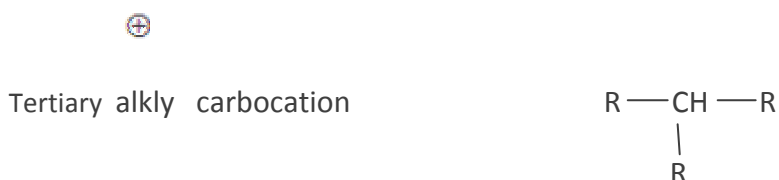

(iii) Stability of can be explained by

(i) Inductive effect and

(ii) Hyperconjugation

(iv) According to these two effect the stability order is as follows :

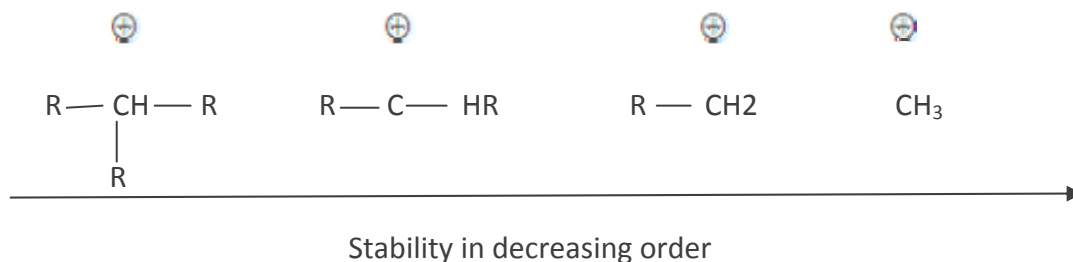

(3) stability of different types of carbocations in decreasing order :

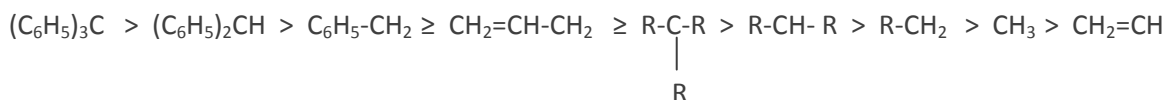
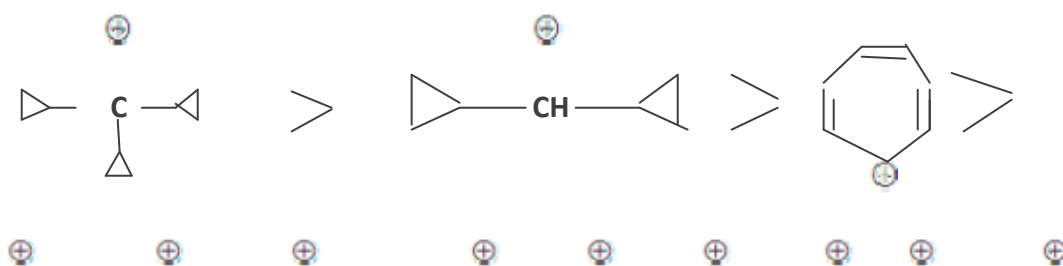

(4) Characteristics of carbocations(except vinyl carbocation) :

- (i) It has three bond pair with empty p -orbital. Its hybridisation is sp^2 .
- (ii) Shape of carbocation is trigonal planer.



Note : Triphenyl methyl carbocation has propeller shape.

- (iii) There are six electrons in the outermost orbit of carbocationic carbon hence its octet is incomplete. All the six electrons are paired.
- (iv) It is charged electrophile.
- (v) It is diamagnetic in character.
- (vi) It is formed by heterolytic bond fission
- (vii) It reacts with nucleophiles.

Carbanions

Anions of carbon is known as carbanion . carbanion carries three bond pair and one lone pair ,thus making the carbon atom negatively charged. So carbanion may be represented as

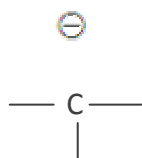

(1) Characteristic of Carbanions :

(i)

Hybridisation and geometry : alkyl carbanion has three bond pair and one lone pair. Thus hybridization is sp^3 and geometry is pyramidal.



Note : geometry of allyl and benzyl carbanion is almost planar and hybridization in sp^2 .

- (ii) There are eight electrons in the outer most orbit of carbanion carbon hence its octet is complete.
- (iii) It behaves as a charged nucleophile.
- (iv) It is diamagnetic in character because all eight electrons are paired.
- (v) It is formed by heterolytic bond fission.
- (vi) It reacts with electrophiles.

Stability of Carbanions: The stability of Carbanions may be explained by

(A) Electronegativity of Carbanionic carbon : Stability \propto Electronegativity of Carbanionic carbon

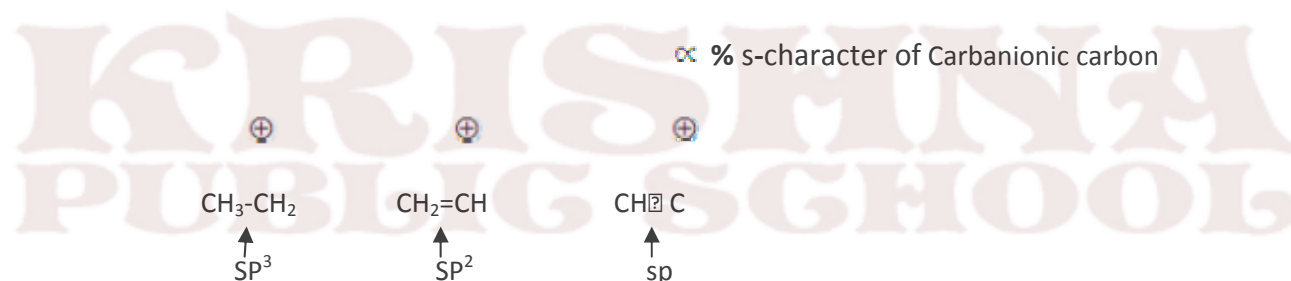

(i) % s-character in increasing order

(ii) stability in increasing order

(B) Inductive effect: stability of carbanions depends on the +I or -I group as follows:

(i)

Stability \propto

1

+I power of the group

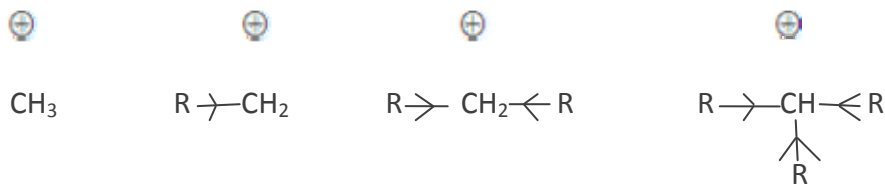

(i) +I power in increasing order

(ii) stability in decreasing order

(ii) Stability of Carbanions \propto -I power of the group

For example :



(i) -I power of halo group is in increasing order

(ii) stability in increasing order

(C) Delocalisation or Resonance: Allyl and benzyl Carbanions are stabilized by delocalization of negative charge.

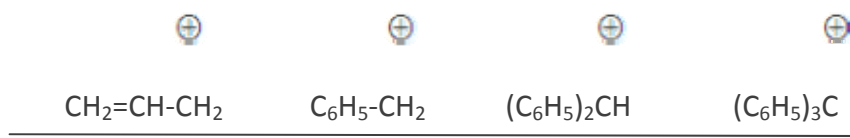

(i) Number of resonating structures is in increasing order

(ii) stability in increasing order

QUESTIONS

Q1. What type of defect can arise when a solid is heated?

Q2. Write two application of adsorption.

Q3. What is the basic principle of zone refining of metals?

Q4. Why is ICl more reactive than I_2 .

Q5. Write down the formula of Tetraamineaquachloridocobalt(III)chloride.

Q6. Arrange the following in increasing order of boiling point:

(i) $CH_3CH_2CH_2CH_2Br$

(ii) $(CH_3)_3C.Br$

(iii) $(CH_3)_2.CH.CH_2.Br$

Q7. Write the IUPAC name of the following:

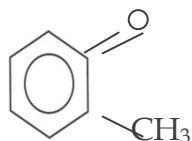

Q8. Aldehydes and Ketones have lower boiling points than corresponding alcohols. Why?

Q9. Why do gases nearly always tend to be less soluble in liquid as the temperature is raised?

Q10. Write down the structures and names of the products formed when D-glucose is treated with

(i) Bromine water

(ii) Hydrogen Iodide (Prolonged heating)

Q11. How is the stability of a co-ordination compound in solution decided? How is the dissociation constant of a complex defined?

Q12. Illustrate the following reactions :

(a) Sandmeyer's reaction

(b) Coupling reaction

Q13. (a) Name the only vitamin which can be synthesized in our body. Name the disease that is caused due to the deficiency of this vitamin.

(b).State two functions of carbohydrates.

Q14. The extraction of gold by leaching with NaCN involves both oxidation and reduction. Justify giving chemical equations.

Q15. (a) Which form of sulphur shows paramagnetic behavior and why?

(b). Fluorine exhibits only -1 oxidation state whereas other halogens exhibit +1,+3,+5 and +7 oxidation state also. Explain as to why.

Q16. What is meant by rate of a reaction ? Differentiate between average rate and instantaneous rate of a reaction.

Q17. How would you account for the following :

(a) Aniline is a weaker base than cyclohexylamine.

(b) Methylamine in aqueous medium gives reddish- brown precipitate with FeCl_3 .

OR

How would you account for the following :

(a) Electrophilic substitution in case of aromatic amines takes place more readily than benzene.

(b) Ethanamide is a weaker base than ethanamine.

Q18. Write the reaction taking place at cathode and anode in lead storage battery when the battery is in use. What happens on charging the battery?

Q19. (a) What are intrinsic semi-conductors ? Give an example.

(b) What is the distance between Na^+ and Cl^- ions in NaCl crystal if its density is 2.165 g cm^{-3} ? [Atomic Mass of Na = 23u, Cl = 35.5u; Avogadro's number = 6.023×10^{23}]

Q20. (a) How many coulombs are required to reduce 1 mole $\text{Cr}_2\text{O}_7^{2-}$ to Cr^{3+} ?

(b) The conductivity of 0.001M acetic is $4 \times 10^{-5} \text{ S/m}$. Calculate the dissociation constant of acetic acid if Λ_m^0 for acetic acid is $390 \text{ S cm}^2 \text{ mol}^{-1}$

Q21. What are the following substances? Give one example of each.

(i) Broad spectrum antibiotics

(ii) Narcotic analgesics

(iii) Synthetic detergents

Q22. Explain the term co-polymerization and give two examples copolymers and the reactions for their preparations.

Q23. (a) How would you obtain the following:

(i) 2-methylpentan-2-ol from 2-methyl-1-pentene

(ii) Acetophenone from phenol

(b) Write IUPAC name of the following:

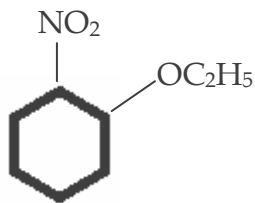

Q24. In general it is observed that the rate of a chemical reaction doubles with every 10 degree rise in temperature. If the generalization holds good for the reaction in the temperature range 295 K to 305 K, what would be the value of activation energy for this reaction ? [R = $8.314 \text{ mol}^{-1} \text{ K}^{-1}$]

Q25. How are the two types of emulsions different from one another ? Give suitable examples to justify the difference. State two applications of emulsion.

Q26. Account for the following :

- (a) The dipole moment of chlorobenzene is lower than that of cyclohexyl chloride.
- (b) Alkyl halides, though polar, are immiscible with water.
- (c) Grignard's reagents should be prepared under anhydrous conditions.

Q27. If N_2 gas is bubbled through water at 293 K, how many millimoles of N_2 gas would dissolve in 1 liter of water? Assume that N_2 exerts a partial pressure of 0.987 bar. Given that Henry's law constant for N_2 at 293 K is 76.48.

OR

The partial pressure of ethane over a saturated solution containing 6.56×10^{-2} g of ethane is 1 bar. If the solution contains 5.0×10^{-2} g of ethane, then what will be the partial pressure of the gas?

Q28. (a) Give chemical tests to distinguish between the following pairs of compounds:

(i) Benzamide and 4-aminobenzoic acid

(ii) Methyl acetate and Ethyl acetate

(b) An organic compound with molecular formula $C_9H_{10}O$ forms 2,4-DNP derivative and reduces Tollen's reagent and undergoes Cannizzaro's reaction. On vigorous oxidation, it gives 1,2-benzenedicarboxylic acid. Identify the compound and write chemical equations for the reactions.

OR

(a) Give chemical tests to distinguish between the following pairs of compounds:

(i) Benzoic acid and Phenol

(ii) Benzaldehyde and Acetophenone

(b) An organic compound with molecular formula $C_5H_{10}O$ does not reduce Tollen's reagent but forms an addition compound with sodium hydrogen sulphite and gives a positive iodoform test. On vigorous oxidation, it gives ethanoic acid and propanoic acid. Identify the compound and write all chemical equations for the reactions.

Q29. Account for the following :

- (i) Chlorine water loses its yellow colour on standing.
- (ii) BrCl_2 is more stable than BrCl_5 .
- (iii) Fluorine does not form oxoacids.
- (iv) PCl_5 acts as an oxidizing agent.
- (v) SO_2 is an air pollutant.

OR

(a) With help of chemical equations the principle of contact process in brief for the manufacture of sulphuric acid. (No diagram)

(b) Account for the following :

- (i) Bond dissociation energy of F_2 is less than that of Cl_2 .
- (ii) Nitric oxide (NO) becomes brown when released in air.

Q30. (a) Describe the preparation of potassium dichromate from chromite ore. What is the effect of change of pH on dichromate ion?

(b) How is the variability in oxidation state of transition elements different from that of non-transition elements? Illustrate with examples.

OR

(a) Describe the preparation of potassium permanganate from pyrolusite ore. What happens when acidified potassium permanganate solution reacts with ferrous sulphate solution? Write balanced chemical equations.

(b) Account for the following :

- (i) Mn^{2+} compounds are more stable than Fe^{2+} compounds towards oxidation to their +3 state.
- (ii) Cr^{2+} is reducing and Mn^{3+} oxidizing when both have d^4 configuration.

ANSWERS

1. Metal excess defect
2. (a) In chromatography for the separation of mixtures .
(b) Adsorption toxic gases by activated charcoal or gas masks.(or any other correct application)
3. this method is based on the principle that the impurities are more soluble in the melt than the solid of the metal.
4. Because of low bond dissociation enthalpy.
5. $[\text{Co}(\text{NH}_3)_4(\text{H}_2\text{O})\text{Cl}]\text{Cl}_2$
6. $(\text{CH}_3)_3\text{CBr} > (\text{CH}_3)_2\text{CHCH}_2\text{Br} > \text{CH}_3\text{CH}_2\text{CH}_2\text{CH}_2\text{Br}$
7. 2-methylcyclohexanone
8. Because of the absence of hydrogen bonding in aldehydes and ketones.
9. As the temperature rises the value of Henry's law constant, K_H increases Solubility of gas in liquids decreases with increase in K_H .
10. (i)
$$\begin{array}{c} \text{COOH} \\ | \\ (\text{CHOH})_2 \\ | \\ \text{CH}_2\text{OH} \end{array}$$

Gluconic acid

(ii) $\text{CH}_3\text{-(CH}_2\text{)}_4\text{-CH}_3$
n-hexane
11. Stability of a coordination compound in solution is decided by its stability constant K . Larger is the stability constant, higher will be the stability of complex formed. The reciprocal of the formation constant is known as the *dissociation constant*.(or any other correct answer)

12. Sadmeyer's reaction

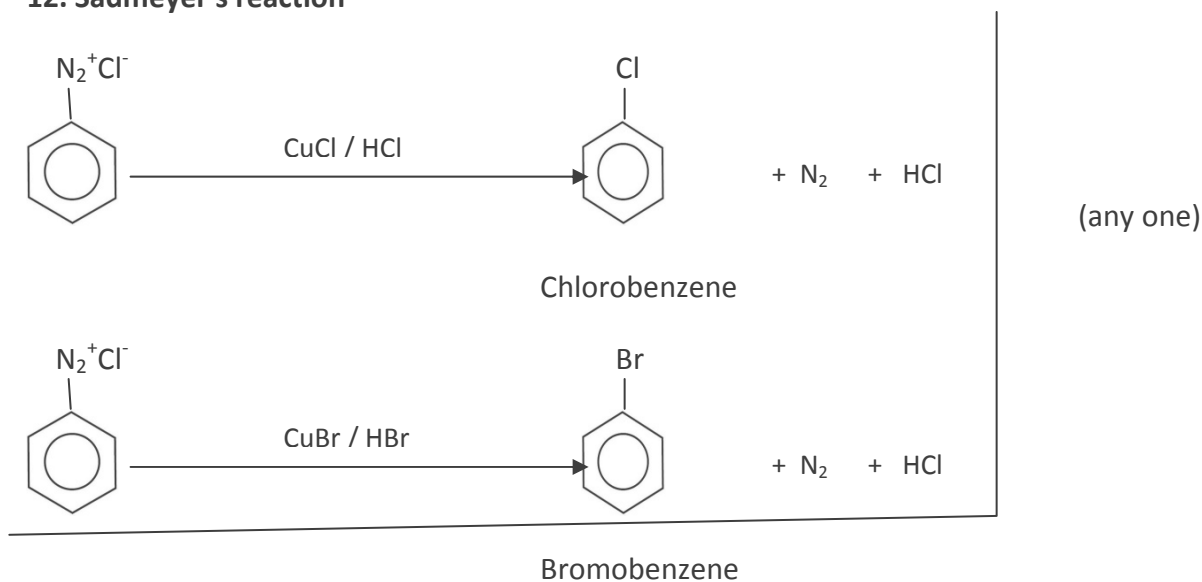

(i) Coupling reaction



13. (a) Vitamin D, Rickets

(b) (i) Carbohydrates act as a structural material for plant cell walls.

(ii) They act as a reserve food material. (or any other correct function)

14. Oxidation

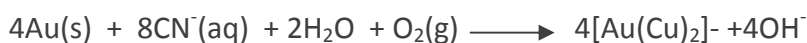

Reduction



Note: Molecular equation can be accepted.

15. (a) In vapour phase sulphur shows paramagnetic behavior due to the presence of 2 unpaired electrons.

b) Because fluorine is most electronegative and does not have vacant d-orbitals.

16. Decrease or increase (change) in the concentration of reaction with time is known as the rate of reaction.

Average rate is measured in larger time intervals whereas instantaneous rate is measured in shortest time intervals (at a particular instant of time).

17. (ii) It is because in aniline the $-\text{NH}_2$ group is attached directly to the benzene ring. It results in the unshared electron pair on nitrogen atom to be in conjugation with the benzene ring and thus making it less available for protonation. (or any other suitable reason)

(iii) Methyl amine in water gives OH^- ions which react with FeCl_3 to give precipitate of ferric hydroxide

or

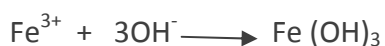
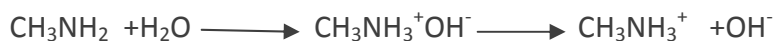

OR

(a) because $-\text{NH}^2$ is a very strong activating group due to the presence of lone pair of electrons on nitrogen/ or due to resonance in atomic amines.

(b) Because NH^2 of ethanamide involves in resonance with carbonyl group ($-\text{CO}-$) which leads to positive charge on N and less basic.

18. Anode Reaction :- $\text{Pb} + \text{SO}_4^{2-} \longrightarrow \text{PbSO}_4(\text{s}) + 2\text{e}^-$

Cathode Reaction :- $\text{PbO}_2 + 4\text{H}^+ + \text{SO}_4^{2-} + 2\text{e}^- \longrightarrow \text{PbSO}_4 + 2\text{H}_2\text{O}$

On charging the battery the reaction is reversed.

19. (a) The pure substances in which electrical conductivity is due to the thermal promotion of valence electrons to the conduction band are called intrinsic semi-conductors. Eg Si / Ge (any one correct example)

(b) $d = z \times M$

$a^3 \times N_A$ For fcc lattice $z=4$

$$2.165 \text{ g cm}^{-3} = \frac{4 \times 58.5 \text{ g mol}^{-1}}{a^3 \times 6.023 \times 10^{23} \text{ mol}^{-1}}$$

$$a^3 = \frac{4 \times 58.5 \text{ g mol}^{-1}}{2.165 \text{ g cm}^{-3} \times 6.023 \times 10^{23} \text{ Mol}^{-1}}$$

$$a = 5.64 \times 10^{-8} \text{ cm or } 564 \text{ pm}$$

Therefore the distance between Na^+ and Cl^- ions is $564/2=282 \text{ pm}$

20. (a) $6F = 6 \times 96500 C = 5.76 \times 10^5 C$

(b) $\Delta m = K/c = \frac{4 \times 10^{-7} \text{ cm}^{-1} \times 1000 \text{ cm}^3 \text{ L}^{-1}}{0.001 \text{ mol L}^{-1}} = 0.4 \text{ Scm}^2 \text{ mol}^{-1}$

$$\alpha = \frac{\Delta m}{\Delta m^0} = \frac{0.4 \text{ Scm}^2 \text{ mol}^{-1}}{390 \text{ Scm}^2 \text{ mol}^{-1}} = 0.00103$$

$$K = \frac{C\alpha^2}{C(1-\alpha)} = C\alpha^2 = 0.001 \times (0.00103)^2 = 1.06 \times 10^{-9}$$

21. (i) Broad Spectrum Antibiotics; which killers inhibit a wide range of Gram +ve and Gram -ve are called broad spectrum antibiotics. Eg. Chloramphenicol (or any one correct example)

(ii) Narcotic Analgesics : The medicines which when administered relieve pain and produce sleep are called narcotic analgesics.

eg. Morphine (or any one correct example)

(iii) Synthetic Detergents : are cleansing agents which have all the properties of soap but which actually do not contain any soap

eg. Sodium Lauryl sulphate (or any one correct example)

22. (i) The polymer made by addition polymerization from two different monomers are termed as co-polymers and the process is called co-polymerization.

Eg. Bune-S , Buna-N (or any one correct example)

Bune-S



Buna-N

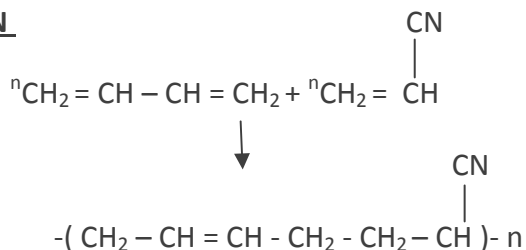

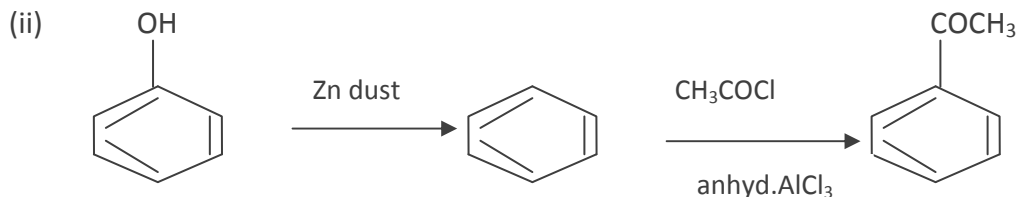
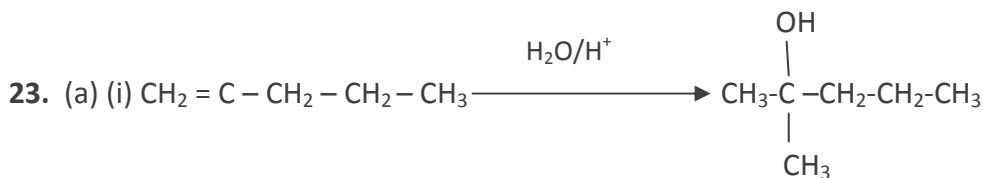

(b) 1 - ethoxy - 2 - nitrocyclohexane

24. (b) $\log \frac{k_2}{k_1} = \frac{E_a}{2.303 R} \left[\frac{T_2 - T_1}{T_1 T_2} \right]$

$$\log 2 = \frac{E_a}{2.303 \times 8.314 \text{ jk}^{-1} \text{ mol}^{-1}} \left[\frac{305 - 295}{305 \times 295} \right] \text{K}^{-1}$$

$$0.30010 = \frac{E_a}{2.303 \times 8.314 \text{ jk}^{-1} \text{ mol}^{-1}} \frac{10 \text{K}^{-1}}{305 \times 295}$$

$$E_a = 51855.2 \text{ j mol}^{-1} \text{ or } 51.86 \text{ k j mol}^{-1}$$

25. (i) **Oil in water** : The emulsion in which oil is dispersed phase and water is dispersion medium eg. Milk is an emulsion of fats in water

(ii) **Water in oil**: the emulsion in which water is dispersed phase and oil is dispersion medium . eg. Butter , cod liver oil

Applications: (i) Cleansing action of soaps and detergents

(ii) concentration of sulphide ones by Froth Floatation Process. (or any one correct applic

26. (a) Due to $-\text{I}$ and $-\text{R}$ effect of Cl group , the net dipole reduces to a large extent in chlorobenzene . (or diagrammatic explanation)

(b) Because alkyl halides can not form hydrogen bond with water.

(c) Because in the presence of moisture it change to alkane .(or chemical reaction)

$$27. x(\text{Nitrogen}) = \frac{p(\text{nitrogen})}{K_H} = \frac{0.987 \text{ bar}}{76,480 \text{ bar}} = 1.29 \times 10^{-5}$$

As 1 litre of water contains 55.5 mol of it, therefore if n represents number of moles of N_2 in solution,

$$x(\text{Nitrogen}) = \frac{n \text{ mol}}{n \text{ mol} + 55.5 \text{ mol}} = \frac{n}{55.5} = 1.29 \times 10^{-5}$$

(n in denominator is neglected as it is $\ll 55.5$)

Thus $n = 1.29 \times 10^{-5} \times 55.5 \text{ mol} = 7.16 \times 10^{-4} \text{ mol}$

$$= \frac{7.16 \times 10^{-4} \text{ mol} \times 1000 \text{ mol}}{1 \text{ mol}} = 0.716 \text{ m mol}$$

OR

Applying Henry's law

$$m = k_H \times p, \quad 6.56 \times 10^{-2} \text{ g} = k_H \times 1 \text{ bar}$$

$$k_H = 6.56 \times 10^{-2} \text{ g bar}^{-1}$$

put the value of k_H in the second case

$$5 \times 10^{-2} = 6.56 \times 10^{-2} \text{ g bar}^{-1} \times p$$

$$P = \frac{5 \times 10^{-2} \text{ g}}{6.56 \times 10^{-2} \text{ g bar}^{-1}} = 0.765 \text{ bar}$$

KRISHNA
PUBLIC SCHOOL

28. (a) (i) Add NaHCO_3 to both the compounds, 4-aminobenzoic acid will give brisk effervescence whereas Benzamide will not give this test. (or any other correct suitable test)

(ii) Warm both the esters with NaOH and then heat them with I_2 and NaOH . Ethyl acetate gives yellow ppt of Iodoform. (or any other correct suitable test)

(b)

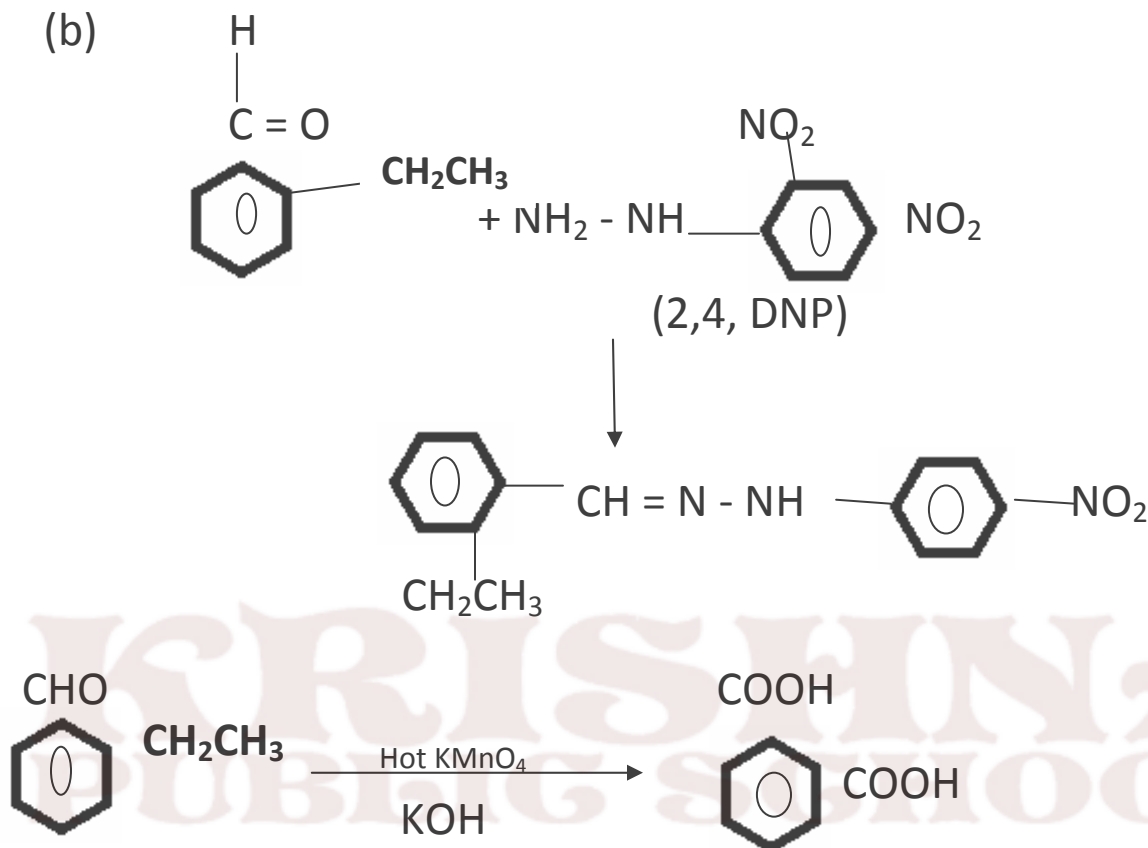

OR

(a) (i) **Phenol and Benzoic acid:** Add neutral FeCl_3 to both of them. Phenol gives violet colour. (Other relevant test can be accepted)

(b) As the compound does not reduce Tollen's reagent but forms an addition compound with NaHSO_3 therefore compound gives positive contains a ketone group. Since compound gives positive iodoform test therefore compound contains CH_3CO group.

On vigorous oxidation compound gives ethanoic acid and propanoic acid which shows the compound $\text{C}_5\text{H}_{10}\text{O}$ is $\text{CH}_3\text{CH}_2\text{CH}_2\text{COCH}_3$ (pentan-2-one)



(or the given reaction can be explained by the equation)

29. (i) Because of the formation of HOCl / or due to its oxidation.
- (ii) Because of inert pair effect.
- (iii) Because of high electronegativity of fluorine.
- (iv) Because +3 oxidation state of P is more stable than +5.
- (v) Because in air SO₂ gets oxidized to H₂SO₄ which is very corrosive and poisonous

CONTACT PROCESS

- i) burning of sulphur or sulphide ores in air to generate SO₂.
- (ii) conversion of SO₂ to SO₃ by the reaction with oxygen in the presence of a catalyst (V₂O₅), and
- (iii) absorption of SO₃ in H₂SO₄ to give *Oleum* (H₂S₂O₇).

A flow diagram for the manufacture of sulphuric acid is shown in
The SO₂ produced is purified by removing dust and other impurities such as arsenic compounds.

The key step in the manufacture of H₂SO₄ is the catalytic oxidation of SO₂ with O₂ to give SO₃ in the presence of V₂O₅ (catalyst).



The reaction is exothermic, reversible and the forward reaction leads to a decrease in volume. Therefore, low temperature and high pressure are the favourable conditions for maximum yield. But the temperature should not be very low otherwise rate of reaction will become slow.

- (b) (i) Because of large electron - electron pair repulsion among the lone pair in F₂ molecule.
- (ii) because of the formation of NO₂ gas.

30. (a) it is prepared from one called chromate or ferro chrome iron, $\text{FeO} \cdot \text{Cr}_2\text{O}_3$. The various steps involved are

(i) preparation of sodium chromate

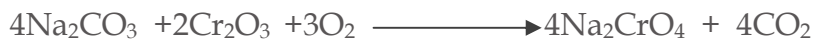

(ii) Conversion of sodium chromate in to sodium dichromate.

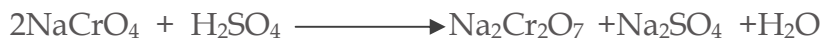

(iii) Conversion of sodium dichromate in to potassium dichromate



Dichromate ion ($\text{Cr}_2\text{O}_7^{2-}$) converts to chromate ion (CrO_4^{2-}) in the presence of alkali (i.e. $\text{pH} > 7$) or ionic equation.

(b) In transition elements oxidation state differ from each other by unity eg. V^{2+} , V^{3+} , V^{4+} , V^{5+}

Whereas in non-transition elements oxidation state normally differ by a unit of two eg. Cl^- , Cl^+ , Cl^{3+} , Cl^{5+} (or any one correct example)

OR

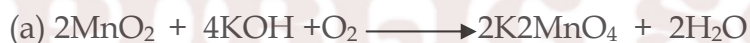

HALOALKANES , HALOARENES

1- Important terms and concept



(i) Halogen derivative of alkenes called halo alkenes e.g. R-CH₃

(ii) Halogen derivative of arenes called halo arenes e.g. R-C₆H₅

2. (a) Vicinal di halides - where the two halogens are attached on the adjacent carbon atom.

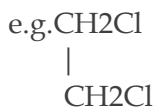

(b) geminal dihalide- where two halogen atoms are attached to the same carbon atom eg
CH₃CHBr₂

2- Important mechanism

(i) Nucleophilic substitution

(ii) Electrophilic substitution

(iii) Elimination reaction

(iv) Carbylamine reaction

(v) Reimer Tiemann reaction

(vi) Wurtz reaction

(vii) Wurtz fittig reaction

Nucleophilic substitution it involves the replacement of an atom or group by another atom or group



It must be remembered that A - B and A - C both are covalent compounds.

(i) In aliphatic system



Decreasing order of Basicity CH₃ > NH₂ > O-R > OH > I > Br > Cl

In general



Bimolecular Nucleophilic substitution SN²

(i) It takes place in one step.

(ii) Most of the SN² reaction are second order but some time when Nucleophilic reagent is present in excess quantity the reaction is of I_{ts} order but still proceeds by SN²

(iii) It is bimolecular

(iv) It leads to inversion of configuration attack of Nucleophilic occur from direction opposite to the leaving group.



SN¹ → (i) It takes place in two steps.

(ii) All are 1st order.

(iii) Unimolecular

(iv) It leads racemisation Retention

(v) Retention of configuration

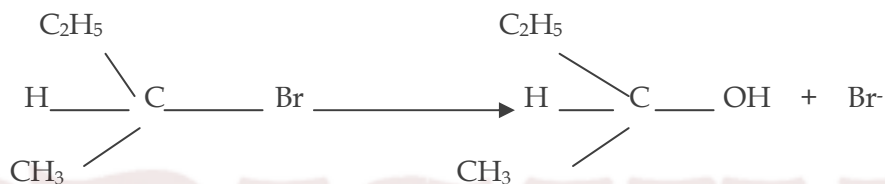

The preservation of spatial arrangement of bonds at an asymmetric centre during the chemical reaction.

Stereochemistry of SN¹ reaction

If an alkyl halide is optically active then the product is racemic mixture, here the attack of Nucleophiles from the both side [50:50 mix of the two enantiomers].

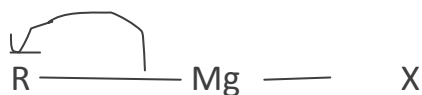
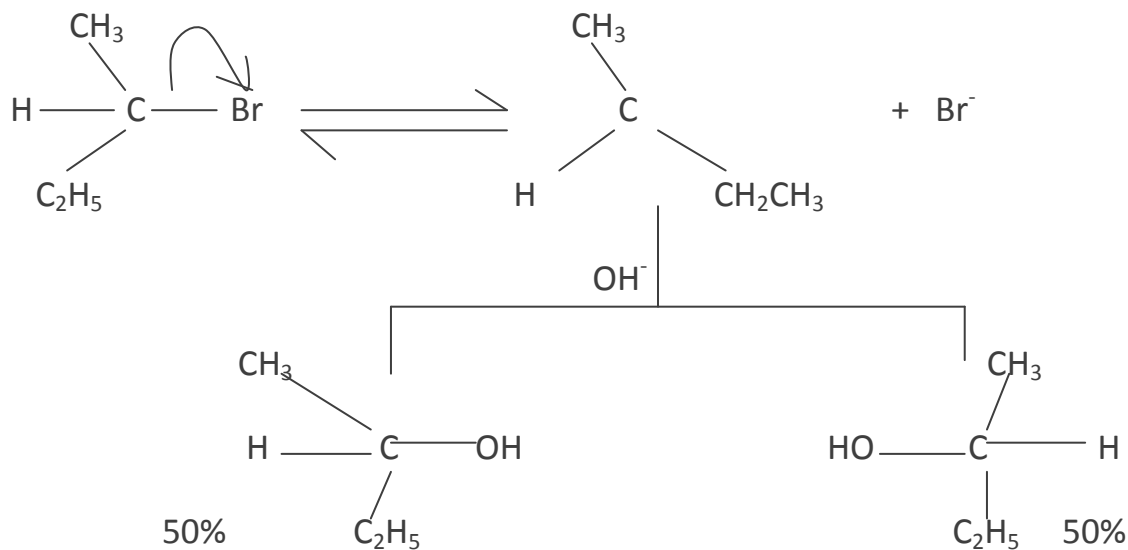

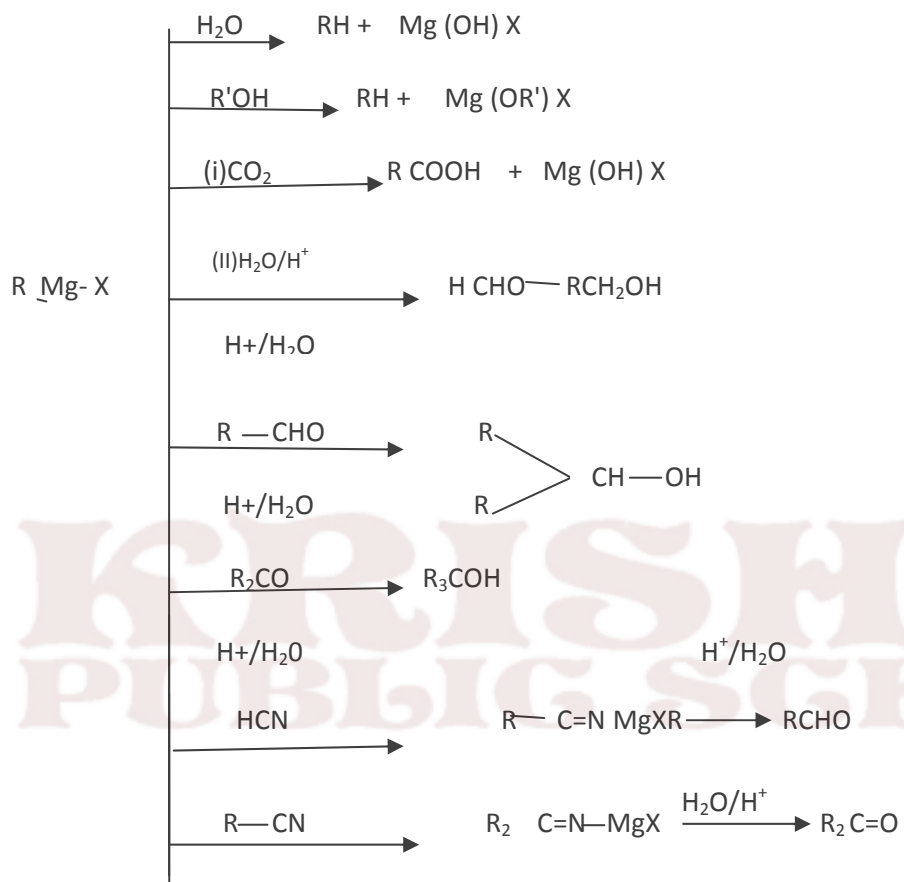

KRISHNA
 PUBLIC SCHOOL

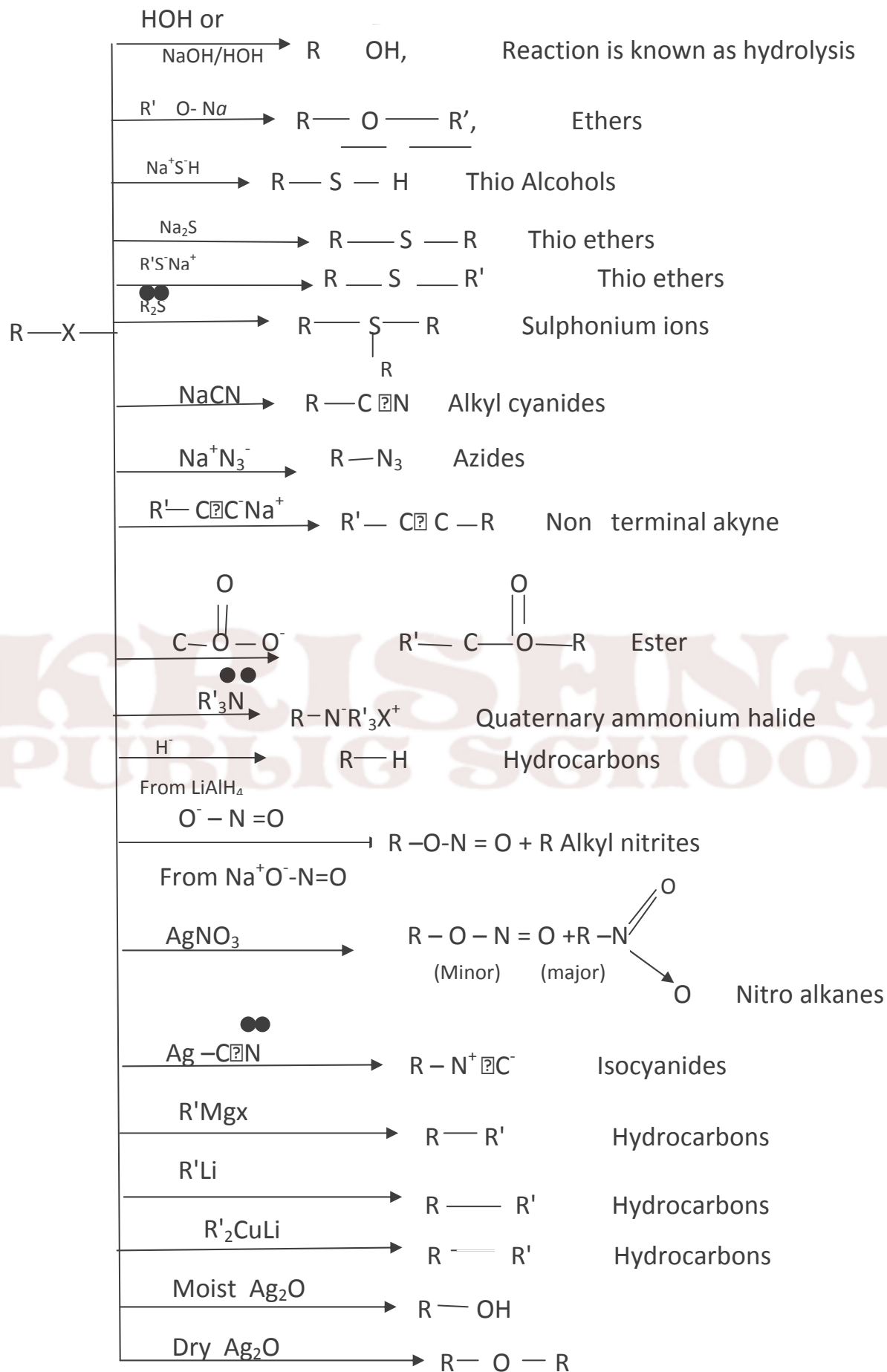

Electrophilic substitution sees in aromatic compound mech.

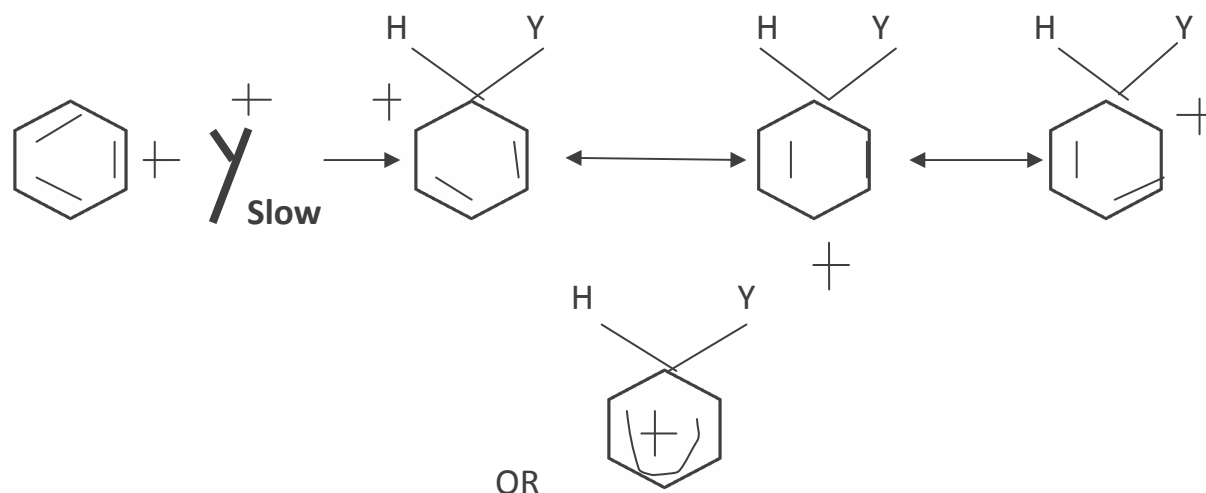

E.g. Nitration - how Electrophiles produce.



OR

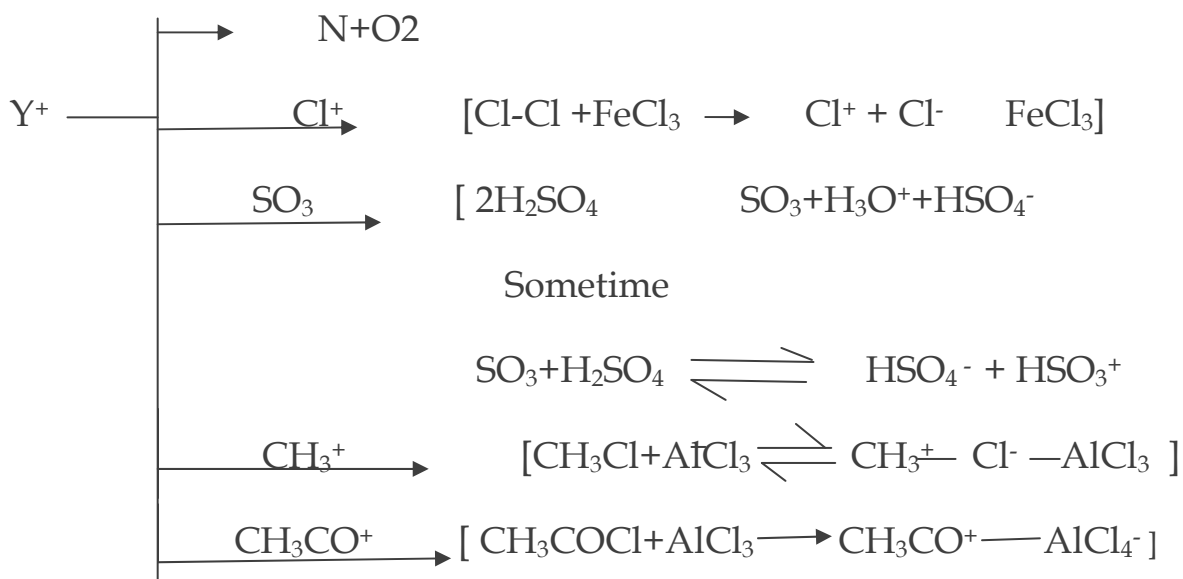

Elimination reaction

Two groups or atoms attached to two adjacent carbon atom and simultaneous formation of multiple bonds between these carbon atom. [Reverse of addition]

Two types (i) β . Elimination -

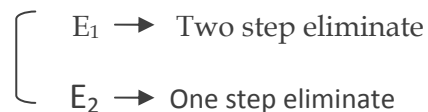

(ii) α -elimination

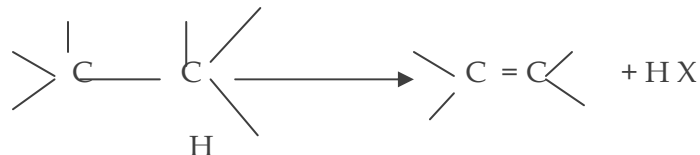

Saytzaiff's Rule

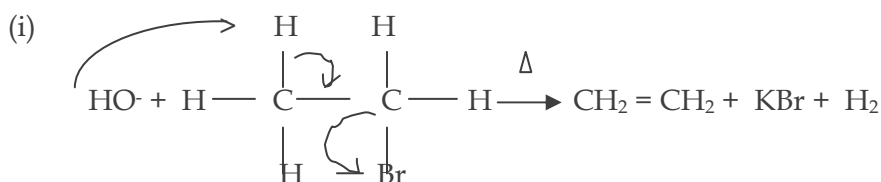

81% More highly substituted Alkenes,
More stable

Some important name reaction

1. **Carbylamines reaction.**



2. **Reimer Tiemann Reaction**

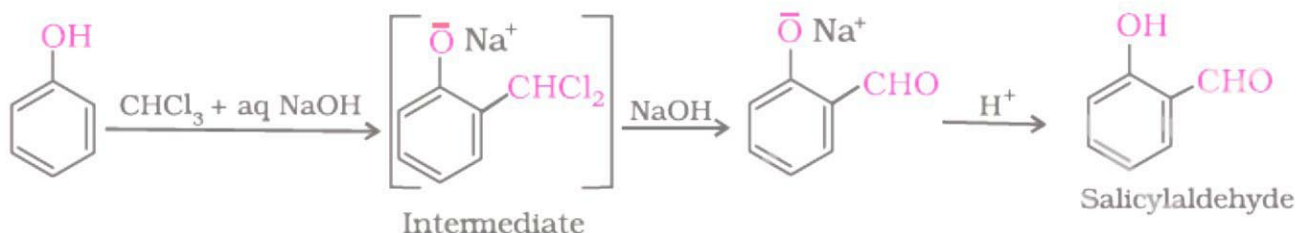

3. **Haloform reaction**

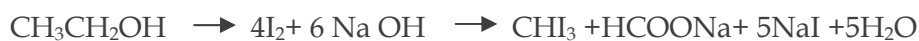

4. **Wurtz reaction**



WurtzFITTIG REACTION

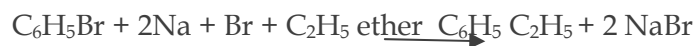

Coupling reac.

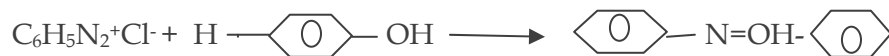

Diazonium Salt

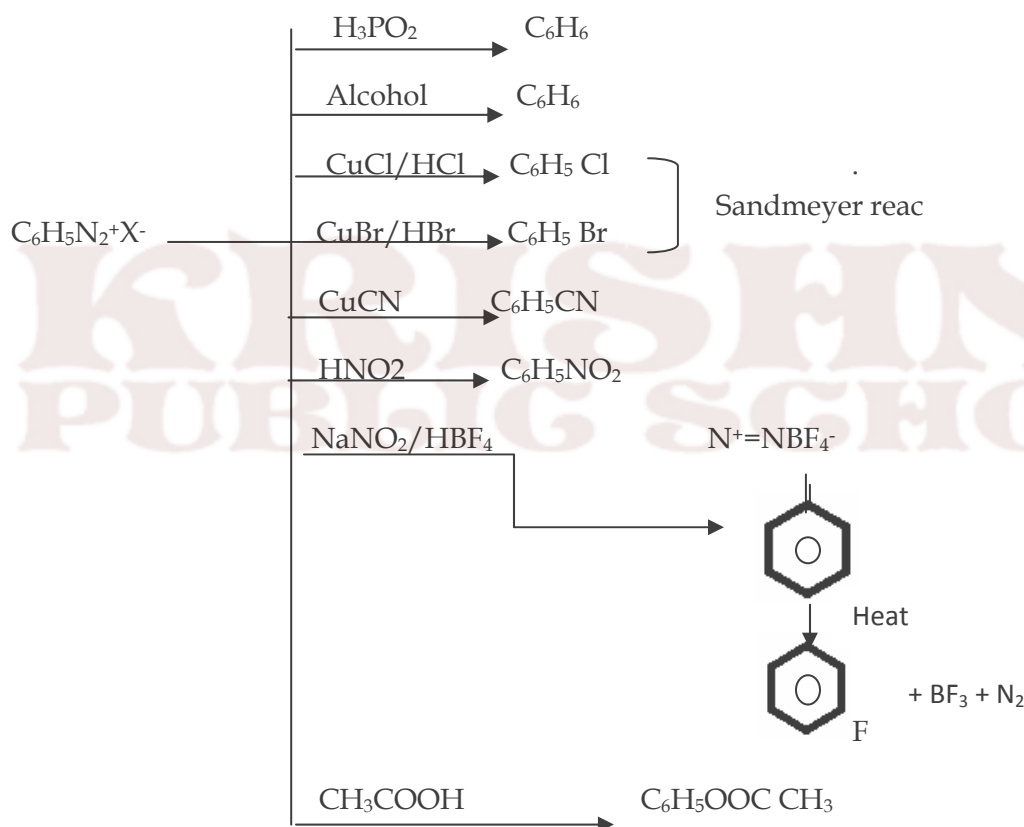

CONCEPTUAL QUESTIONS

Q1. Why haloalkanes are more reactive than haloarenes.

Ans. In haloarenes, there is double bond character b/w carbon and halogen due to resonance effect which makes him less reactive.

(ii) In benzene, carbon being sp² hybridised which is smaller in size than sp³ present in haloalkanes. So C-Cl bond in aryl halides is shorter and stronger.

Q2. Why do haloalkenes under go nucleophilic substitution whereas haloarenes under go electrophilic substitution .

Ans. Due to more electro negative nature of halide atom in haloalkanes carbon atom becomes slightly positive and is easily attacked by nucleophilic reagents.

While in haloarenes due to resonance, carbon atom becomes slightly negative and attacked by electrophilic reagents.

Q3. When an alkyl halide is treated with ethanolic solution of KCN, the major product is alkyl cyanide where as if alkyl halide is treated with AgCN, the major product is alkyl isocyanide.

Ans. KCN is ionic they can attach through C or N but C-C bond is strong than C-N bond. So alkyl cyanide is the major product but AgCN is covalent so more electronegative N can attach to C and forms isocyanides.

Q4. How do 1^o 2^o 3^o alcohols differ in terms of dehydrogenation?

Ans. 1^oalcohol $\xrightarrow{\text{Cu, 300}^{\circ}\text{C}}$ aldehyde

2^oalcohol $\xrightarrow{\text{Cu, 300}^{\circ}\text{C}}$ ketone

3^oalcohol $\xrightarrow{\text{Cu, 300}^{\circ}\text{C}}$ alkene

Q5. Why are the reaction of alcohol/phenol with acid chloride in the presence of pyridine ?

Ans. Because esterification reaction is reversible and presence of base (pyridine) neutralises HCl produced during reaction thus promoting forward reaction .

Q6. Explain why o-nitrophenol is more acidic than o-methoxy phenol ?

Ans. -NO₂ group is electron withdrawing group, e⁻ density on O decreases and loss of H⁺ is easy whereas -OCH₃ group is electron releasing group, which increases e⁻ density on O, which makes difficult to the loss of H⁺, hence are less acidic .

Q7. Aryl halides cannot be prepared by the action of sodium halide in the presence H₂SO₄ .Why?

Ans. Due to resonance the carbon-oxygen bond in phenols has partial double bond and it is stronger than carbon oxygen single bond.

Q8. Why Grignard reagent should be prepared under anhydrous conditions.?

Ans. Grignard reagent react with H₂O to form alkanes, therefore they are prepared under anhydrous condition.

Q9. Why is Sulphuric acid not used during the reaction of alcohols with KI ?

Ans. It is because HI formed will get oxidized to I₂ by concentrated Sulphuric acid which is an oxidizing agent.

Q10. p- dichlorobenzene has highest m.p. than those of ortho and m-isomers.?

Ans. p- dichlorobenzene is symmetrical, fits into crystal lattice more readily and has higher melting point.

Q11. Although chlorine is an electron- withdrawing group, yet it is ortho and para directing in electrophilic aromatic substitution reactions.Why

Ans. Chlorobenzene is resonance hybrid, there is -ve charge at o and para positions, electrophilic substitution reaction will take place at o and para position due to +R effect. +R effect is dominating over -I effect. .

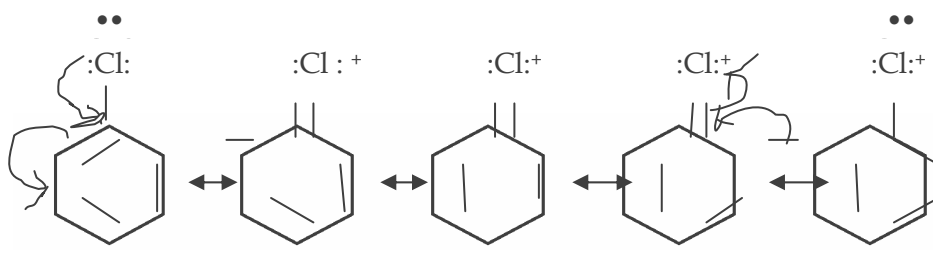

Q12. The treatment of alkyl chlorides with aqueous KOH lead to the formation of alcohols but in presence of alcoholic KOH alkenes are major products. Explain?

Ans. In aqueous KOH, OH⁻ is nucleophile which replaces another nucleophile.



Where as in alcoholic KOH

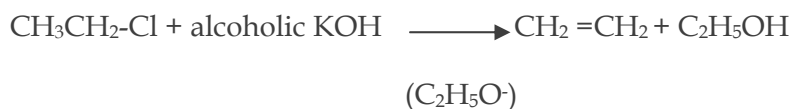

Q13. Explain why vinyl chloride is unreactive in nucleophilic substitution reaction?

Ans. Vinyl chloride is unreactive in nucleophilic substitution reaction because of double bond character between C=Cl bond which is difficult to break.



Q14. Arrange the following compounds according to reactivity towards nucleophilic substitution reaction with reagents mentioned :-

- (i) 4- nitro chloro benzene, 2,4 di nitro chloro benzene, 2,4,6, trinitrochlorobenzene with CH₃ONa

Ans- 2,4,6, trinitrochlorobenzene > 2,4 dinitrochlorobenzene > 4- nitrochlorobenzene

Q15. Which compound will react faster in S_N2 reaction with OH^- ?

Ans- (a) CH_3Br and CH_3I (S_N2)

CH_3I will react faster than CH_3Br

(b) $(CH_3)_3C-Cl$ or CH_3Cl (S_N2)

CH_3Cl will react faster than 3° halide

Q16. Arrange in order of boiling points.

(a) Bromobenzene, Bromoform, chloromethane, Dibromo-methane

(b) 1-chloropropane, Isopropyl chloride, 1-Chlorobutane.

Ans. (a) chloromethane < Bromobenzene < Dibromo-methane < , Bromoform

(b) , Isopropyl chloride < 1-chloropropane < 1-Chlorobutane

(As Branching increases , boiling point decreases)

Q 17. Predict the reactivity in S_N1

(a) $C_6H_5CH_2Br$, $C_6H_5CH(C_6H_5)Br$, $C_6H_5CH(CH_3)Br$, $C_6H_5C(CH_3)(C_6H_5)Br$

Ans. $3^\circ > 2^\circ > 1^\circ$ (S_N1)

$C_6H_5C(CH_3)(C_6H_5)Br > C_6H_5(C_6H_5)Br > C_6H_5CH(CH_3)Br > C_6H_5CH_2Br$

(3°)

(2°)

(2°)

(1°)

Q18. Which compound undergoes S_N1 reaction first ?

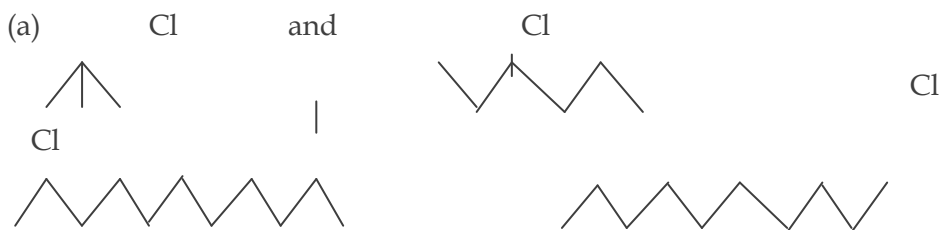

(a) Ans. $3^\circ > 2^\circ > 1^\circ$ (S_N1)

(b) (2°)

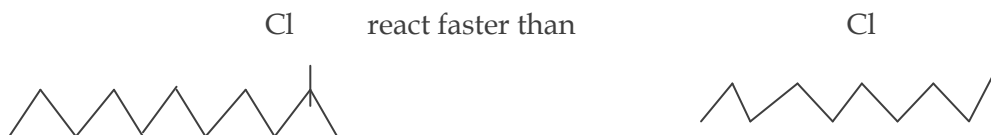

VERY SHORT ANSWER TYPE QUESTION

[1 MARKS]

Q.1. Write the formula & chemical name of DDT?

Q.2. An alkyl halide having molecular formula C_4H_9Cl is optically active. what is its structure?

Q.3. Why is vinyl chloride less reactive than ethyl chloride?

Q.4. Write the structural isomers of $C_3H_6Cl_2$ which can exhibit enantiomerism ?

Q.5. Write down the structure of the following compounds;

(a) 1- chloro-4-ethyl cyclohexane

(b) 1,4-dibromo but-2-ene

(c) 4-tert, butyl-3-iodoheptane

(d) 1-bromo-4-secbutyl-2-methylbenzene

Q.6. Which compound $(CH_3)_3C-Cl$ or CH_3Cl will react faster in S_N2 reaction with $-OH^-$?

Q.7. A hydrocarbon C_5H_{10} does not react with chlorine in dark but it gives a single monobromo compound in bright sunlight. identify the compound.

Q.8. Why is sulphuric acid not used during the reaction of alcohols with KI?

Q.9. Out of $C_6H_5CH_2Cl$ & $C_6H_5CH_2Cl$ which is more easily hydrolysed with aq. KOH & why ?

Q.10. Chloroform is stored in dark coloured & sealed bottle. why?

Short answer type questions

Q.1. Give the IUPAC names of the following compounds?

A) $ClCH_2C = CCH_2Br$

b) $(CCl_3)_3CCl$

C) $CH_3CH(Cl)CH(Br)CH_3$

Q.2. Starting from methyl iodine, how will you prepare :

A) nitromethane

B) methyl nitrite

Q.3. How can iodoform be prepared from ethanol ?

Q.4. predict the product of the following reactions;

Q.5. write the reaction involved in :

A) the isocyanide test

Q 2. Alcohols reacts with halogen acids to form haloalkenes but phenol does not form halobenzene.

Explain

. Ans. The C-O bond in phenol acquires partial double bond character due to resonance and hence be cleared by X⁻ ions to form halobenzenes. But in alcohols a pure C – O bond is maintained and can be cleared by X⁻ ions.

Q 3. Explain why o-nitrophenol is more acidic than o-methoxy phenol?

Ans . Due to – R and – I effect of – NO₂ group, e⁻ density on =O' if O – H bond decreases and loss of H⁺ is easy. – I effect In contrast, in o-methoxy phenol due to + R effect, – OCH₃ increases. e⁻ density on O² of O – H group, and hence loss of H⁺ is difficult.(both -ve charge repel each other)

Q4. Of benzene and phenol, which is more easily nitrated and why?

Ans. Nitration is an electrophilic substitution. The –OH group in phenol increases the electron density at ortho and para position as follows Since phenol has higher electron density due to electron releasing nature of –OH group , compared to benzene , therefore nitration is easy in phenol than benzene.

Q5. How will you account for the following? Ethers possess a net dipole moment even if they are symmetrical in structure?

A. Because of greater electronegativity of o- atom than carbon C – O bonds are polar. C – O bond are inclined to each other at an angle of 110° (or more), two dipoles do not cancel out each other.

Q 6. How do 1°, 2° and 3° alcohols differ in terms of their oxidation reaction and dehydrogenation ?

Ans. (I) Oxidation reaction : (O) (O)

1° alcohol → aldehyde → carboxylic acid (O) (O)

2° alcohol → ketone → carboxylic acid (acid with loss of 1 carbon atom) (O)

3° alcohol → resistant to oxidation

(II) Hydrogenation reaction : give

1° alcohol → aldehyde

2° alcohol → ketone

3° alcohol → alkene 3° alcohols prefer to undergo dehydration and form alken

Q7. (i)How is diethyl ether prepared from ethyl alcohol?

Ans. Ethyl alcohol is first treated with sodium to form sodium ethoxide



Sodium ethoxide is then treated with ethyl halide to form di ethyl ether. SN²



(II) Complete the reaction:

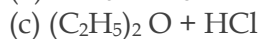

A. (a) $2 \text{CH}_3\text{Cl}$ (b) $\text{CH}_3\text{Cl} + \text{C}_2\text{H}_5\text{OH}$ (c) $\text{C}_2\text{H}_5\text{Cl} + \text{C}_2\text{H}_5\text{OH}$

Q8. Why are reactions of alcohol/phenol and with acid chloride in the presence of pyridine?

Ans. Because esterification reaction is reversible and presence of base (pyridine) neutralises HCl produced during reaction thus promoting forward reaction.

LONG ANSWER TYPE QUESTIONS

Q1) How the following conversions can be carried out?

- (i) Propene to propan-1-ol
- (ii) 1-Bromopropane to 2-bromopropane
- (iii) Toluene to benzyl alcohol
- (iv) Benzene to 4-bromonitrobenzene
- (v) Benzyl alcohol to 2-phenylethanoic acid

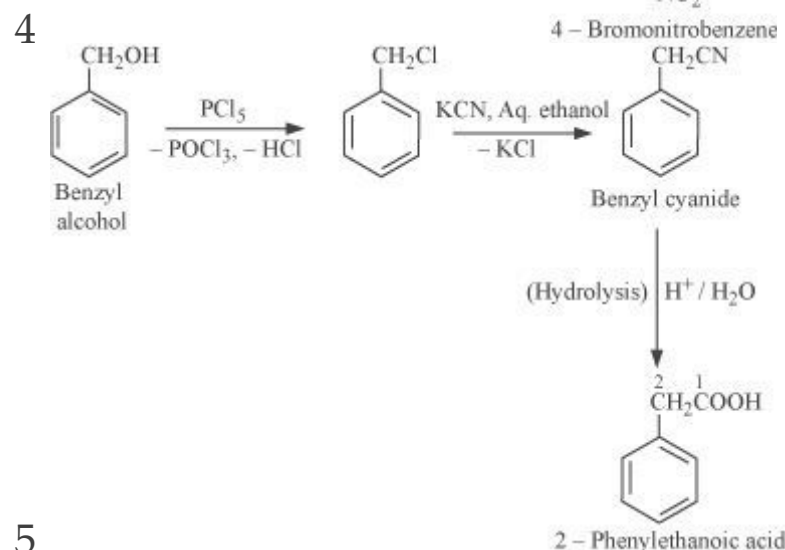
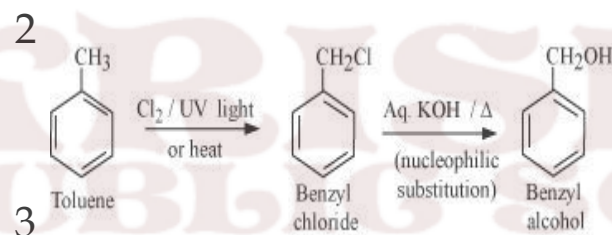
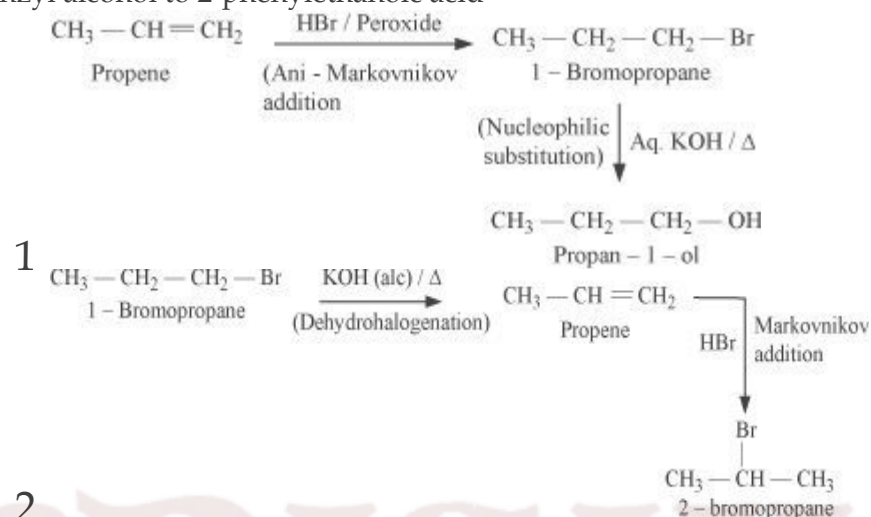

5

Q3) How the following conversions can be carried out?

- (i) But-1-ene to n-butyliodide
- (ii) 2-Chloropropane to 1-propanol
- (iii) Isopropyl alcohol to iodoform
- (iv) Chlorobenzene to p-nitrophenol
- (v) 2-Bromopropane to 1-bromopropane

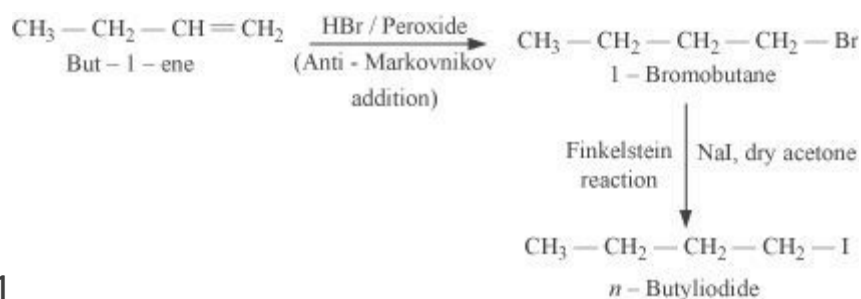

11

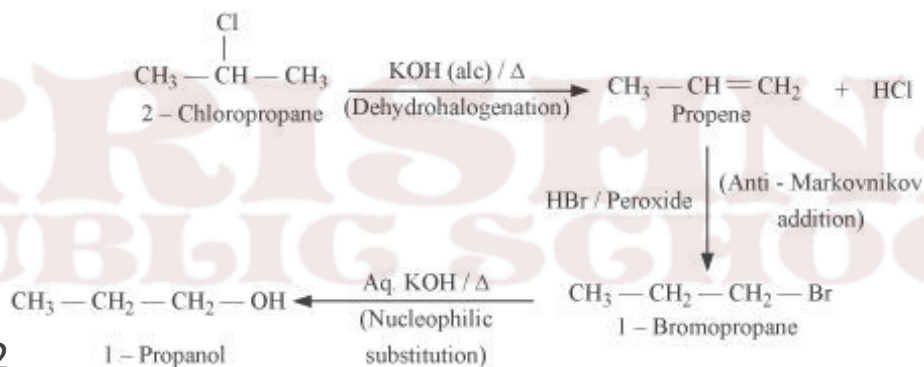

12

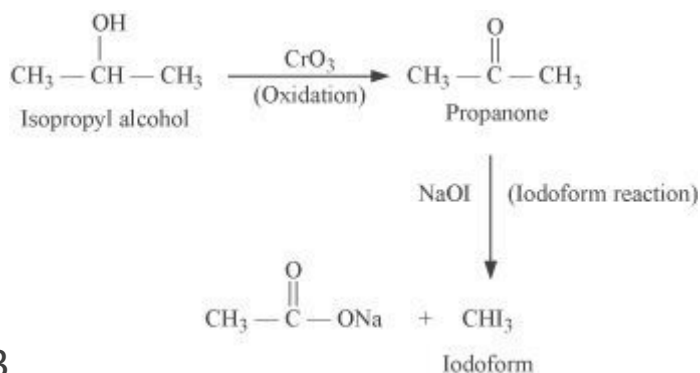

13

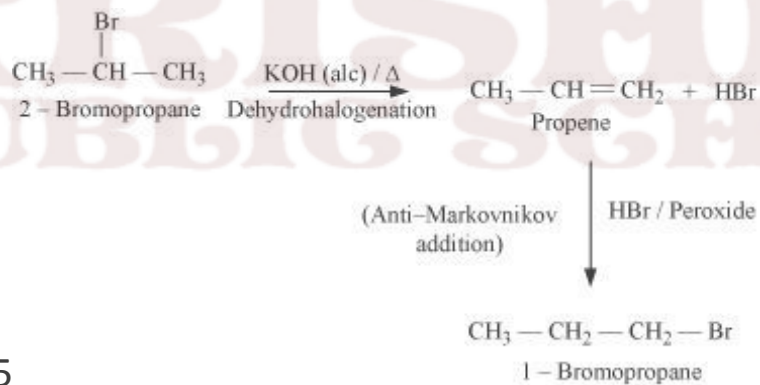
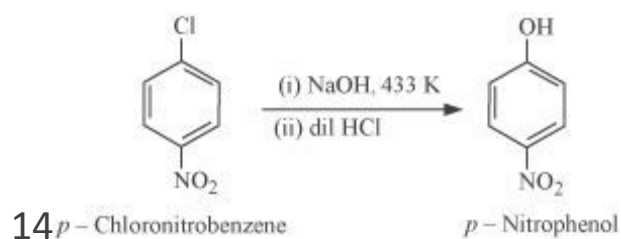
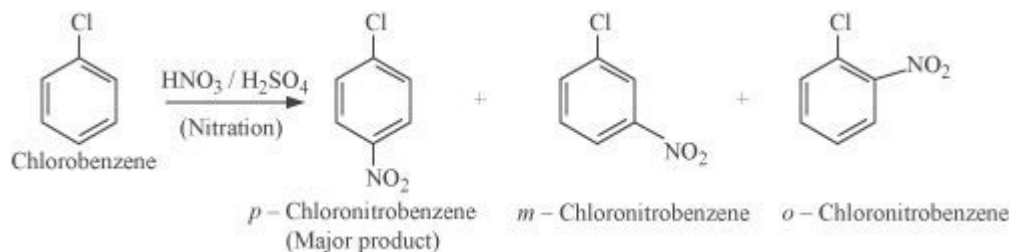

Q4) How the following conversions can be carried out?

(i) Chloro ethane to butane

(ii) Benzene to diphenyl

(iii) tert-Butyl bromide to isobutyl bromide

(iv) Aniline to phenylisocyanide

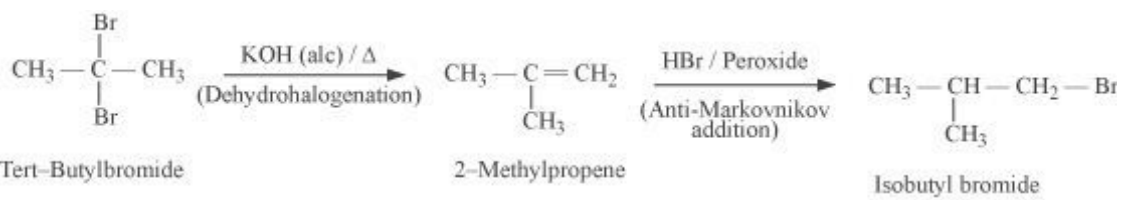
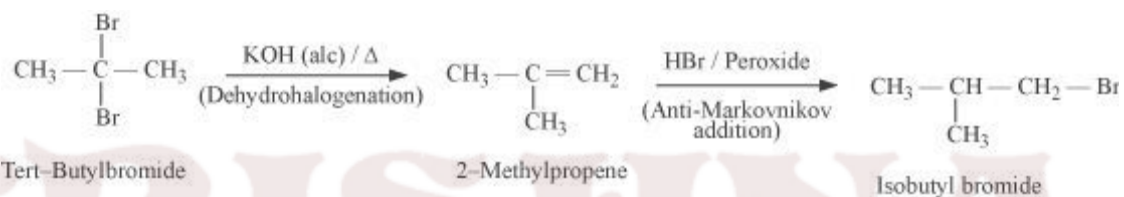
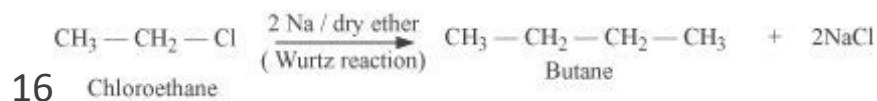

19

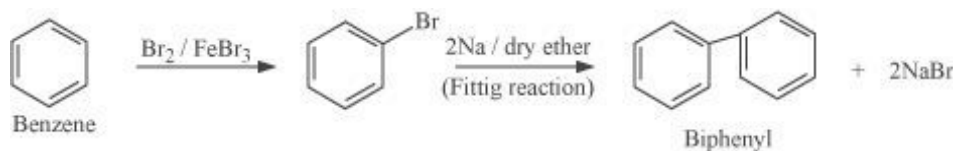

ALCOHOLS PHENOLS AND ETHERS

Family	Functional group	Example
Alcohol	$R - O - H$	CH_3OH methanol
Phenol	$Ar - O - H$	C_6H_5OH Phenol
Ether	$\begin{array}{c} \quad \\ -C - O - C- \\ \quad \\ \quad O \end{array}$	methylether CH_3OCH_3
Aldehyde	$-CHO$	Acetaldehyde CH_3CHO
Ketone	$\begin{array}{c} \quad \quad \\ -C - C - C- \\ \quad \end{array}$	Acetone CH_3COCH_3
Carboxylic acid	$\begin{array}{c} \\ -C - O - H \end{array}$	Acetic acid CH_3COOH
Ester	$\begin{array}{c} O \quad H \\ \quad \\ -C - O - C - H \\ \\ H \end{array}$	Ester $CH_3 - COOCH_3$ Methyl / acetate
Amide	$\begin{array}{c} \\ -C - N - H \\ \\ H \end{array}$	acetamide CH_3CONH_2
Acid Anhydride	$\begin{array}{c} \quad O \\ -C - O - C- \\ \end{array}$	$CH_3COOCOCH_3$ acetic anhydride
Acid chloride	$\begin{array}{c} O \\ \\ -C - X \end{array}$	acetyl chloride $CH_3 - \begin{array}{c} O \\ \\ C - Cl \end{array}$

IUPAC Name

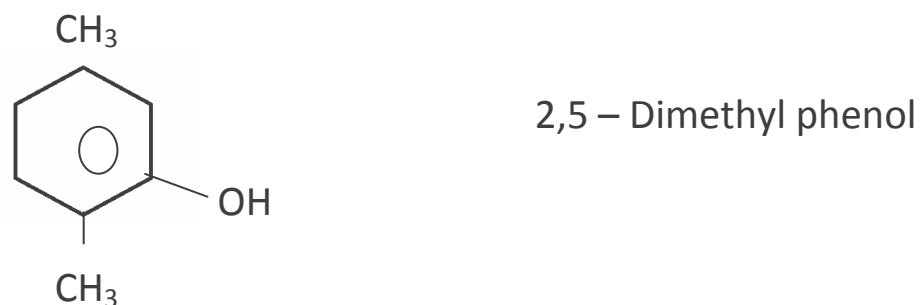
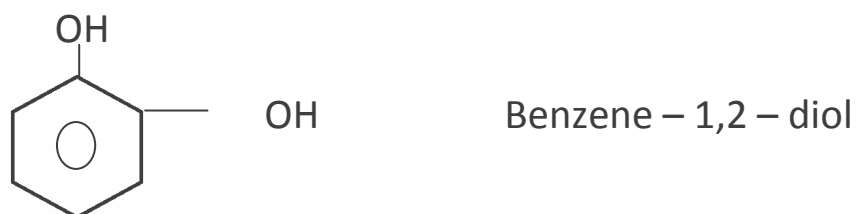
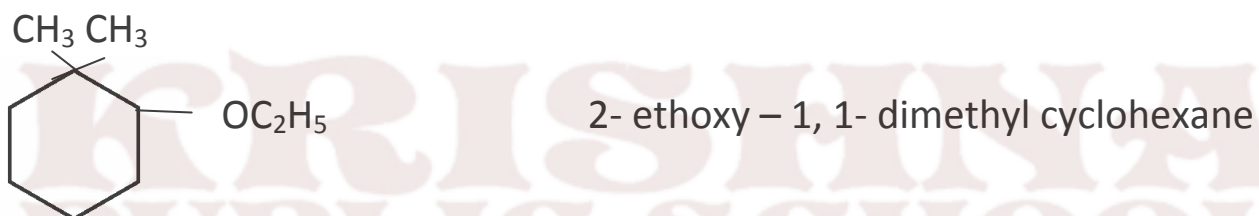
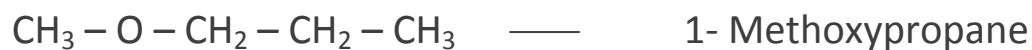

$\text{CH}_3 - \text{OH}$	Methanol
$\text{CH}_3 - \text{CH}_2 - \text{CH}_2 - \text{OH}$	Propan-1-ol
$\begin{array}{c} \text{CH}_3 - \text{CH} - \text{CH}_3 \\ \\ \text{OH} \end{array}$	Propan-2-ol
$\text{CH}_3 - \text{CH}_2 - \text{CH}_2 - \text{CH}_2 - \text{OH}$	Butan-1-ol
$\begin{array}{c} \text{CH}_3 - \text{CH} - \text{CH}_2 - \text{CH}_3 \\ \\ \text{OH} \end{array}$	Butan-2-ol
$\begin{array}{c} \text{CH}_3 - \text{CH} - \text{CH}_2 - \text{CH}_3 \\ \\ \text{OH} \end{array}$	2-Methylpropan-1-ol
$\begin{array}{c} \text{CH}_3 \\ \\ \text{CH}_3 - \text{C} - \text{OH} \\ \\ \text{CH}_3 \end{array}$	2-Methylpropan-2-ol
$\begin{array}{c} \text{CH}_2 - \text{CH} - \text{CH}_2 \\ \quad \quad \\ \text{OH} \quad \text{OH} \quad \text{OH} \end{array}$	Propane -1, 2, 3-triol

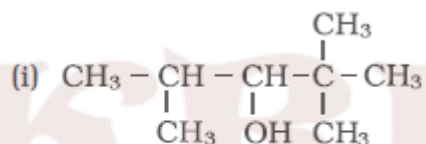

2,2,4-Trimethylpentan-3-ol

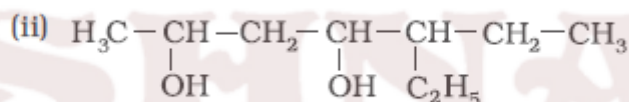

5-Ethylheptane-2,4-diol

IUPAC names of phenols

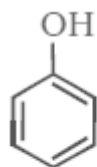

Phenol

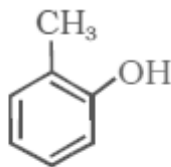

2-Methylphenol

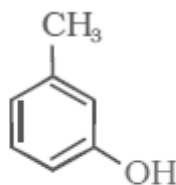

3-Methylphenol

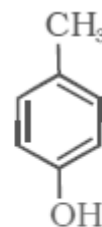

4-Methylphenol

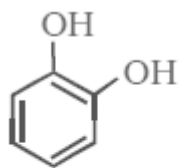

Benzene-1,2-diol

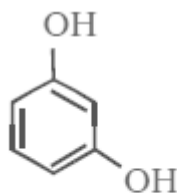

Benzene-1,3-diol

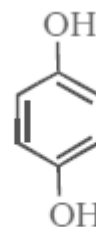

Benzene-1,4-diol

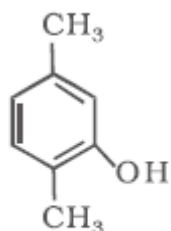

2,5-Dimethylphenol

IUPAC names of some ethers

Compound	IUPAC name
CH_3OCH_3	Methoxymethane
$\text{C}_2\text{H}_5\text{OC}_2\text{H}_5$	Ethoxyethane
$\text{CH}_3\text{OCH}_2\text{CH}_2\text{CH}_3$	1-Methoxypropane
$\text{C}_6\text{H}_5\text{OCH}_3$	Methoxybenzene (Anisole)
$\text{C}_6\text{H}_5\text{OCH}_2\text{CH}_3$	Ethoxybenzene
$\text{C}_6\text{H}_5\text{O}(\text{CH}_2)_6 - \text{CH}_3$	1-Phenoxyheptane
$\begin{array}{c} \text{CH}_3\text{O}-\text{CH}-\text{CH}_3 \\ \\ \text{CH}_3 \end{array}$	2-Methoxypropane
$\text{C}_6\text{H}_5-\text{O}-\text{CH}_2-\text{CH}_2-\underset{\text{CH}_3}{\text{CH}}-\text{CH}_3$	3- Methylbutoxybenzene
$\text{CH}_3-\text{O}-\text{CH}_2-\text{CH}_2-\text{OCH}_3$	1,2-Dimethoxyethane
	2-Ethoxy- -1,1-dimethylcyclohexane

Name reaction

- (1) Reimer Tiemann. Reaction – [See in haloalkanes]
- (2) Transesterification
- (3) Williamson synthesis
- (4) Kolbe reaction
- (5) Friedel craft

Transesterification : When an ester treated with excess of another alcohol [other than the one from which ester has been derived] in presence of corresponding sod. Or pot. Alkoxide or an acid H_2SO_4 / HCl as catalyst i.e. also cleavage by alcoholysis

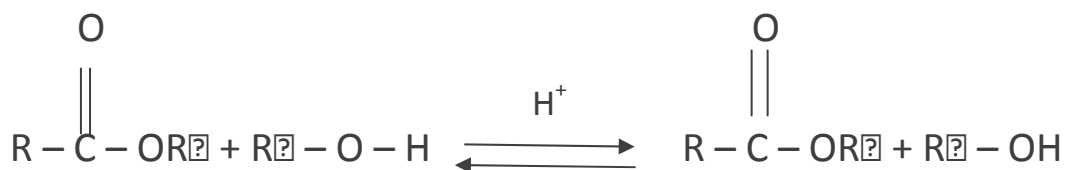

Williamson synthesis:- Reaction with alkyl halide with sodium alkoxide or sod. Phenoxide called Williamson synthesis.

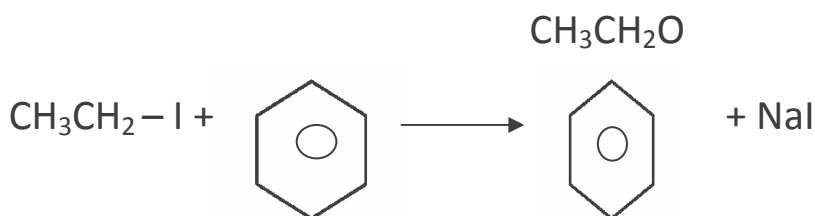

Both simple and mixed ether can be produced.

Depending upon structure and cleavage of unsymmetrical ethers by halogen acid may occur either by SN^2 or SN^1 mechanism.

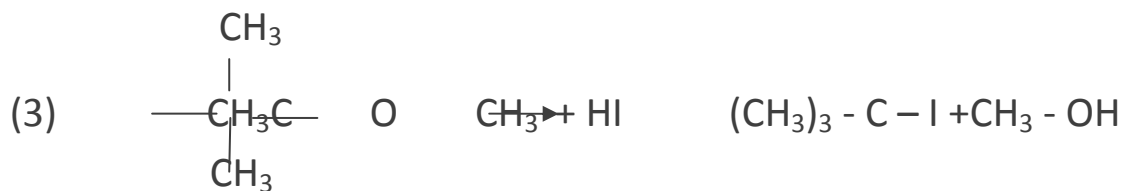
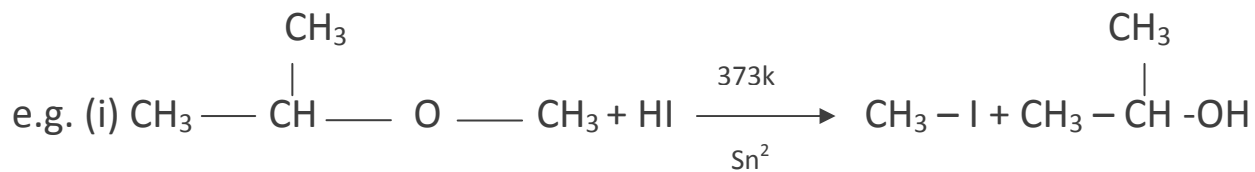

LIMITATIONS OF WILLIAMSON SYNTHESIS

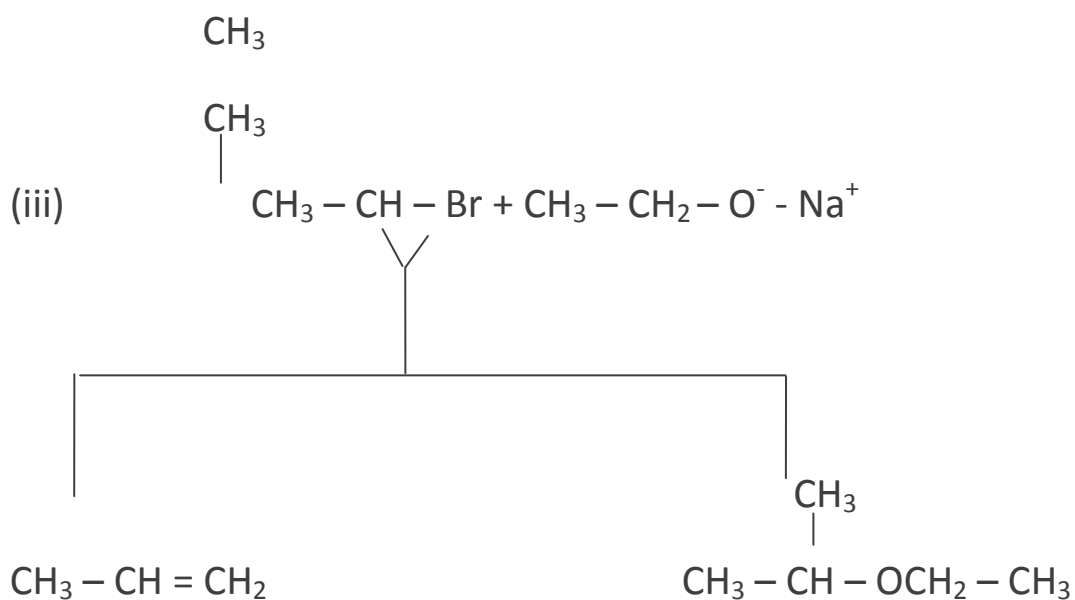
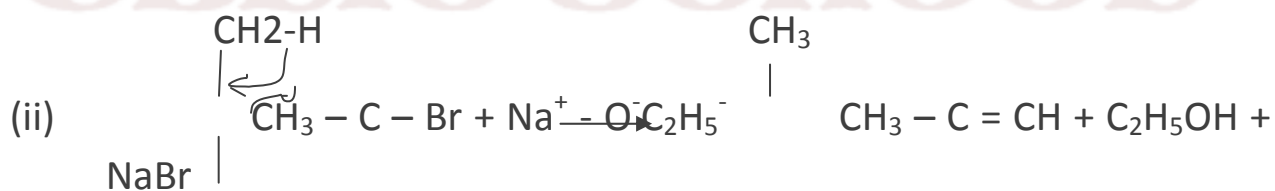
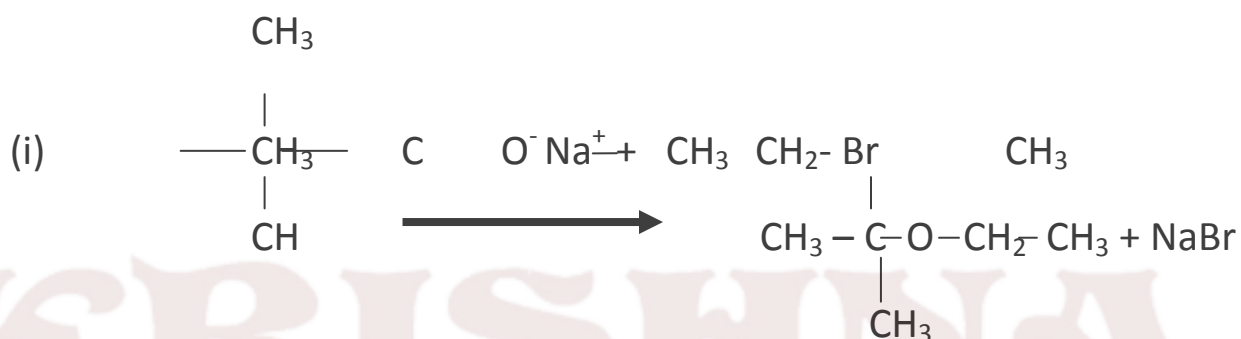

Kolbe reaction

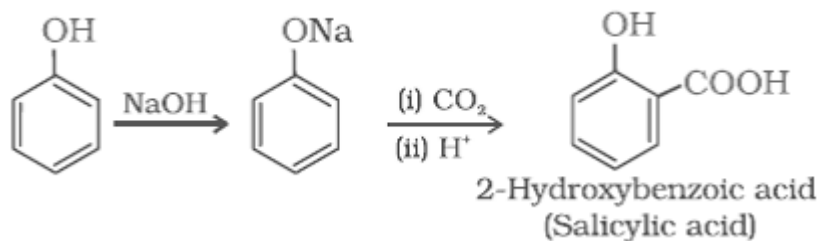

Friedel craft reaction

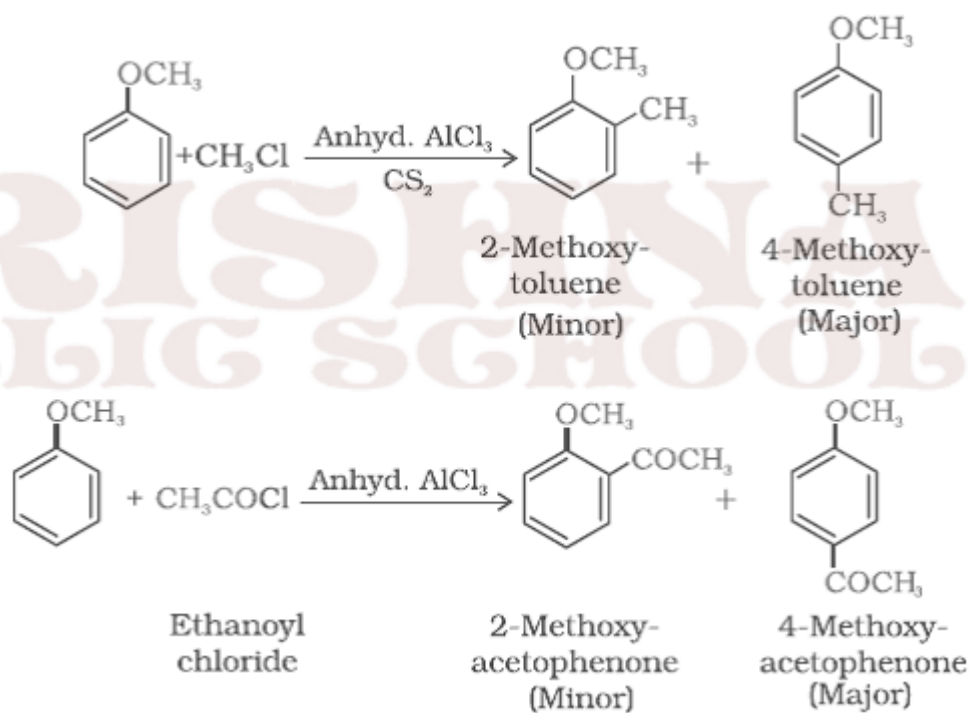

DISTINCTION BETWEEN PAIR OF COMPOUNDS

When 1^o, 2^o, and 3^o alcohol treated with Lucas reagent [con, HCL + anhydrous ZnCl₂] at room temp

- (i) If turbidity appears immediately alcohol is 3^o.
- (ii) If turbidity appears in five minutes alcohol is 2^o.
- (iii) 1^o alcohol does not react with L.R. at room temp.

(II) All those compound like alcohol, aldehyde Ketones which on oxidation giving CH₃ - CO⁻ Group undergoes iodoform test.

e.g. (i) CH₃CH₂OH

(II) CH₃-CHO

(III) (CH₃) - CH - OH

(IV) CH₃ - COCH₃

(V) C₆H₅ - CO - CH₃

(VI) CH₃ - CH - CH₂ - CH₂ - CH₃
 |
 OH

(VII) CH₃ - C - CH₂ - CH₂ - CH₃
 ||
 O

Important mechanism

(i) Hydration of alkenes



(ii)

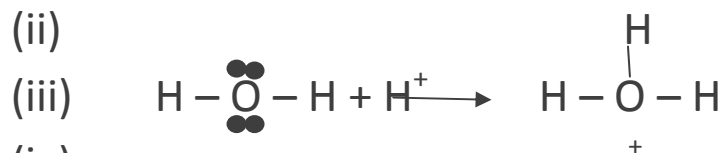

(iv)

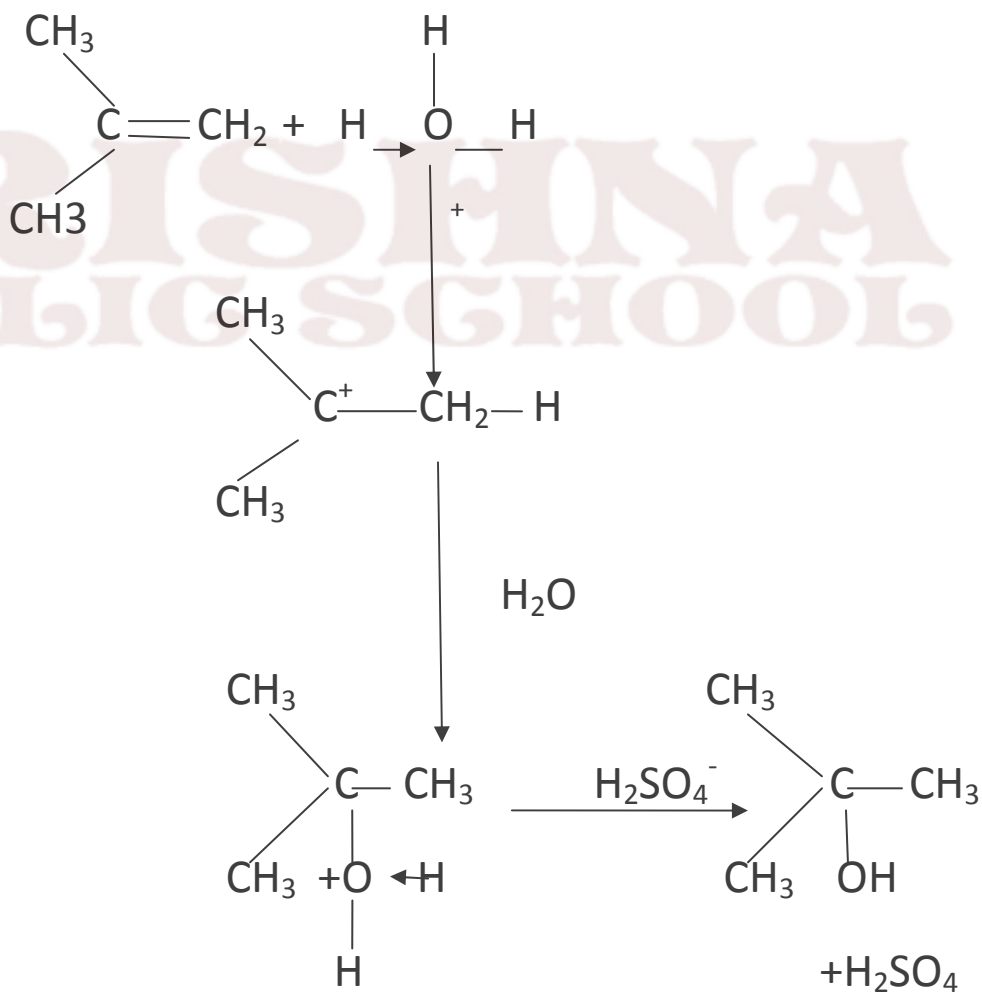

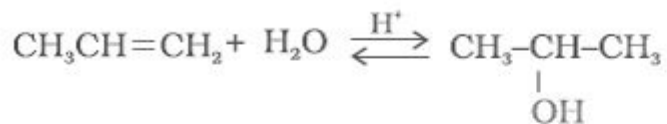
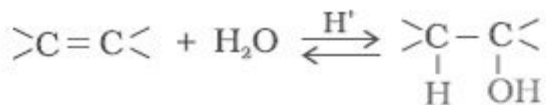

Mechanism

The mechanism of the reaction involves the following three steps:

Step 1: Protonation of alkene to form carbocation by electrophilic attack of H_3O^+ .

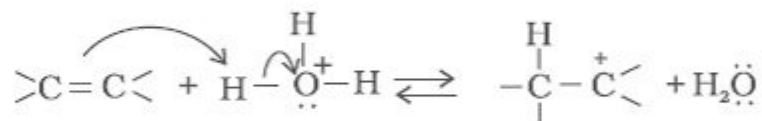

Step 2: Nucleophilic attack of water on carbocation.

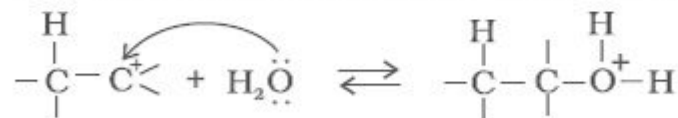

Step 3: Deprotonation to form an alcohol.

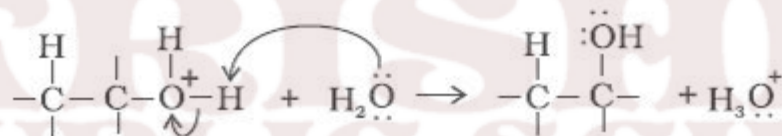

Important reaction

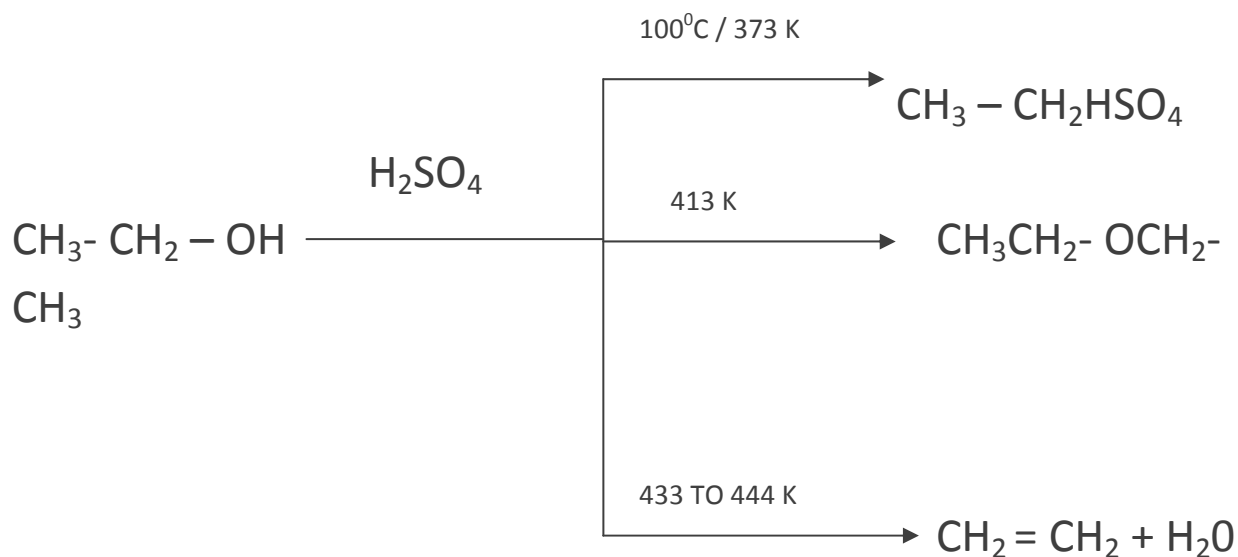

(2) Preparation of phenol from Cumene

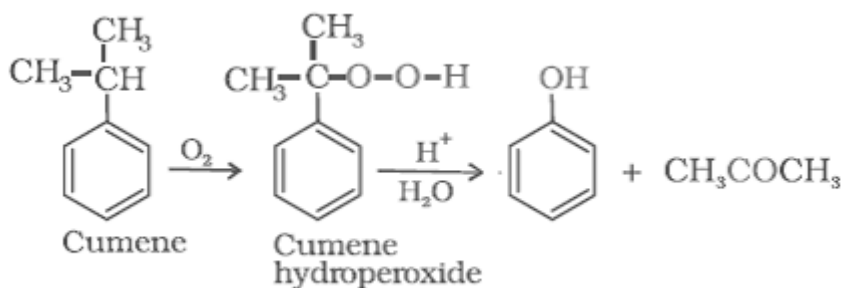

(3) Preparation of aspirin and salol

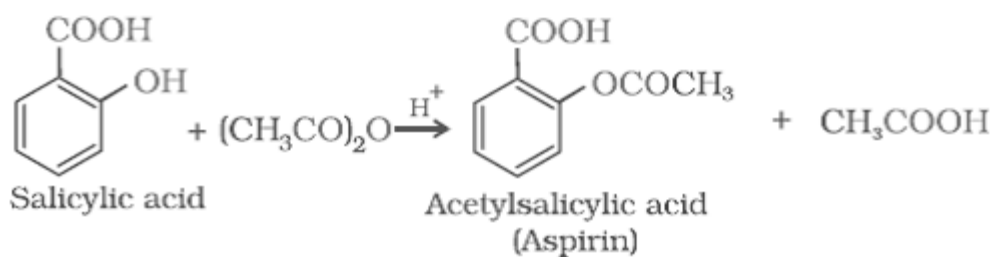

Explain phenol is acidic?

Phenoxide ion is resonance stabilised

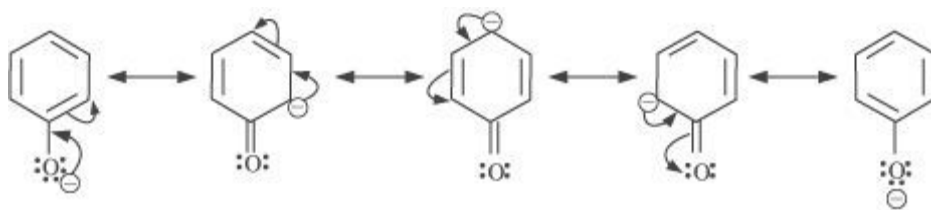

- If electron withdrawing groups are attached to the benzene ring, it enhances acidic character and vice versa.

2,4,6-trinitrophenol > 2,4-dinitrophenol > 4-nitrophenol > phenol

Phenol > m-cresol > p-cresol > o-cresol

m-methoxyphenol > phenol > O methoxy phenol > P methoxy phenol.

O chloro phenol > O bromophenol > O iodo phenol > O fluoro phenol

FORMATION OF PICRIC ACID

(I)

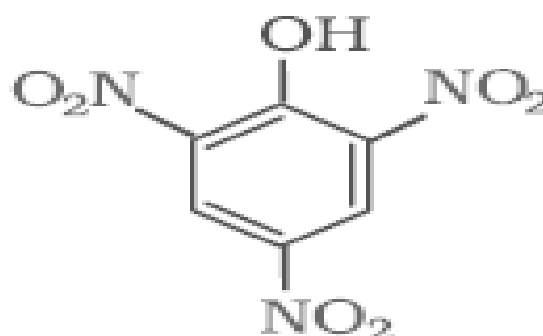
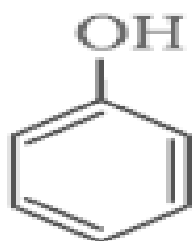

2,4,6-Trinitrophenol
(Picric acid)

+ 3 Br₂

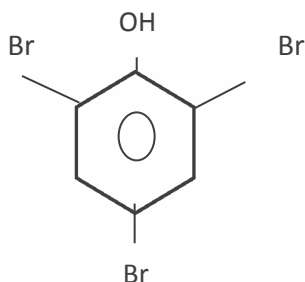

2,4,6 tribromo phenol (white plot)

(I) Phenol gives violet colour with FeCl_3 solution .

PREPARATION OF 1^o, 2^o, 3^o ALCOHOLS

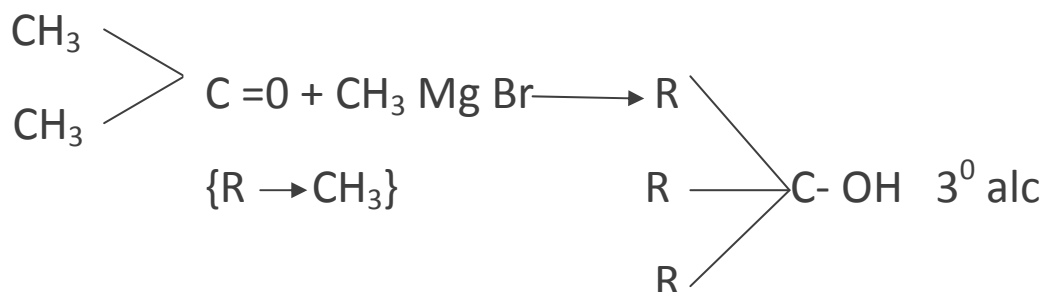
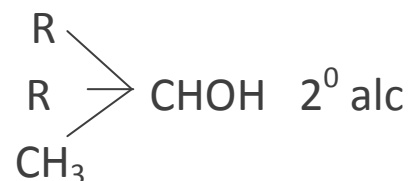
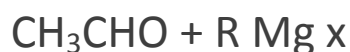
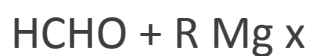

CONCEPTUAL QUESTIONS

Q1) Preparation of ethers by acid dehydration of secondary or 3^o alcohols is not a suitable method?

Ans:- The formation of ethers by dehydration of alcohol is a bimolecular reaction (S_N2) group is hindered. as a result elimination dominates substitution as 3^o carbocation is more stable. Hence in place of ethers, alkenes are formed.

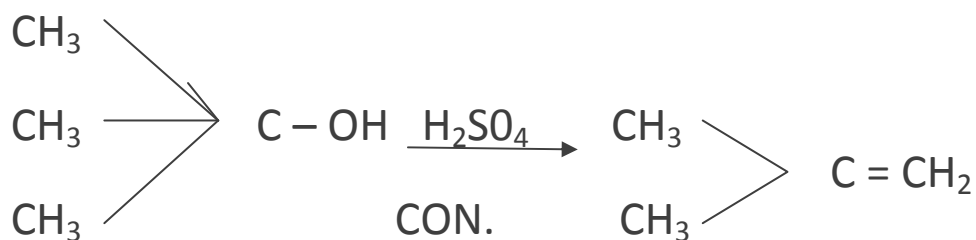

Q2) Phenols do not give protonation reactions readily. Why?

Ans:- The lone pair on oxygen of O-H in phenol is being shared with benzene ring through resonance. Thus, lone pair is not fully present on oxygen and hence phenols do not undergo protonation reactions.

Q3) Ortho- nitrophenol is more acidic than ortho -methoxy phenol ? why?

Ans:- NO_2 group is electron withdrawing which increases acidic character due to ease

REASONING QUESTIONS

Q1. Explain why propanol has higher boiling point than that of the hydrocarbon, butane?

Ans . The molecules of Butane are held together by weak van der Waal's Forces of attraction while those of propanol are held together by stronger intermolecular hydrogen bonding.

Q2. Alcohols are comparatively more soluble in water than hydrocarbons of comparable molecular masses. Explain this fact.

Ans. Alcohols can form hydrogen bonds with water and break the hydrogen bonds already existing between water molecules Therefore they are soluble in water. Whereas hydrocarbons cannot form hydrogen bonds with water and hence are insoluble in water.

Q3 . While separating a mixture of ortho and para nitrophenols by steam distillation, name the isomer which will be steam volatile. Give reason.

ANS. O-nitrophenol is steam volatile due to intramolecular hydrogen bonding and hence can be separated by steam distillation from p-nitrophenol which is not steam volatile because of inter-molecular hydrogen bonding.

Q4. Explain why is ortho nitrophenol more acidic than ortho methoxyphenol?

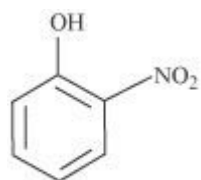

o - Nitrophenol

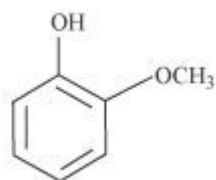

o - Methoxyphenol

ANS. The nitro-group is an electron-withdrawing group. The presence of this group in the ortho position decreases the electron density in the O-H bond. As a result, it is easier to lose a proton. Also, the o-nitrophenoxide ion formed after the loss of proton is stabilized by resonance. Hence, ortho-nitrophenol is stronger acid. On the other hand, methoxy group is an electron-releasing group. Thus, it increases the electron density in the O-H bond and hence, the proton cannot be given out easily. Therefore ortho-nitrophenol is more acidic than ortho-methoxyphenol.

KRISHNA
PUBLIC SCHOOL

Q5. Preparation of ethers by acid dehydration of secondary or tertiary alcohols is not a suitable method. Give reason.

ANS. The formation of ethers by dehydration of alcohol is a bimolecular reaction (S_N)₂ involving the attack of an alcohol molecule on a protonated alcohol molecule. In the method, the alkyl group should be unhindered. In case of secondary or tertiary alcohols, the alkyl group is hindered. As a result, elimination dominates substitution.

Q6. What is meant by hydroboration-oxidation reaction? Illustrate it with an example .

ANS. Diborane (BH₃)₂ reacts with alkenes to give trialkyl boranes as addition product. This is oxidised to alcohol by hydrogen peroxide in the presence of aqueous sodium hydroxide.

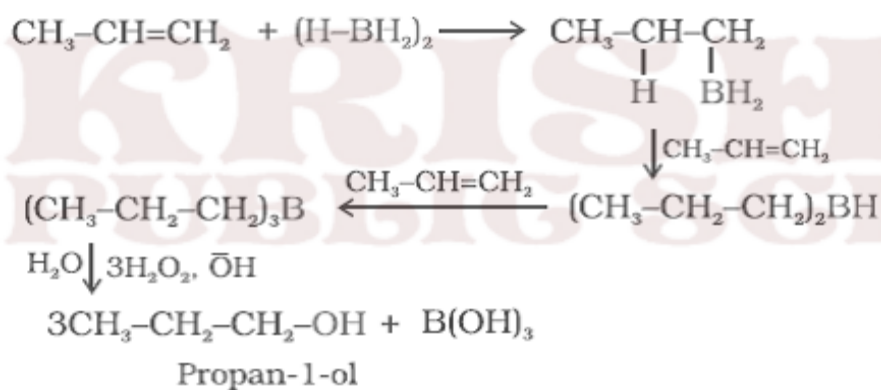

Q7. Give the equations of reactions for the preparation of phenol from cumene.

Ans.

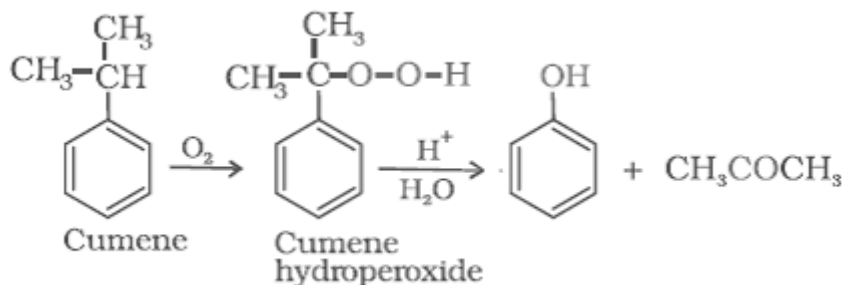

2 MARKS QUESTIONS

Q1. Give two reactions that show the acidic nature of phenol. Compare acidity of phenol with that of ethanol.

ANS. The acidic nature of phenol can be represented by the following two reactions: (i) Phenol reacts with sodium to give sodium phenoxide, liberating H_2 .

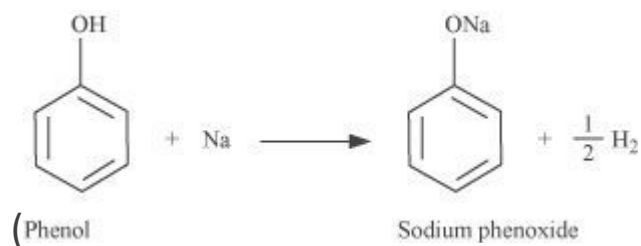

(ii) Phenol reacts with sodium hydroxide to give sodium phenoxide and water as by-products

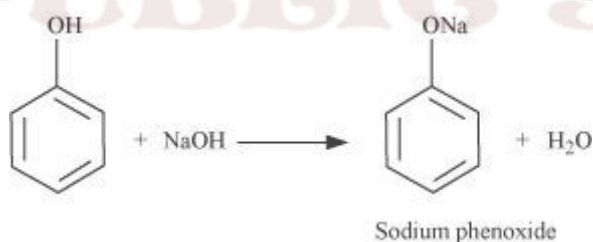

The acidity of phenol is more than that of ethanol. This is because after losing a proton, the phenoxide ion undergoes resonance and gets stabilized whereas ethoxide ion does not.

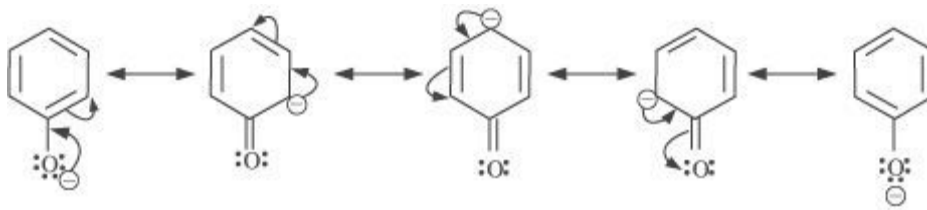

Q2. How does phenol react with dilute and conc. HNO_3 ?

ANS. (i) With dilute nitric acid at low temperature (298 K), phenol yields a mixture of ortho

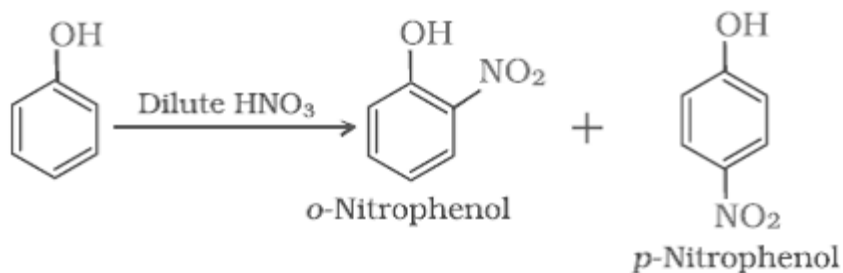

and para nitrophenols. (ii) With concentrated nitric acid, phenol is converted to 2,4,6-trinitrophenol. The product is commonly known as picric acid.

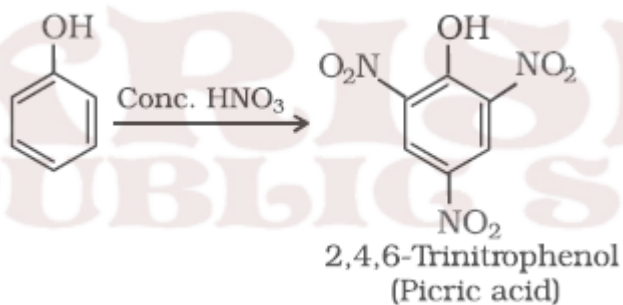

Q3. How does phenol react with Br₂ in CS₂ and Bromine water?

ANS. (i) When the reaction is carried out in solvents of low polarity such as CHCl₃ or CS₂ and at low temperature, monobromophenols are formed.

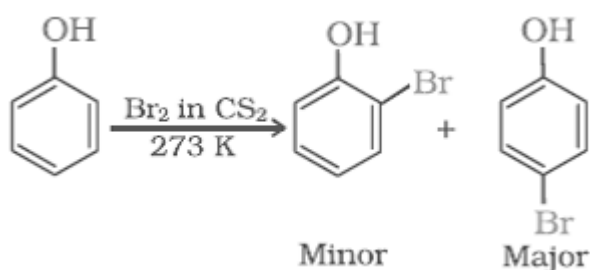

(iii) When phenol is treated with bromine water, 2,4,6-tribromophenol is formed as white precipitate.

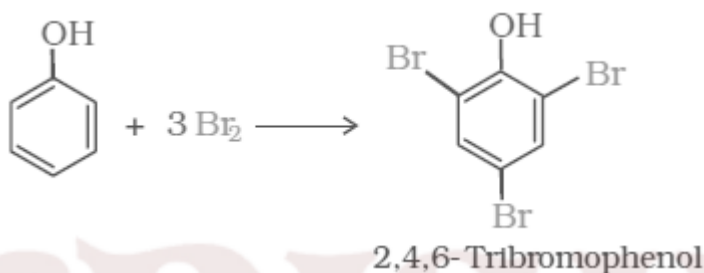

Q4. How do you account for the fact that unlike phenol, 2, 4-dinitrophenol and 2, 4, 6-trinitrophenol are soluble in aqueous solution of sodium carbonate?

ANS. 2, 4-Dinitrophenol and 2, 4, 6-trinitrophenol are stronger acids than carbonic acid (H₂CO₃) due to the presence of electron withdrawing -NO₂ groups. Hence, they react with Na₂CO₃ to form their corresponding salts and dissolve in aq. Na₂CO₃ solution.

Q5 . (i) Why is the Dipole moment of methanol higher than that of phenol? (ii) . Explain why phenols do not undergo substitution of the -OH group like alcohols.

ANS. (i) Due to electron withdrawing effect of phenyl group, the C-O bond in phenol is less polar, whereas in case of methanol the methyl group has electron releasing effect and hence C-O bond in it is more polar.

(ii) C-O bond in phenols has partial double bond character due to resonance and hence is difficult to cleave.

Q6. Account for the following

- a. Boiling point of the C_2H_5OH is more than that of C_2H_5Cl
- b. The solubility of alcohols in water decreases with increase in molecular mass.

ANS. a. Because of hydrogen bonding.

b. With increase in molecular mass the non-polar alkyl group becomes more predominant.

Q7. Answer the following

- a. What is the order of reactivity of 1^o, 2^o and 3^o alcohols with sodium metal?
- b. How will you account for the solubility of lower alcohols in water?

ANS: a. $1^{\circ} > 2^{\circ} > 3^{\circ}$.

b. Here –OH group is predominant and the alcohol molecules can form hydrogen bonds with water molecules.

Q8. Give reasons:

- i) Nitration of phenol gives ortho- and para- products only.
- ii) Why do alcohols have higher boiling points than the haloalkanes of the same molecular mass?

ANS (1) -OH group increases the electron density more at ortho and para positions through its electron releasing resonance effect.

(2) Alcohols are capable of forming intermolecular H-bonds.

Q9. Account for the following:

- i) Phenols has a smaller dipole moment than methanol
- ii) Phenols do not give protonation reactions readily.

ANS. (a). In phenol the electron withdrawing inductive effect of –OH group is opposed by electron releasing the resonance effect of –OH.

(b). The lone pair on oxygen of –OH in phenol is being shared with benzene ring through resonance. Thus, lone pair is not fully present on oxygen and hence phenols do not undergo protonation reactions.

Q10. Explain the fact that in aryl alkyl ethers

(i) The alkoxy group activates the benzene ring towards electrophilic substitution and

(ii) It directs the incoming substituents to ortho and para positions in benzene ring.

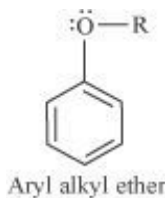

ANS. (i)

In aryl alkyl ethers, due to the +R effect of the alkoxy group, the electron density in the benzene ring increases as shown in the following resonance structure.

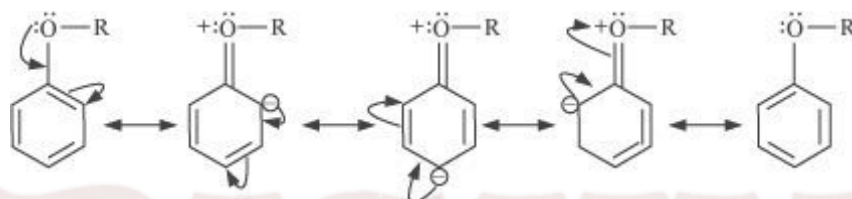

Thus, benzene is activated towards electrophilic substitution by the alkoxy group.

(ii) It can also be observed from the resonance structures that the electron density increases more at the ortho and para positions than at the meta position. As a result, the incoming substituents are directed to the ortho and para positions in the benzene .

3 MARKS QUESTIONS

Q1. How are primary, secondary and tertiary alcohols prepared from Grignard Reagents?

ANS.

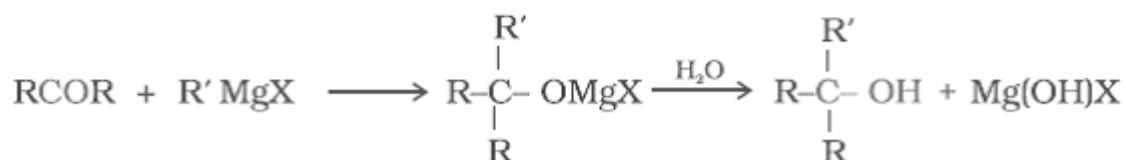
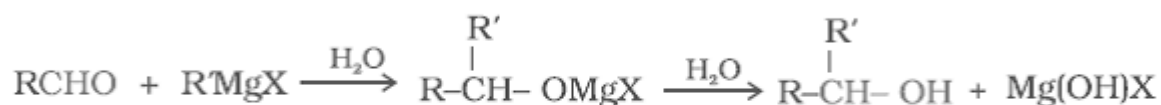
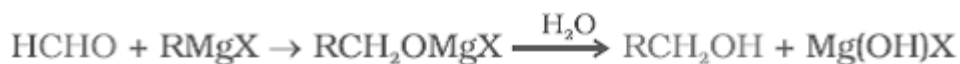

The reaction produces a primary alcohol with methanal, a secondary alcohol with other aldehydes and tertiary alcohol with ketones.

Q2. Give the equations of oxidation of primary, secondary and tertiary alcohols by Cu at 573 K.

ANS.

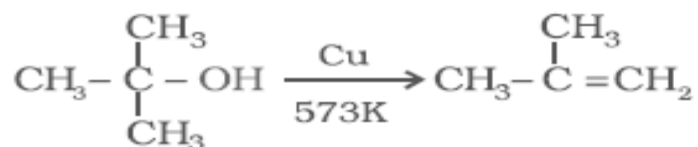
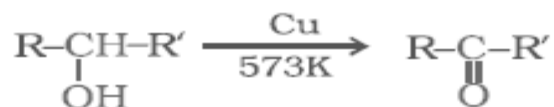
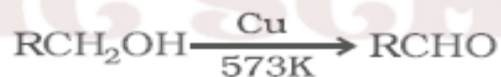

Q4. Show how will you synthesize:

- (i) 1-phenylethanol from a suitable alkene.
- (ii) (ii) cyclohexylmethanol using an alkyl halide by an S_N2 reaction.
- (iii) (iii) pentan-1-ol using a suitable alkyl halide?

ANS. (i) By acid-catalyzed hydration of ethylbenzene (styrene), 1-phenylethanol can be synthesized.

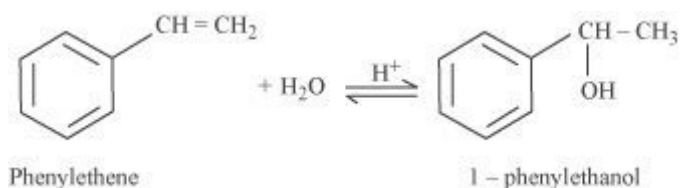

(ii) When chloromethylcyclohexane is treated with sodium hydroxide, cyclohexylmethanol is obtained.

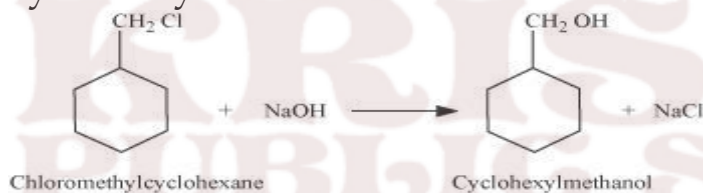

(iv) When 1-chloropentane is treated with NaOH, pentan-1-ol is produced.



Q5. How are the following conversions carried out?

(i) Propene \rightarrow Propan-2-ol

(ii) Benzyl chloride \rightarrow Benzyl alcohol

(iii) Ethyl magnesium chloride \rightarrow Propan-1-ol.

ANS. (i) If propene is allowed to react with water in the presence of an acid as a catalyst, then propan-2-ol is obtained.

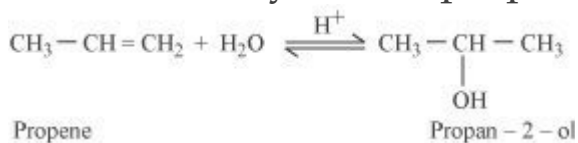

(ii) If benzyl chloride is treated with NaOH (followed by acidification) then benzyl alcohol is produced.

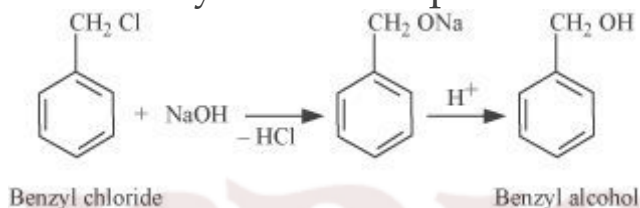

(iii) When ethyl magnesium chloride is treated with methanol, an adduct is produced which gives propan-1-ol on hydrolysis.

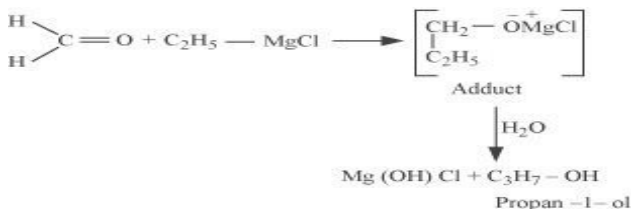

Q6. Name the reagents used in the following reactions:

(i) Oxidation of a primary alcohol to carboxylic acid.

(ii) Oxidation of a primary alcohol to aldehyde.

(iii) Bromination of phenol to 2,4,6-tribromophenol.

ANS. (i) Acidified potassium permanganate

(ii) Pyridinium chlorochromate (PCC)

(iii) Bromine water

Q7. How is 1-propoxypropane synthesised from propan-1-ol? Write mechanism of this reaction.

ANS. 1-propoxypropane can be synthesized from propan-1-ol by dehydration. Propan-1-ol undergoes dehydration in the presence of protic acids (such as H_2SO_4 , H_3PO_4) to give 1-propoxypropane.

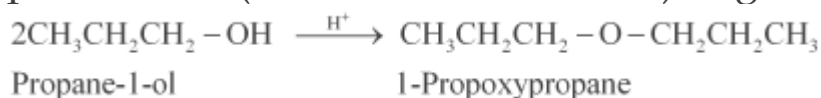

The mechanism of this reaction involves the following three steps:

Step 1: Protonation

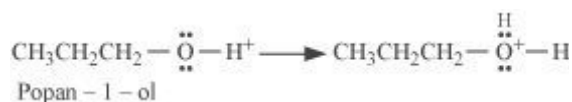

Step 2: Nucleophilic attack

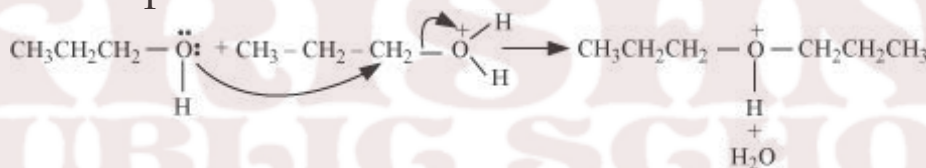

Step 3: Deprotonation

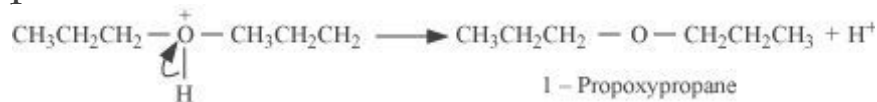

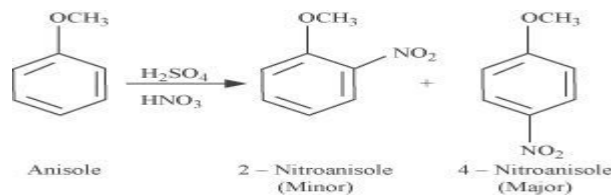

(iii)

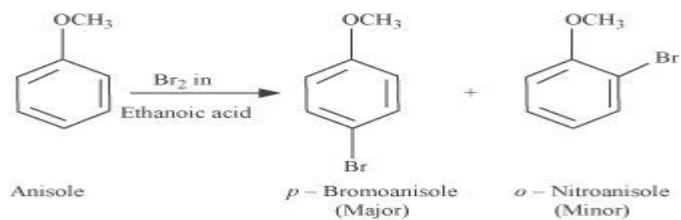

(iv)

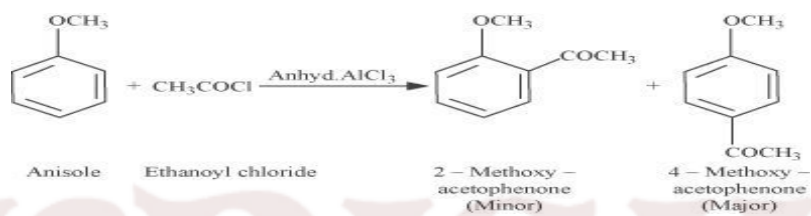

(v)

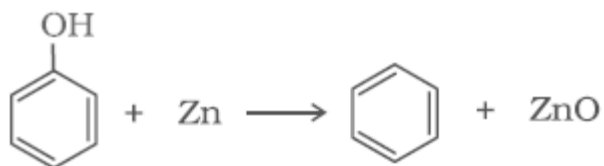

KRISHNA
PUBLIC SCHOOL

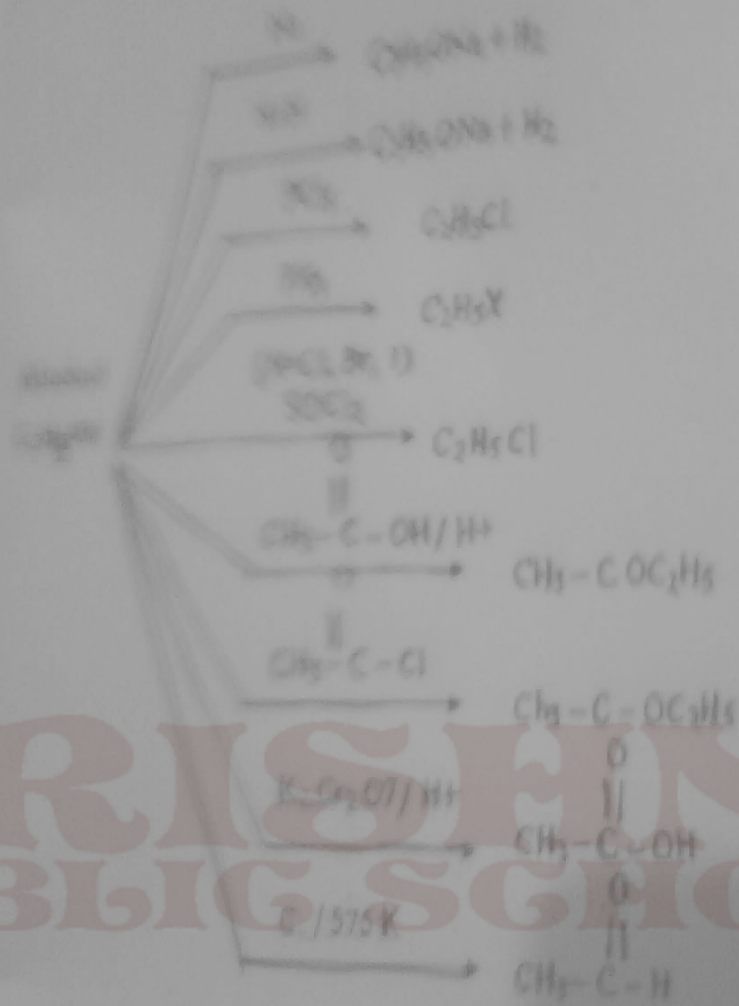

KRISHNA
PUBLIC SCHOOL

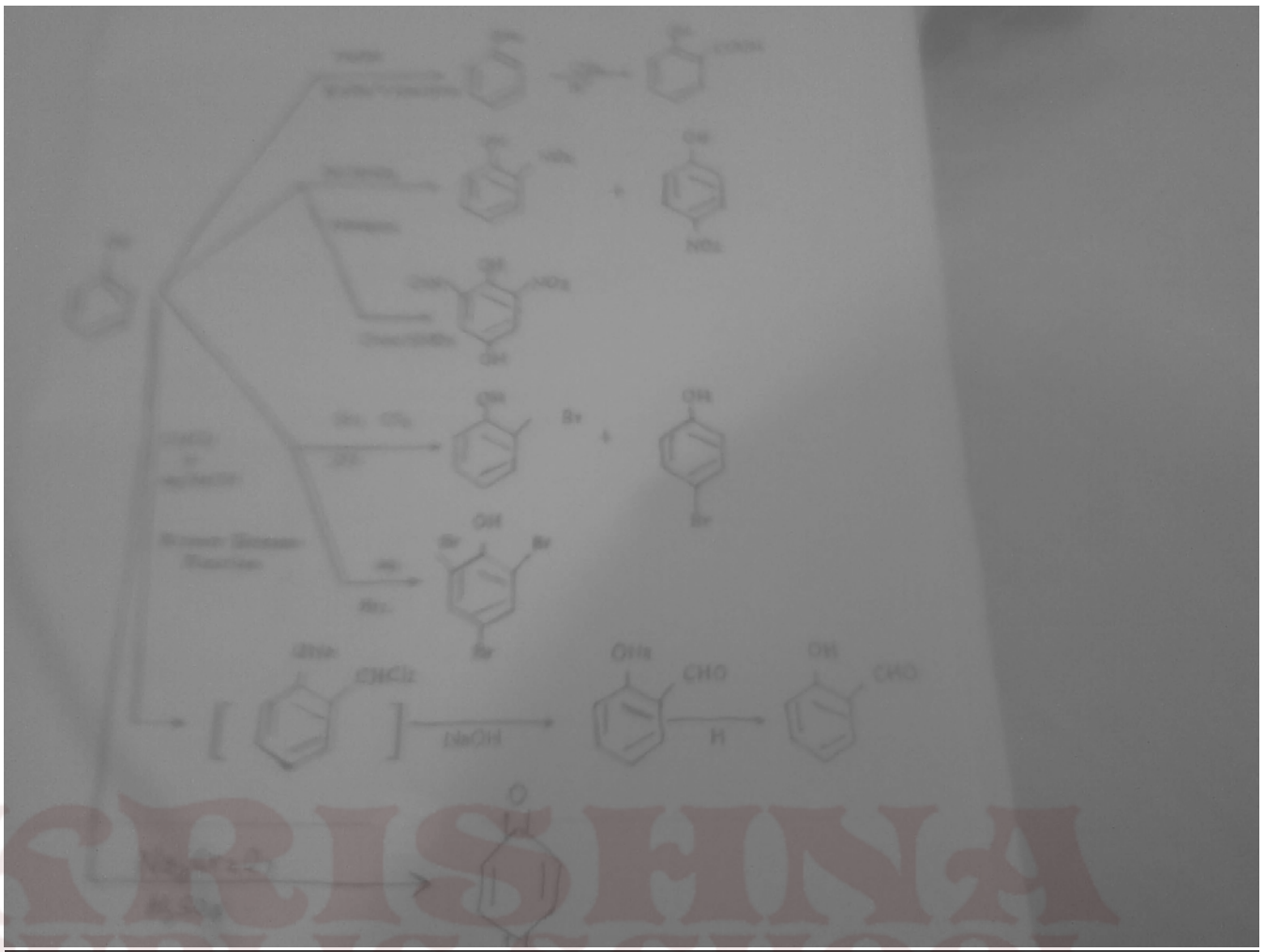

ALDEHYDES, KETONES AND CARBOXYLIC ACIDS

The π Electron cloud of $>C=O$ is unsymmetrical. On the other hand, due to same electronegativity of the two carbon atoms, the π -electron of the $>C=C<$ bond is symmetrical.

Nature of carbonyl group:- The Pi electron cloud of $>C=O$ is unsymmetrical therefore, partial positive charge develop over carbon of carbonyl group while negative charge develop over oxygen of carbonyl group and dipole moment is approximate 2.6D.

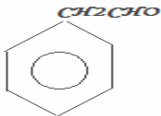
FORMULA	NAME OF THE CORRESPONDING ACID	COMMON NAME	IUPAC NAME
HCHO	HCOOH(formic acid)	Formaldehyde	Methanal
CH ₃ CHO	CH ₃ COOH(Acetic acid)	Acetaldehyde	Ethanal
CH ₃ CH ₂ CHO	CH ₃ CH ₂ COOH(Propanoic acid)	Propionaldehyde	Propanal
CH ₃ CH ₂ CH ₂ CHO	CH ₃ CH ₂ CH ₂ COOH(Butyric acid)	Butyraldehyde	Butanal
CH ₃ CH(CH ₃)CHO	CH ₃ CH(CH ₃)COOH(Isobutyric acid)	Isobutyraldehyde	2-Methylpropanal
CH ₃ CH ₂ CH(CH ₃)CHO	CH ₃ CH ₂ CH(CH ₃)COOH(α -Methylbutyric acid)	α -Methylbutyraldehyde	2-Methylbutanal
CH ₃ CH(CH ₃)CH ₂ CHO	CH ₃ CH(CH ₃)CH ₂ COOH(β -Methylbutyric acid)	β -Methylbutyraldehyde	3-Methylbutanal
			2-Phenylethanal

FORMULA	COMMON NAME	IUPAC NAME
CH ₃ COCH ₃	Dimethyl Ketone or acetone	Propanone
CH ₃ COCH ₂ CH ₃	Ethyl methyl Ketone	Butan-2-one or Butanone
CH ₃ COCH ₂ CH ₂ CH ₃	Methyl n-propyl Ketone	Pentan-2-one
CH ₃ CH ₂ COCH ₂ CH ₃	Diethyl Ketone	Pentan-3-one

Addition to C=O bonds

The structure of the carbonyl group in aldehydes and Ketones is , not entirely adequately represented by >C=O, nor by the alternative >C⁺-O⁻. The real structure or resonance hybrid lies somewhere between the following structure:



For Mechanism

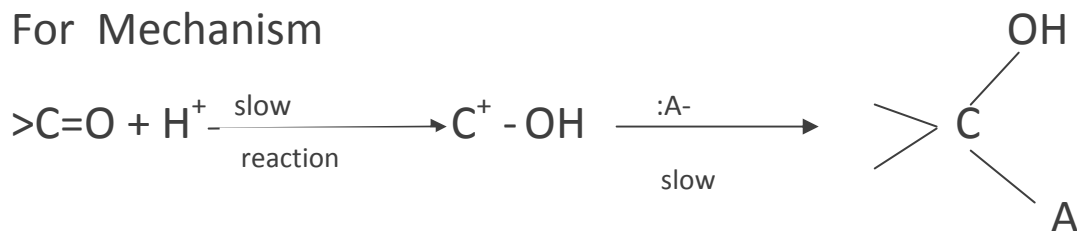

Second Mechanism

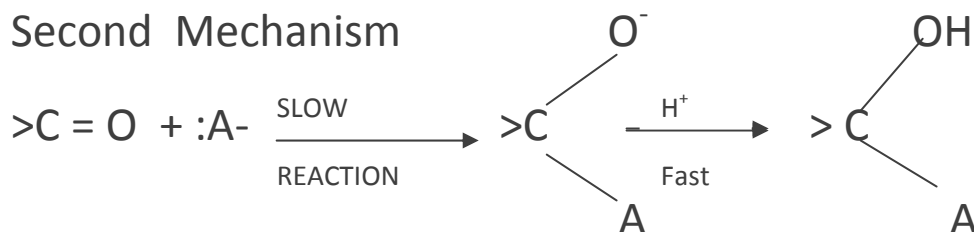

As we know that anion is more stable than the cation, thus the addition to carbonyl groups should take place via mechanism second which has been further proved in the addition of HCN to carbonyl group.

Reactivity of aldehyde and Ketones is as
 $\text{HCHO} > \text{RCHO} > \text{RCOR} > \text{RCOOR} > \text{RCONH}_2$.

POINTS TO REMEMBER

:-Aldehydes, Ketones and Carboxylic acids are important classes of organic compounds containing carbonyl groups.

:-They are highly polar molecules.

:-They boil at higher temperatures than the corresponding hydrocarbons and weakly polar compounds such as ethers.

:-Lower members are soluble in water because they can form H-bond with water.

:-Higher members are insoluble in water due to large size of their hydrophobic group.

:-Aldehydes are prepared by-

- Dehydrogenation of primary alcohols
- Controlled oxidation of primary alcohols.
- Controlled and selective reduction of acyl halides

Aromatic aldehydes can be prepared by-

- Oxidation of toluene with chromyl chloride or CrO_3 in the presence of acetic anhydride
- Formylation of arenes with carbon monoxide and Hydrochloric acid in the presence of anhydrous aluminiumchloride / Cuprous chloride
- Hydrolysis of benzal chloride

Ketones are prepared by-

- oxidation of secondary alcohols
- Hydration of alkenes
- Reaction acyl chlorides with dialkylcadmium
- By friedel crafts reaction

Carboxylic acids are prepared by -

- oxidation of primary alcohols, aldehydes and alkenes
- hydrolysis of nitriles
- Treatment of grignard reagent with carbondioxide.

NAME REACTIONS

ROSENMUND REDUCTION:

Rosenmund Reduction

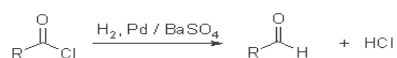

The catalytic hydrogenation of acid chlorides allows the formation of aldehydes.

Mechanism of the Rosenmund Reduction
Side products:

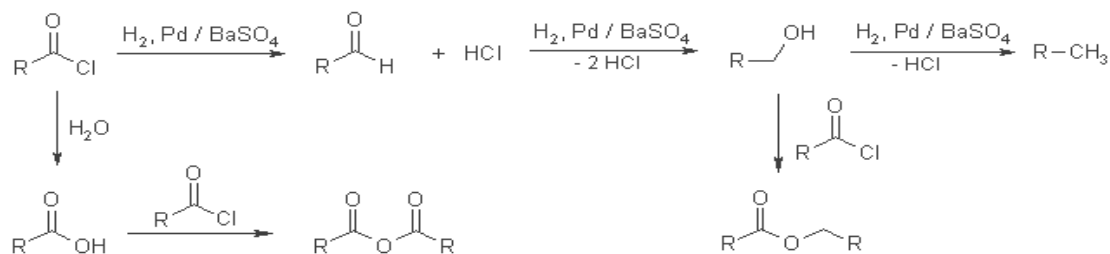

ROSENMUND REDUCTION:

Acyl chlorides when hydrogenated over catalyst, palladium on barium

sulphate yield aldehydes

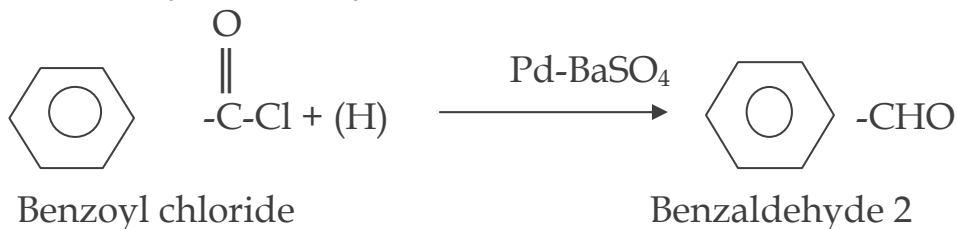

2. STEPHEN REACTION

Nitriles are reduced to corresponding imines with stannous chloride in the presence of Hydrochloric acid, which on hydrolysis give corresponding aldehyde.



ETARD REACTION

On treating toluene with chromyl chloride CrO_2Cl_2 , the methyl group is oxidized to a chromium complex, which on hydrolysis gives corresponding benzaldehyde.

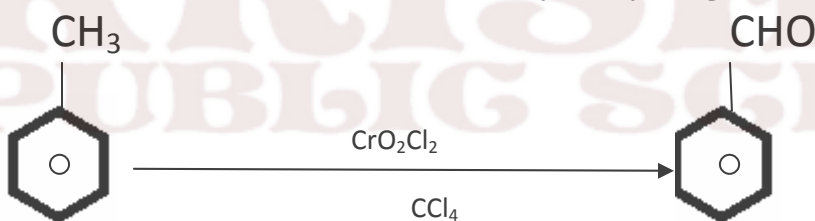

OR

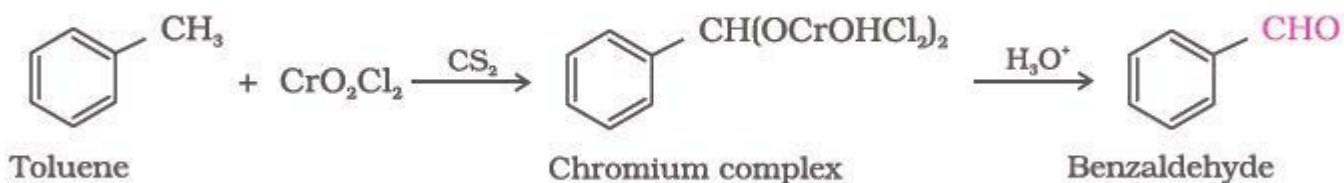

This reaction is called **Etard reaction**.

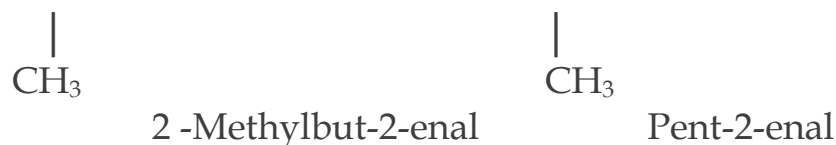

CANNIZARO REACTION

Aldehydes which do not have an α -hydrogen atom, undergo self oxidation and reduction (disproportionation) reaction on treatment with concentrated alkali, to yield carboxylic acid salt and an alcohol respectively.

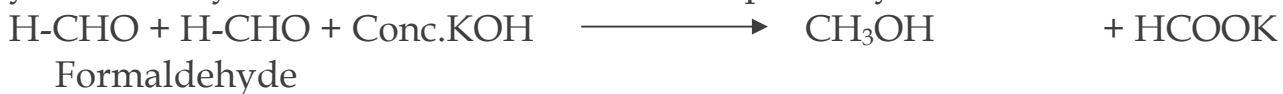

CARBOXYLIC ACID

1. HELL-VOLHARD-ZELINSKY REACTION (HVZ)

Carboxylic acids having an α -hydrogen are halogenated at the α -position on treatment with chlorine or bromine in the presence of small amount of red phosphorus to give α -halocarboxylic acids.

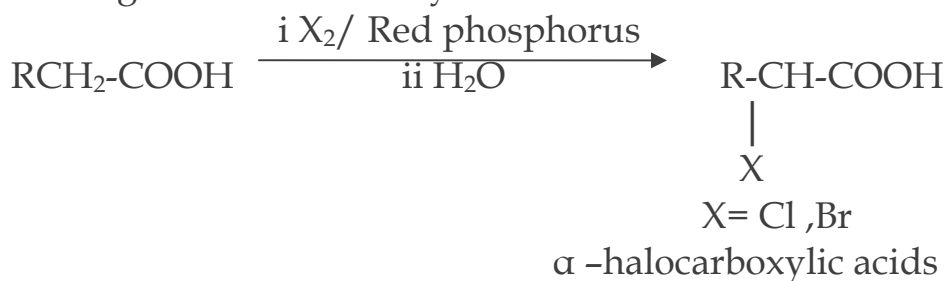

2. ESTERIFICATION

Carboxylic acids react with alcohols or phenols in the presence of a mineral acid such as conc. H_2SO_4 as catalyst to form esters.



NOMENCLATURE

- a. $\text{CH}_3\text{CH}(\text{CH}_3)\text{CH}_2\text{CH}_2\text{CHO}$
4-Methylpentanal
- b. $\text{CH}_3\text{CH}_2\text{COCH}(\text{C}_2\text{H}_5)\text{CH}_2\text{CH}_2\text{Cl}$
6-chloro-4-ethylhexan-3-one
- c. $\text{CH}_3\text{CH}=\text{CHCHO}$
But-2-enal
- d. $\text{CH}_3\text{COCH}_2\text{COCH}_3$
Pentane-2,4-dione
- e. $\text{OHCC}_6\text{H}_4\text{CHO-p}$
Benzene-1,4-dicarbaldehyde
- f. $\text{CH}_3\text{CH}_2\text{CH}(\text{C}_6\text{H}_5)\text{CHO}$
2-Phenylbutanal

2. Draw the structures of the following compounds;

- (i) p-Methylbenzaldehyde



- (ii) 4-Methylpent-3-en-2-one

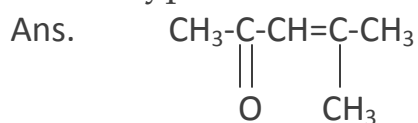

- iii) 3-Bromo-4-phenylpentanoic acid

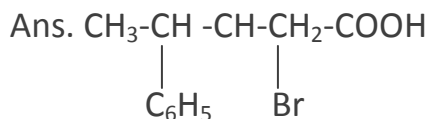

- iv) Hex-2-en-4-ynoic acid



DISTINGUISH

Q1:-Distinguish between the following:-

- (a) Phenol and alcohol
- (b) Benzaldehyde and Propanal
- (c) Acetic acid and formic acid
- (d) Benzophenone and acetophenone
- (e) Ethanal and propanal
- (f) Propanol and ethanol
- (g) Pentanone-2 and pentanone-3
- (h) 2 Alcohol and 3 alcohol
- (i) 1,2,3 amine
- (j) Benzoic acid and benzene
- (k) Phenol and benzoic acid
- (l) Aniline and ethyl amine
- (m) Aniline and nitrobenzene
- (n) Benzaldehyde and acetophenone
- (o) Methanol and benzaldehyde
- (p) Chloro benzene and benzyl chloride

ANSWERS

(a) Phenol
It gives FeCl_3 test
(voilet colour)

Alcohol
It doesn't give this test

(b) Benzaldehyde
It gives tollen's

It doesn't give fehling
solution test

Propanal
It also give tollen's
reagent test
It gives fehling solution
test

(c) Acetic acid
It doesn't gives tollen's reagent
It doesn't give fehling's test

Formic acid
It gives tollen's test
It gives fehling test

(d) Benzophenone
It doesn't give iodoform test

Acetophenone
It gives iodoform test

(e) Ethanal
It gives iodoform test

Propanal
It doesn't gives iodoform
test

(f) Propanol
It doesn't give iodoform test

Ethanol
It gives iodoform test

(g) pentanone-2
It gives iodoform test

pentanone-3
It doesn't gives iodoform
test

(h) 2 alcohol
 $\begin{array}{c} \text{CH}_3 \\ \diagdown \\ \text{CH-OH} \\ \diagup \\ \text{CH}_3 \end{array}$
 \downarrow HCl+ZnCl₂
It takes 5 minutes

3 alcohol
 $\begin{array}{c} \text{CH}_3 \\ \diagdown \\ \text{C-OH} \\ \diagup \\ \text{CH}_3 \\ \diagup \\ \text{CH}_3 \end{array}$
 \downarrow HCl +ZnCl₂
turbidity is formed within no
seconds

CONCEPTUAL QUESTIONS

Q1) Although phenoxide ion has more no. of resonating structures than carboxylate ion, even though carboxylic acid is a stronger acid why?

Ans:- The phenoxide ion has non equivalent resonance structures in which -ve charge is at less electronegative C atom and +ve charge as at more electronegative O-atom.

In carboxylate ion -ve charge is delocalized on two electronegative O-atoms hence resonance is more effective and a stronger acid.

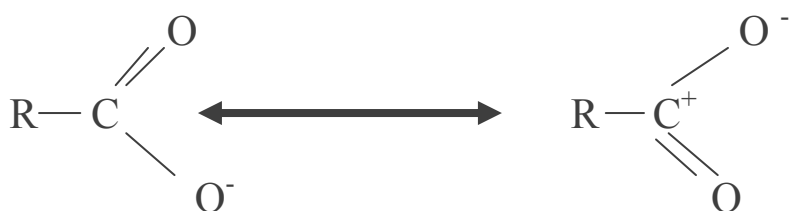

Q.2 Why Carboxylic acid have higher boiling point than alcohols as alcohol forms strongest inter molecular hydrogen bonding?

Ans. As Carboxylic acid forms a dimer due to which their surface area increases and forms strong intermolecular H-bonding

∞ It having more boiling point than alcohols.

Q.3 There are two-NH₂ group in semicarbazide. However only one is involved in formation of semicarbazones. Why?

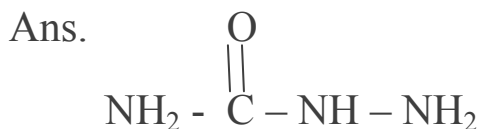

Due to resonance one NH₂ group undergoes or involved in resonance and hence can't participate in the formation of semicarbazone.

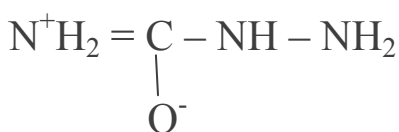

Long pair of NH₂ group is not involved in resonance and is available for nucleophilic attack

Q.4 Why does solubility decreases with increasing molecular mass in carboxytic acid?

Ans. Because of increase in alkyl chain length which is hydrophobic in nature.

Hence solubility decreases.

Q.5 Why are aldehydes are more reactive than ketones when undergo nucleophilic addition reaction?

Ans (a) + I effect:- The alkyl group in Ketones due to their e-releasing character decrease the +ve charge on C-Atom and thus reduce its reactivity.

(b) Steric hinderance:- Due to steric hinderance in ketones they are less reactive.



Q.6 Why PCC cannot oxidise methanol to methanoic acid and while KMNO₄ can?

Ans. This is because PCC is a mild oxidising agent and can oxide methanol to methanal only.

While KMNO₄ being strong oxidising agent oxidises it to methanoic acid.

Q.7 During preparation of esters from a carboxylic acid and an alcohol in the presence of acid catalyst water or ester formed should be removed as soon as it is formed.

Ans. The formation of esters from a carboxylic acid and an alcohol in the presence of acid catalyst in a reversible reaction.



To shift the equilibrium in forward direction, the water or ester formed should be removed as fast as it is formed.

Q.8 Why HCOOH does not give HVZ reaction while CH₃COOH does?

Ans. CH₃COOH contains α-hydrogens and hence give HVZ reaction but HCOOH does not contain α-hydrogen and hence does not give HVZ reaction.

Q.9 Suggest a reason for the large difference in the boiling point of butanol and butanal although they have same solubility in water.

Ans. Because Butanol has strong intermolecular H-bonding while butanal has weak dipole-dipole interaction.

However both of them form H-bonds with water and hence are soluble.

Q.10 Would you expect benzaldehyde to be more reactive or less reactive in nucleophilic addition reaction than propanol. Explain.

Ans. C-atom of Carbonyl group of benzaldehyde is less electrophilic than C-atom of Carbonyl group in propanol.

Polarity of Carbonyl group is in benzaldehyde reduced due to resonance making it less reactive in nucleophilic addition reactions.

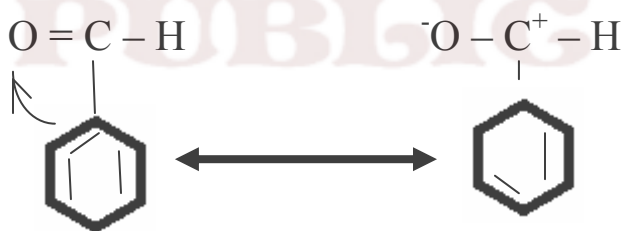

Q.11 Why does methanal not give aldol condensation while ethanol gives?

Ans. This is because only those compounds which have α-hydrogen atoms can undergo aldol reaction ethanol possess α-hydrogen and undergoes aldol condensation Methanal has no alpha hydrogen atoms hence does not undergo aldol condensation.

Q.12 Why does methanal undergo cannizaro's reaction?

Ans. because it does not possess α-hydrogen atom.

Q.13 Which acid is stronger and why?

$\text{F}_3\text{C}-\text{C}_6\text{H}_4\text{COOH}$ and $\text{CH}_3\text{C}_6\text{H}_4\text{COOH}$

Ans . CF_3^- has strong (-I)effect

Whereas, CH_3^- has strong (+I)effect

Due to greater stability of $\text{F}_3\text{CC}_6\text{H}_4\text{COO}^-$ ion over $\text{CH}_3-\text{C}_6\text{H}_4\text{COO}^-$ ion
 $\text{CF}_3\text{C}_6\text{H}_4\text{COOH}$ is much stronger acid than $\text{CH}_3-\text{C}_6\text{H}_4\text{COOH}$.

Q.14 Explain why O-hydroxy benzaldehyde is a liquid at room temperature while p- hydroxy benzaldehyde is a high melting solid.

Ans. Due to intramolecular H-bonding in O-hydroxy benzaldehyde exists as discrete molecule whereas due to intermolecular H-bonding p-hydroxy benzaldehyde exist as associated molecules.

To break this intermolecular H-bonds a large amount of energy is needed. Consequently P-isomer has a much higher m.p. and b.p. than that of O-isomer. As a result O-hydroxy benzaldehyde is liquid.

Q.15 Why is the boiling point of an acid anhydride higher than the acid from which it is derived?

Ans . Acid anhydrides are bigger in size than corresponding acids have more surface area more van der Waals. Force of attraction hence have higher boiling point.

Q.16 Why do Carboxylic acids not give the characteristic reactions of a carbonyl group?

Ans. Due to resonance, It doesn't give the characteristics reactions of carbonyl group. It does not have free

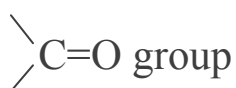

Q.17 Cyclohexanone forms cyanohydrin in good yield but 2,2,6 trimethyl cyclo-hexanone does not. Why?

Ans . In 2,2,6 trimethyl cyclohexanone there is steric hindrance of 3 methyl groups, It does not form cyanohydrin in good yield.

Q.18 Why is carboxyl group in benzoic acid meta directing?

Ans. In benzoic acid the Carboxyl group is meta directing because it is electron-withdrawing

There is +ve charge on ortho and para positions

Electrophilic substitution takes place at meta-position.

Q.19 Treatment of Benzaldehyde with HCN gives a mixture of two isomers which cannot be separated even by careful fractional distillation. Explain why?

Ans. It is because we get two optical isomers which have same physical properties

Cannot be Separated by Fractional distillation.

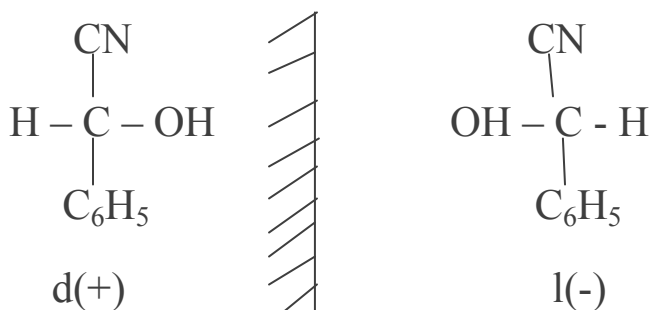

Q.20 Sodium Bisulphite is used for the purification of aldehydes and Ketones. Explain.

Ans. Aldehydes and Ketones form addition compounds with NaHSO_3 whereas impurities do not.

On hydrolysis we get pure aldehydes and Ketones back.

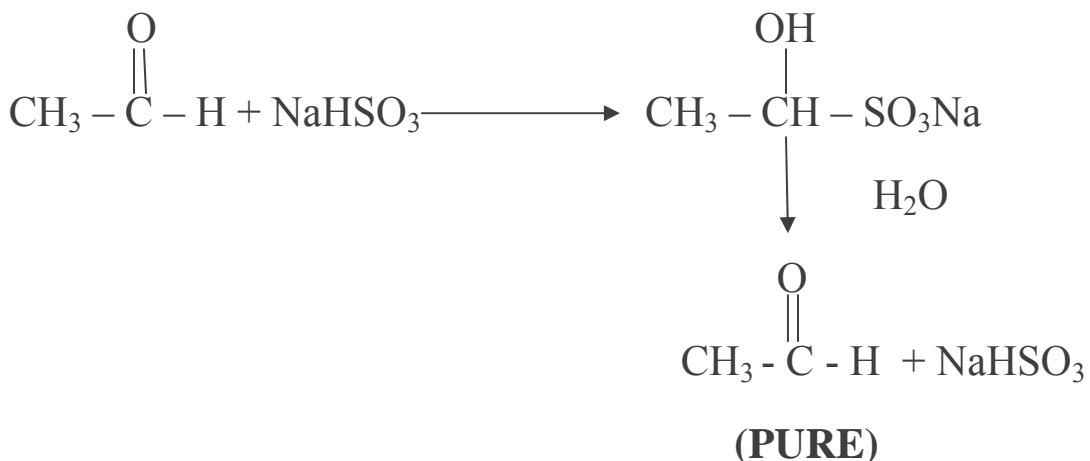

Q.21 Why pH of reaction should be carefully controlled while preparing ammonia derivatives of carbonyl compound?

Ans. In strongly acidic medium ammonia derivatives being basic will react with acids and will not react with carbonyl compound. In basic medium, OH^- will attack carbonyl group.

pH of a reaction should be carefully controlled.

Q.22 Why formic acid is stronger acid than acetic acid?

Ans. Due to +I effect, CH_3^- group in acetic acid increases e^- density on carbon atom which makes it. Weak acid.

While in formic acid no such pushing group is present, hence is more stronger acid than acetic acid.

Q.23 Why is oxidation of alcohals to get aldehydes carried out under controlled conditions?

Ans . It is because aldehydes get further oxidised to acids, oxidation of alcohals to aldehydes needs to be controlled.

Q.24 Why the oxidation of toluene to benzaldehyde with CrO₃ is carried out in the presence of acetic anhydride.

Ans. If acetic anhydride is not used we will get benzoic acid.

Acetic anhydride used to prevent oxidation of benzaldehyde to benzoic acid.

Q.25 Melting point of an acid with even no. of carbon atoms is higher than those of its neighbour with odd no. of carbon atoms.

Ans . They fit into crystal lattice more readily than odd ones that is why they have higher lattice energy and higher melting point.

Q.26 Why do aldehydes have lower boiling point than corresponding alcohals?

Ans. alcohals have lower boiling point as they are not associated with intermolecular whereas alcohals are associated with intermoleculer H-bonding

Aldehydes have lower B.p.

Q.27 Why do aldehydes behave like polar compounds?

Ans. Due to presence of >C=O group which is polar

Q.28 Most aromatic acids are solids while acetic acid and others of this series are liquids. Explain why?

Ans. Aromatic acids have higher molecular weight,

More van-der waals force of attraction as compared to aliphatic acids They are solids.

Q.29 ethers possess a dipole moment even if the alkyl radicals in the molecule are identical. Why?

Ans. It is because ethers are bent molecules, dipole do not get cancelled.

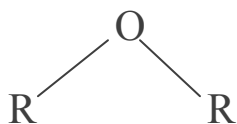

Q.30 Why does acyl chlorides have lower boiling point than corresponding acids?

Ans. Acyl chlorides are not associated with intermolecular H-bonding

They have lower boiling point.

Q.31 Why ethers are stored in coloured bottles?

Ans. They are stored in coloured bottles. In presence of sunlight they react with oxygen to form peroxides which may cause explosion.

Q.32 Why formaldehyde cannot be prepared by Rosenmund's reduction?

Ans. Because the formyl chloride thus formed is unstable at room temperature.

Cannot be prepared by Rosenmund reduction.

-Q1. An organic compound (A) $\{C_8H_{16}O_2\}$ was hydrolysed with dilute sulphuric acid to give a carboxylic acid (B) and an alcohol (C). Oxidation of (C) with chromic acid produced (B). (C) on dehydration gives but-1-ene. Identity A, B, C

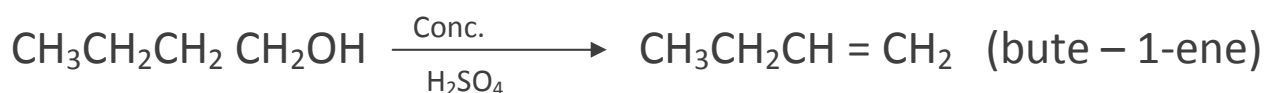
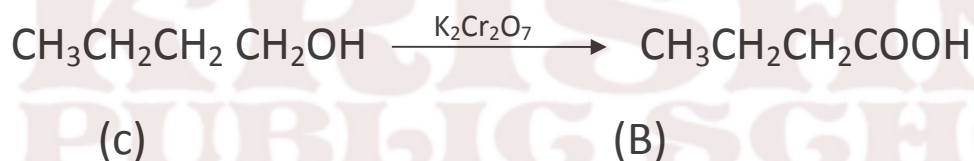
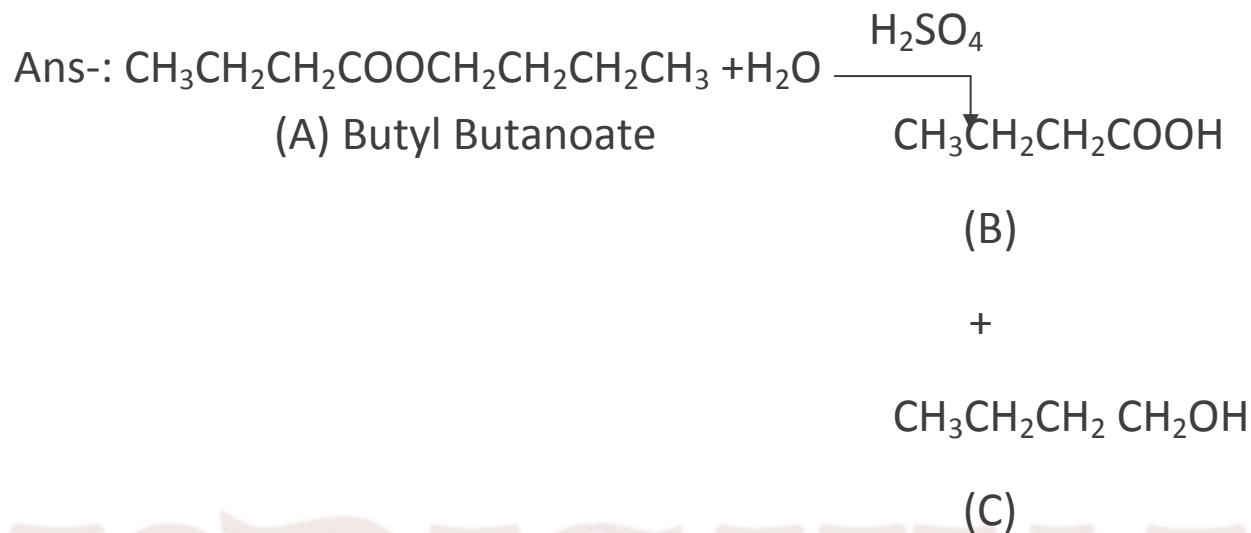

Q2 -: An organic compound with the molecular formula $C_9H_{10}O$ forms 2,4 DNP derivative reduces tollens reagent and undergoes cannizaro reaction . on vigorous oxidation ,it gives 1,2 benzenecarboxylic acid . identify the compound .

Ans:-

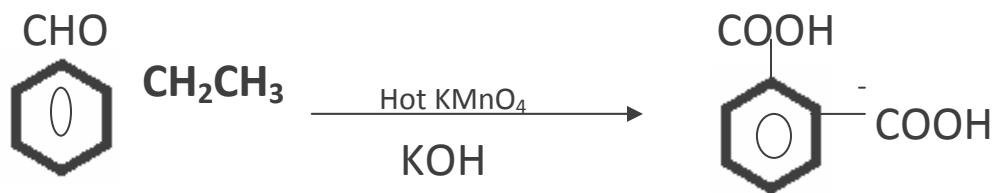
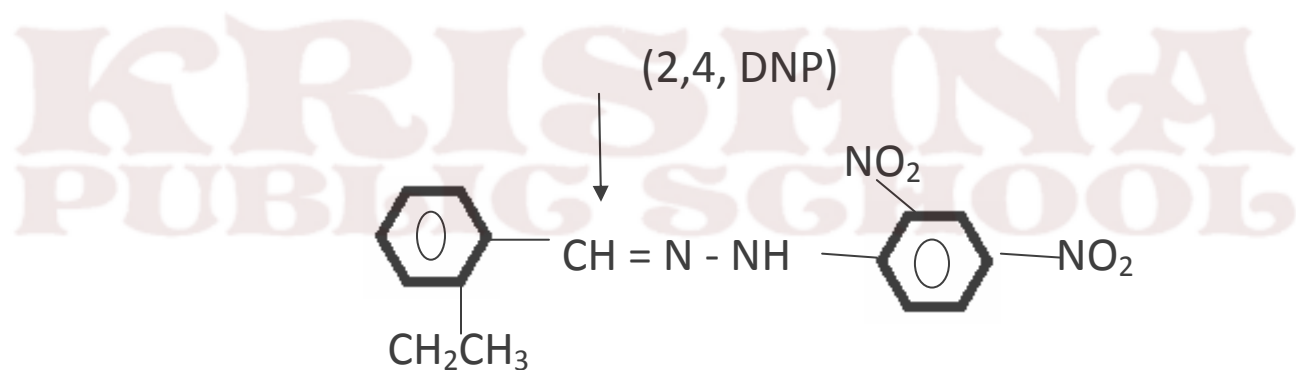
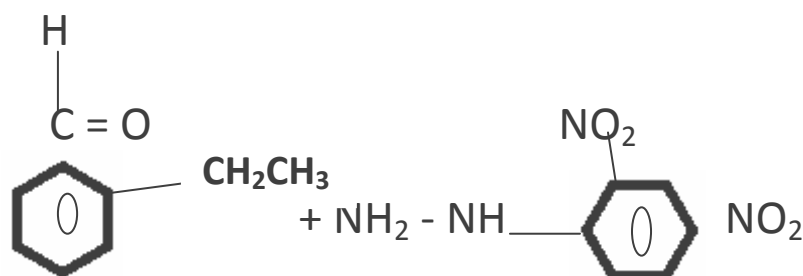

Q3. An organic compound (A) with molecular formula C_8H_8O forms an orange-red precipitate with 2,4 DNP reagent and gives yellow precipitate on heating with iodine in the presence of sodium hydroxide. It neither reduces tollen's or fetiling's reagent , nor does it decolourise bromine water or baeyer's reagents .On drastic oxidation with chromic acid .it gives a carboxylic acid (B) having molecular formula $C_7H_6O_2$. Identify the compounds (A) and (B).

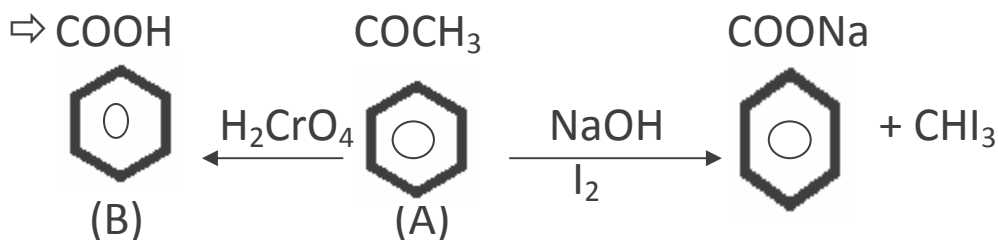
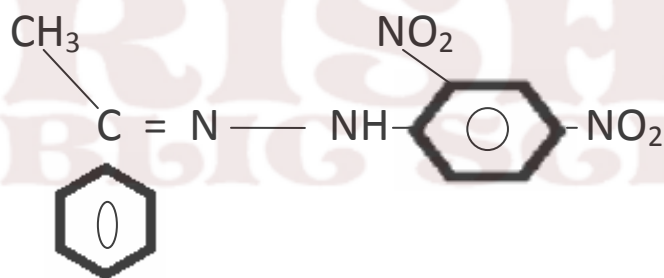
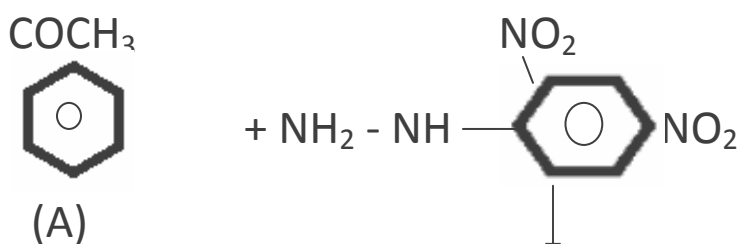

Q4. Two moles of organic compound A on treatment with a strong base gives two compounds B and C. Compound B on dehydration with Cu gives A while acidification of C yields carboxylic acid D having molecular formula of CH₂O₂. Identify the compounds A, B, C, D

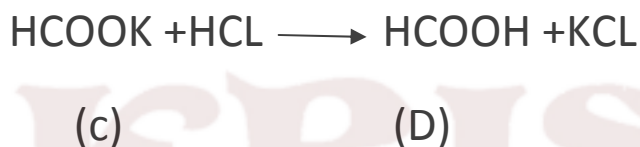
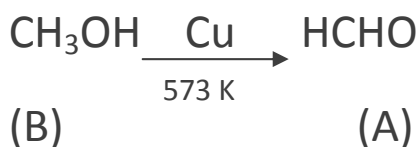
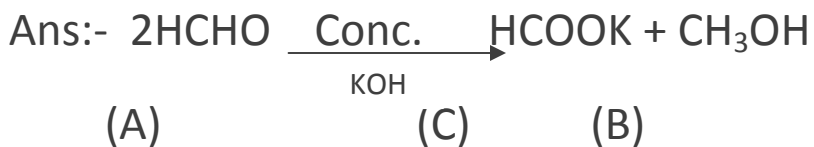

Q5. An aliphatic compound [A] with a molecular formula of C₃H₆O reacts with phenylhydrazine to give compound [B]. Reaction of [A] with I₂ in alkaline medium on warming gives a yellow precipitate [C]. Identify the component A, B, C

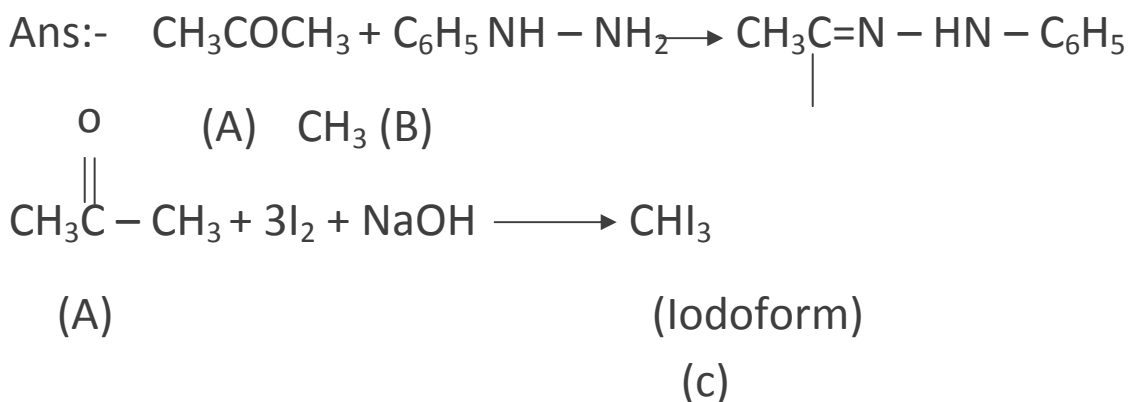

Q7 An organic compound 'A' has the molecular formula $C_5H_{10}O$. It does not reduce Fehling's solution but forms a bisulphite compound. It also gives positive Iodoform test. What are possible structures of 'A'? Explain your reasoning.

Ans:- It does not reduce Fehling's solution but forms bisulphite compound so it is a ketone therefore it gives positive Iodoform test therefore it is methyl ketone.

The possible structures are:-

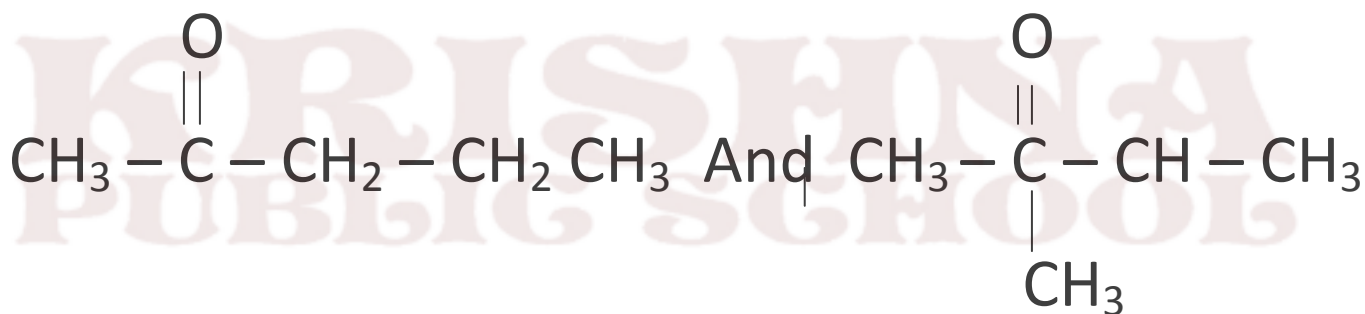

Q8. An organic compound 'A' which has characteristic odour, on treatment with NaOH forms two compounds 'B' and 'C'. Compound 'B' has the molecular formula C_7H_8O which on oxidation gives back compound 'A'. Compound 'C' is the sodium salt of an acid which when heated with soda lime yields an aromatic hydrocarbon 'D'. Deduce A,B,C,D

Ans.

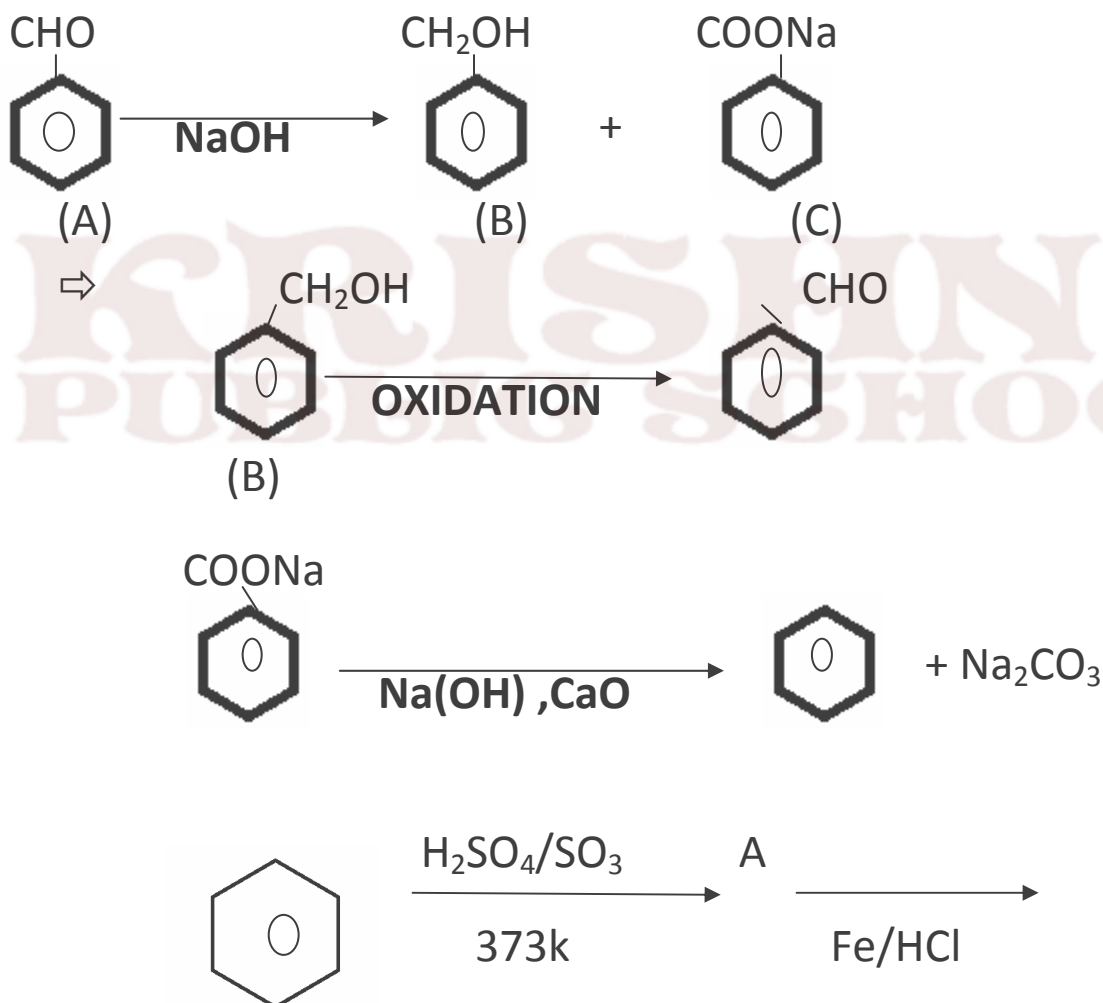

Q9. An organic compound 'A' is resistant to oxidation forms an oxidation forms a compound 'B' (C₃H₈O) on reduction. 'B' reacts with HBr to form a bromide 'C' which on treatment with alcoholic KOH forms an alkene 'D' (C₃H₆). Deduce A,B,C,D.

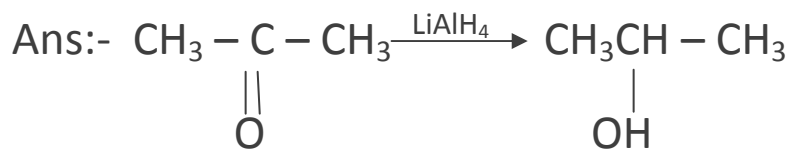

(A)

(B)

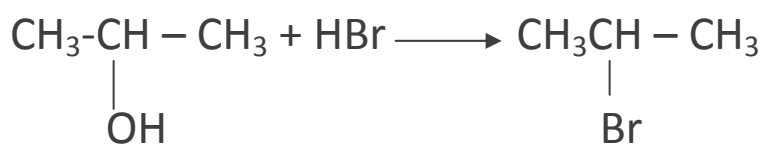

(B)

(C)



(D)

Q10. Aerial solution of an organic compound 'A' when heated with magnesium gave 'B' on treatment with ethanal followed by acid hydrolysis gave 2-propanol. Identify the compound 'A'. What is 'B' known as?



(a)

(b)



Q12. Primary alkyl halide C_4H_9Br (A) reacted with alcoholic KOH to give compound (B) which is reacted with HBr to give (C) which is an isomer of (A). When (A) is reacted with sodium metal it gives compound (D) C_8H_{18} that was different from the compound formed when n-butyl bromide is reacted with sodium. Give the formula of (A) and write equations.

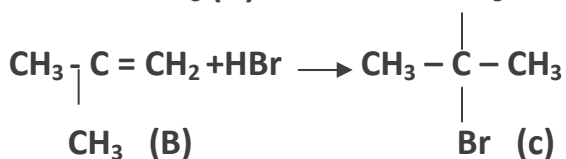
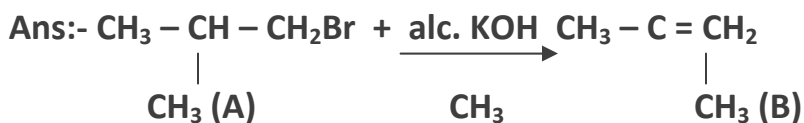

C is the isomer of A

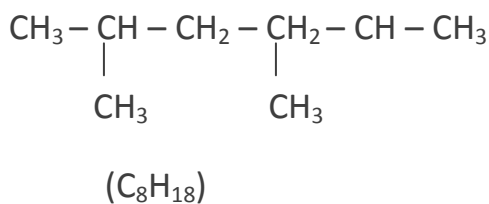
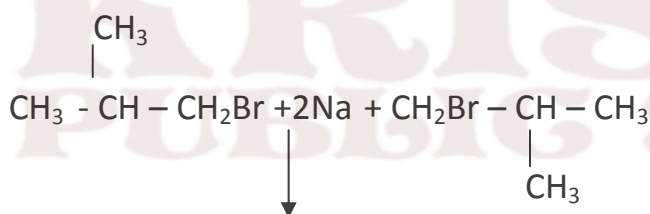

Q13 . An organic compound 'A' having molecular formula C_4H_8 on treatment with dil. H_2SO_4 gives 'B'. 'B' on treatment with conc. HCl and anhydrous $ZnCl_2$ gives C and on treatment with sodium ethoxide gives back A. Identify A, B, C.

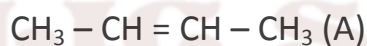
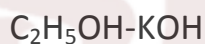
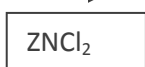
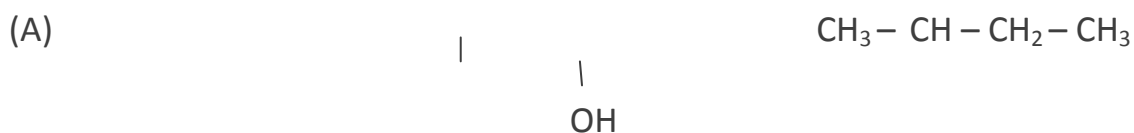
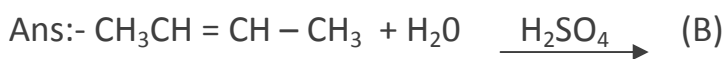

Q14. An aromatic compound A on treatment with aqueous ammonia and heating forms compound B which on heating with Br_2 and KOH forms a compound C of molecular formula C_6H_7N . Identify A, B, C.

Ans:-

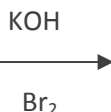
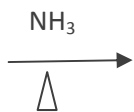

(Benzoic acid)

(Benzamide)

(Aniline)

Q15 . Two isomeric compound A and B having molecular formula $C_{15}H_{11}N$, both lose N_2 on treatment with HNO_2 and gives compound C and D. C is resistant to oxidation but immediately responds to oxidation to lucas reagent after 5 minutes and gives a positive Iodoform test. Identify A and B .

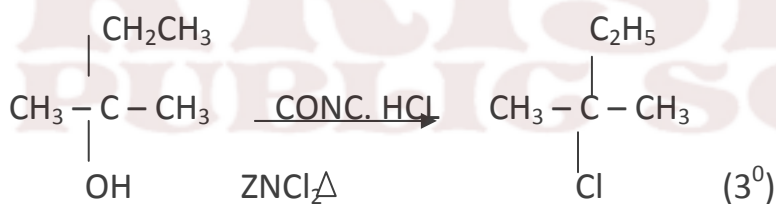
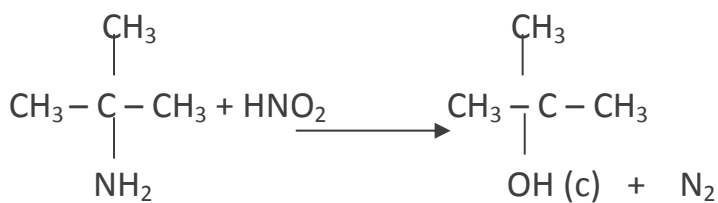
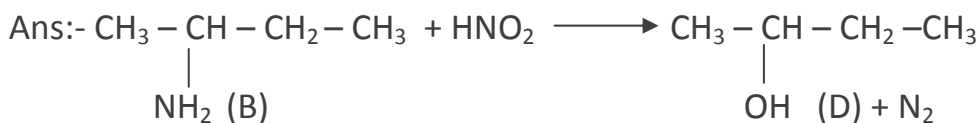

©

But 'D' respond to lucas reagent in 5 minutes.

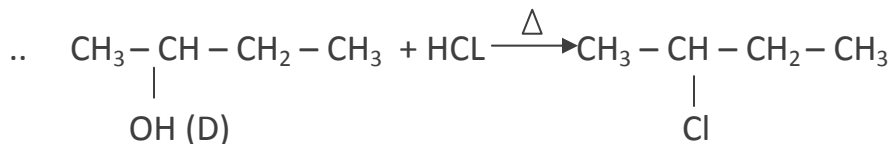

Q16. An organic compound 'A' having molecular formula $C_2H_5O_2N$ reacts with HNO_2 and gives $C_2H_4O_3N_2$. On reduction 'A' gives a compound 'B' with molecular formula C_2H_7N . 'C' on treatment with HNO_2 gives 'C' which gives positive iodoform test. Identify A, B, C.

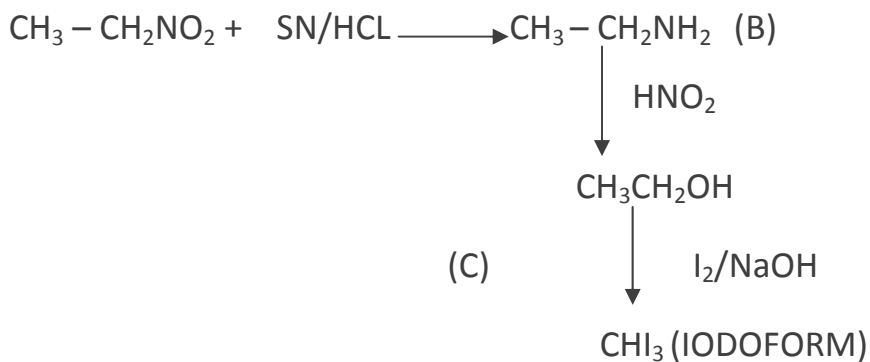
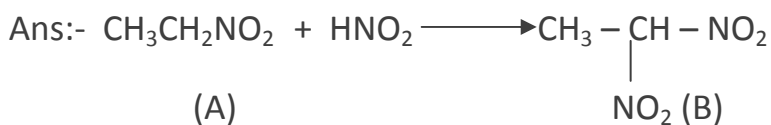

Q17. An organic compound 'A' having molecular formula C_3H_5N on reduction gave another compound 'B'. The compound B on treatment with HNO_2 gave propyl alcohol. B on warming with $CHCl_3$ and alcoholic caustic potash give the offensive smelling C. Identify A, B, C

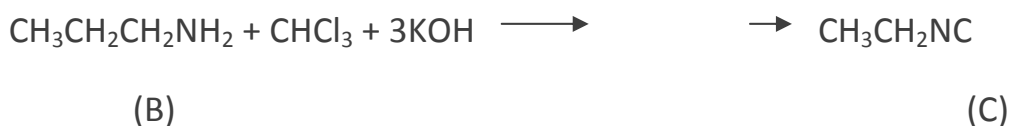
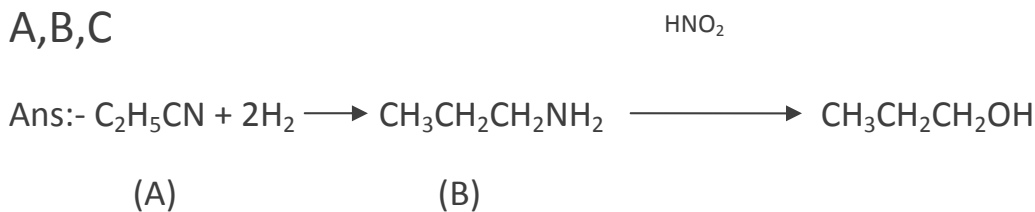

Q18 . Iodomethane reacts with KCN to form a major product A .Compound 'A' on reduction in presence of LiAlH_4 forms a higher amine 'B'. Compound B on treatment with CuCl_2 forms a blue colour complex C . Identify A,B,C

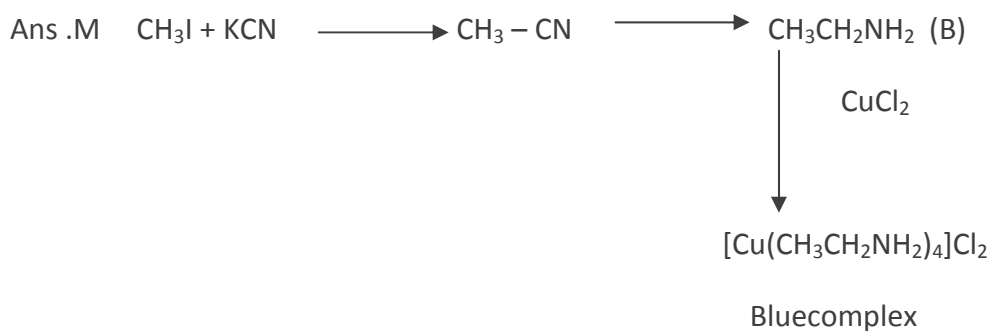

Q19. An aliphatic compound A with molecular formula $\text{C}_2\text{H}_3\text{Cl}$ on treatment with AgCN gives two isomeric compounds of unequal amount with the molecular formula $\text{C}_3\text{H}_3\text{N}$.The minor of these two products on complete reduction with H_2 in the presence of Ni gives a compound 'B' with molecular formula $\text{C}_3\text{H}_9\text{N}$. Identify the compounds.

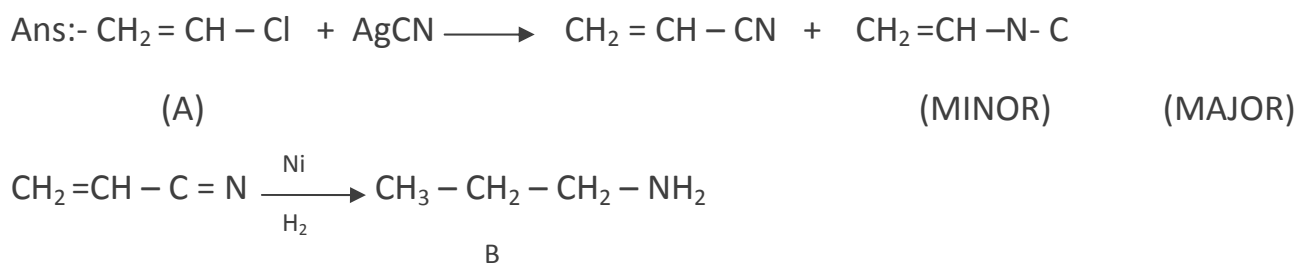

Q20. A compound 'X' having molecular formula C_3H_7NO reacts with Br_2 in presence of KOH to give another compound Y. the compound Y reacts with HNO_2 to form ethanol N_2 gas. Identify X,Y,

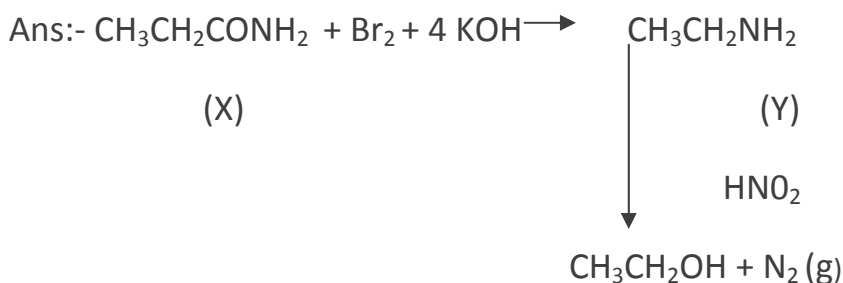

Q21. A compound 'A' of molecular formula $C_3H_7O_2N$ reaction with Fe and conc, HCl gives a compound 'B' OF molecular formula C_3H_9N . Compound 'B' on treatment with $NaNO_2$ and HCl gives another compound 'C' of molecular formula C_3H_8O .The compound 'C' gives effervescences with Na on oxidation with CrO_3 .The compound 'C' gives a saturated aldehyde containing three carbon atom deduce A,B,C.

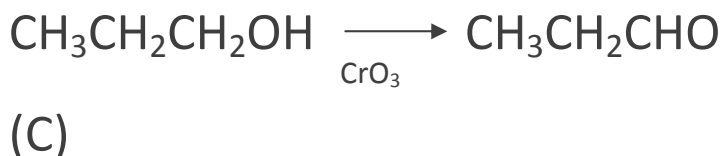
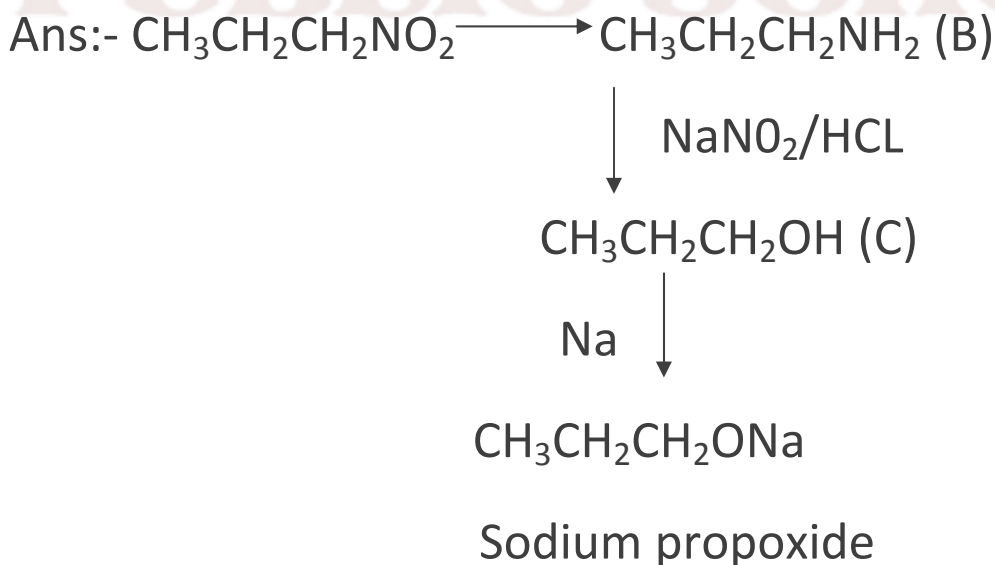

Q22. A Chloro compound [A] on reduction with Zn – Cu and alcohol gives the hydro carbon (B) with five carbon atom. When [A] is dissolved in ether and treated with sodium 2,2,5,5 tetramethyl hexane is formed structure of A and B?

Ans. CH₃

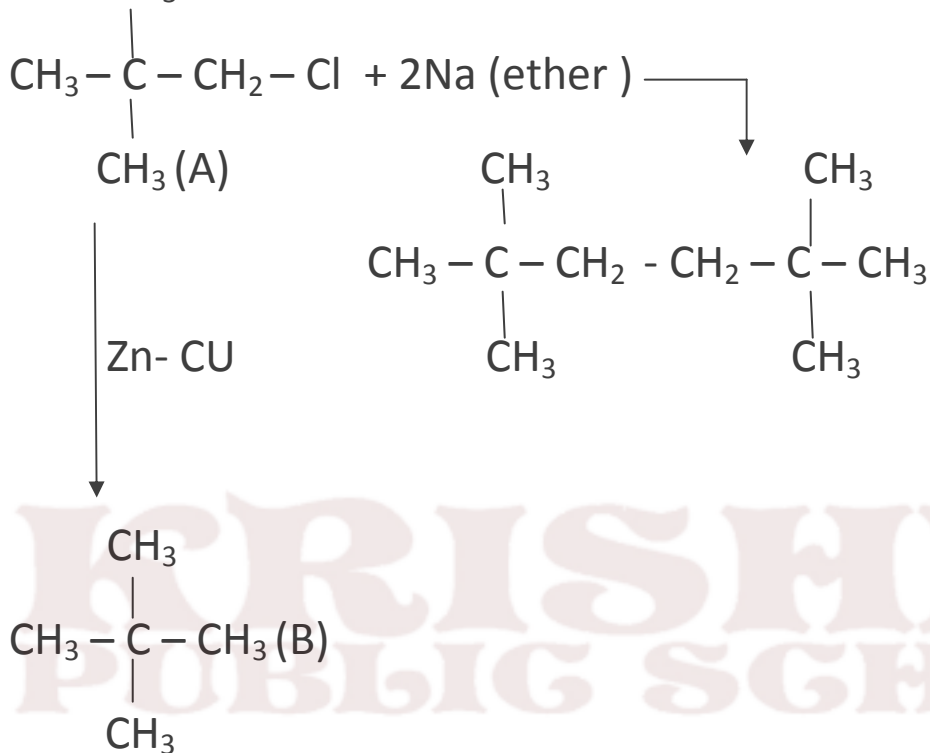

IDENTIFY A,B,C

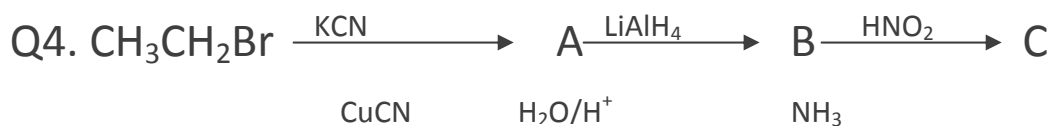
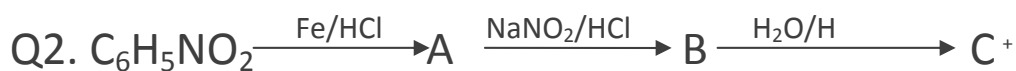
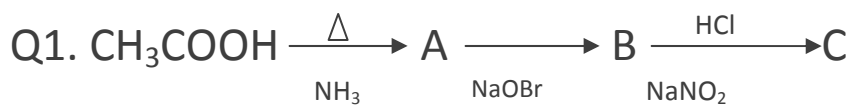

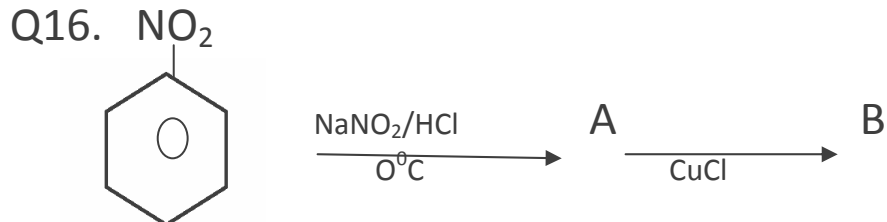
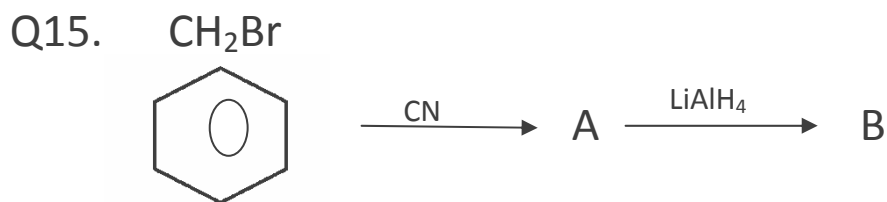
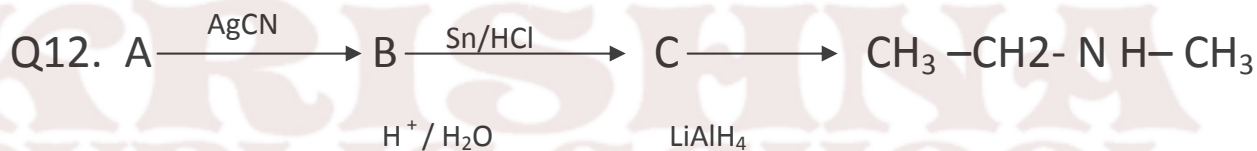
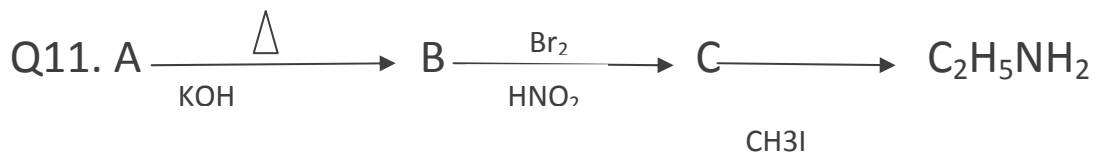
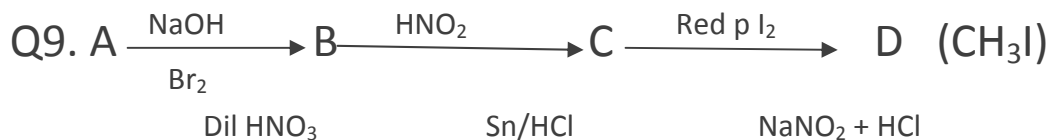
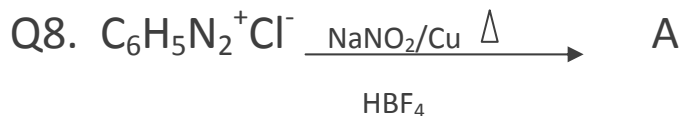
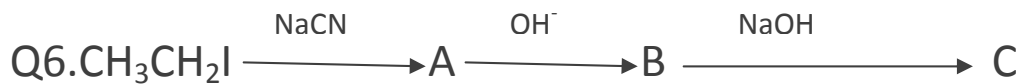

Q17. NO_2

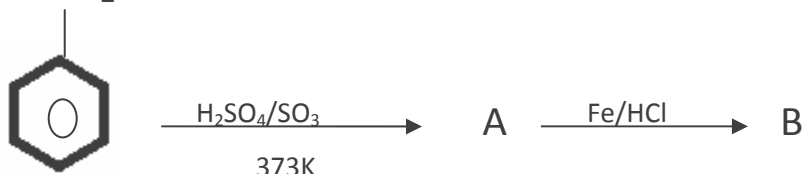

ANSWERS

1. A = CH_3CONH_2 , B = CH_3NH_2 , C = CH_3OH

2. A = $\text{C}_6\text{H}_5\text{NH}_2$, B = $\text{C}_6\text{H}_5\text{N}_2^+\text{Cl}^-$, C = 

3. A = $\text{CH}_3\text{CH}_2\text{CN}$, B = $\text{CH}_3\text{CH}_2\text{-CH}_2\text{NH}_2$, C = $\text{CH}_3\text{CH}_2\text{CH}_2\text{OH}$

4. A = $\text{C}_6\text{H}_5\text{NH}_2$, B = $\text{C}_6\text{H}_5\text{N}_2^+\text{Cl}^-$, C = $\text{CH}_3\text{CH}_2\text{CH}_2\text{OH}$

5. A = $\text{C}_6\text{H}_5\text{CN}$, B = $\text{C}_6\text{H}_5\text{COOH}$, C = $\text{C}_6\text{H}_5\text{CONH}_2$

6. A = $\text{CH}_3\text{CH}_2\text{CN}$, B = $\text{CH}_3\text{CH}_2\text{CONH}_2$, C = $\text{CH}_2\text{CH}_2\text{NH}_2$

7. A) NHCOCH_3

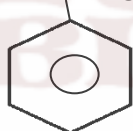

+ CH_3COOH

8. $\text{C}_6\text{H}_5\text{NO}_2 = \text{A}$

9. A = CH_3CONH_2 , B = CH_3NH_2 , C = CH_3OH

10. A) OH , B) OH , C) OH

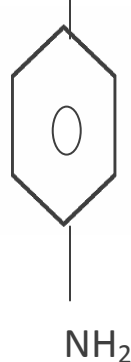
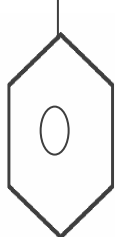

11. A = $\text{CH}_3\text{CH}_2\text{COONH}_4$, B = $\text{CH}_3\text{CH}_2\text{CONH}_2$, C = $\text{CH}_3\text{CH}_2\text{NH}_2$

12. A = CH_3Cl , B = CH_3NC , C = $\text{CH}_3\text{-CH}_2\text{-NH-CH}_3$

13. A = CH_3COOH , B = $\text{CH}_3\text{CH}_2\text{OH}$

14. A = $\text{R}-\underset{\text{R}}{\text{C}}=\text{NH}$, B = $\text{R}-\underset{\text{R}}{\text{CH}}-\text{NH}_2$

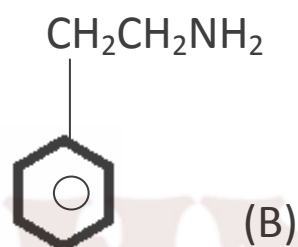
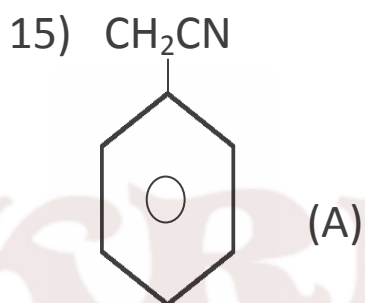

16)

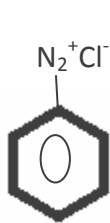

17) A =

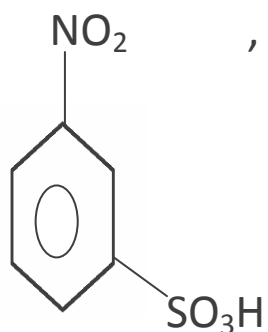

, B =

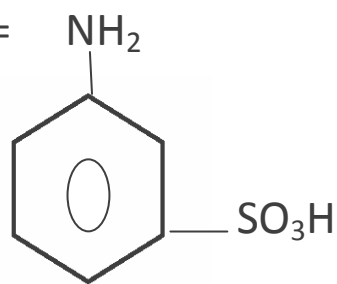

1 MARK QUESTIONS

Q1. Name the reaction and the reagent used for the conversion of acid chlorides to the corresponding aldehydes.

A. Name : Rosenmund's reaction Reagent : H_2 in the presence of Pd (supported over $BaSO_4$) and partially poisoned by addition of Sulphur or quinoline.

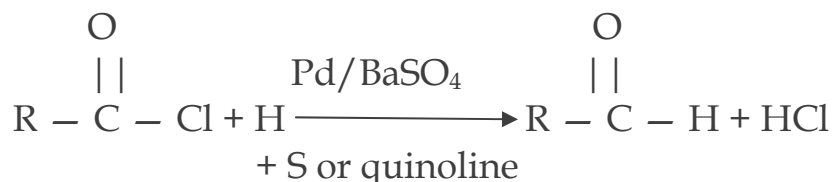

Q 2. Suggest a reason for the large difference in the boiling points of butanol and butanal, although they have same solubility in water

A. The b.p. of butanol is higher than that of butanal because butanol has strong intermolecular H-bonding while butanal has weak dipole-dipole interaction. However both of them form H-bonds with water and hence are soluble.

Q 3. What type of aldehydes undergo Cannizaro reaction ?

A. Aromatic and aliphatic aldehydes which do not contain α -hydrogens.

Q 4. Out of acetophenone and benzophenone, which gives iodoform test ? Write the reaction involved. (The compound should have CH_3CO -group to show the iodoform test.)

A. Acetophenone ($C_6H_5COCH_3$) contains the grouping (CH_3CO attached to carbon) and hence given iodoform test while benzophenone does not contain this group and hence does not give iodoform test.

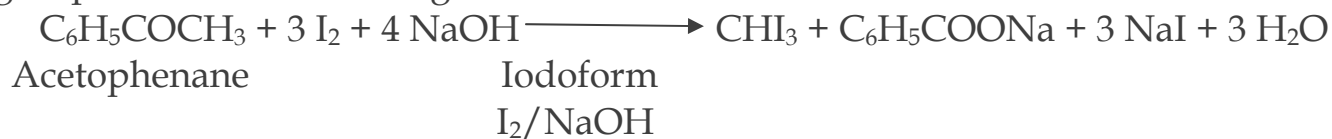

Q5. Give Fehling solution test for identification of aldehyde gp (only equations). Name the aldehyde which does not give Fehling's soln. test.

A. $\text{R} - \text{CHO} - 2 \text{Cu}^{2+} + 5 \text{OH}^- \longrightarrow \text{RCOO}^- + \text{Cu}_2\text{O} + 3 \text{H}_2\text{O}$

Benzaldehyde does not give Fehling soln. test. (Aromatic aldehydes do not give this test.)

Q6. What makes acetic acid a stronger acid than phenol ?

A. Greater resonance stabilization of acetate ion over phenoxide ion.

Q7. Why HCOOH does not give HVZ (Hell Volhard Zelinsky) reaction but CH₃COOH does?

A. CH₃COOH contains α-hydrogens and hence give HVZ reaction but HCOOH does not contain α-hydrogen and hence does not give HVZ reaction

Q8. During preparation of esters from a carboxylic acid and an alcohol in the presence of an acid catalyst, water or the ester formed should be removed as soon as it is formed.

A. The formation of esters from a carboxylic acid and an alcohol in the presence of acid catalyst in a reversible reaction.

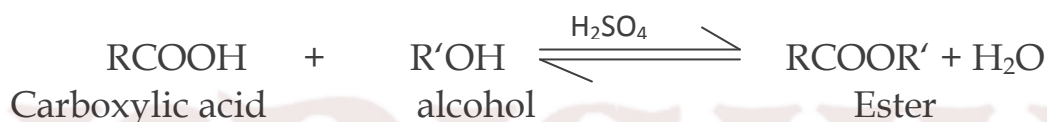

To shift the equilibrium in the forward direction, the water or ester formed should be removed as fast as it is formed

Q 9. Arrange the following compounds in increasing order of their acid strength. Benzoic acid, 4-Nitrobenzoic acid, 3, 4-dinitrobenzoic acid, 4-methoxy benzoic acid.

A. 4-methoxybenzoic acid < benzoic acid < 4-nitrobenzoic acid < 3,4-dinitrobenzoic acid.

Q 10. How is tert-butyl alcohol obtained from acetone? A.

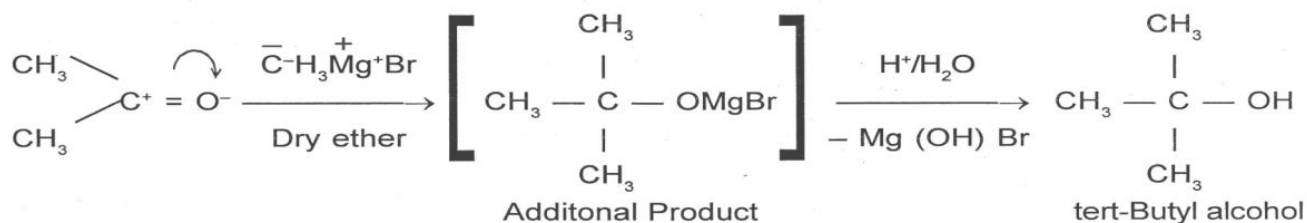

2 / 3 MARKS QUESTIONS

1. Arrange the following compounds in increasing order of their boiling points. Explain by giving reasons.



A. The molecular masses of all these compounds are comparable :



$\text{CH}_3\text{CH}_2\text{OH}$ exists as associated molecule due to extensive intermolecular hydrogen bonding and hence its boiling point is the highest (351 K). Since dipole-dipole interaction are stronger in CH_3CHO than in CH_3OCH_3 , hence boiling point of CH_3CHO (293 K) is much higher than that of CH_3OCH_3 (249 K). Further, molecules of $\text{CH}_3\text{CH}_2\text{CH}_3$ have only weak Vander Waals forces while the molecules of CH_3OCH_3 have little stronger dipole-dipole interactions and hence the boiling point of CH_3OCH_3 is higher (249 K) than that of $\text{CH}_3\text{CH}_2\text{CH}_3$ (231 K). Thus the overall increasing order of boiling points is :

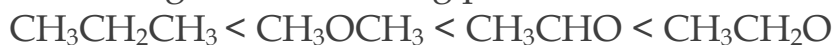

2. Which acid of each pair shown here would you expect to be stronger?

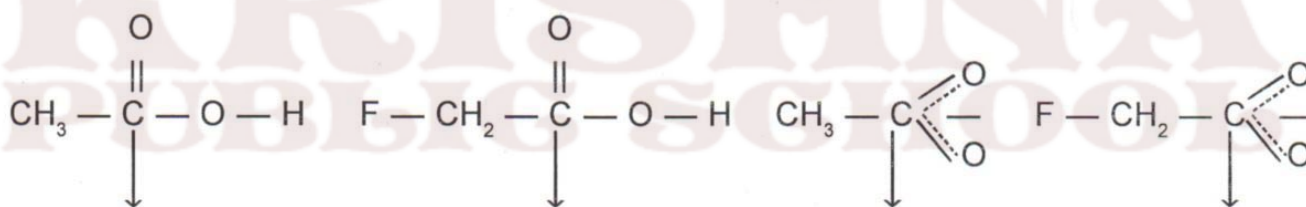

+ I effect of CH_3 gp - I effect of F decreases + I effect of destabil- - I effect stabilizes

Thus due to lesser electron density in the O – H bond and greater stability of FCH_2COO^- ion over CH_3COO^- ion FCH_2COOH is a stronger acid than CH_3COOH .

3. Which acid is stronger and why?

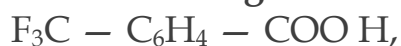

A. CF_3 has a strong(- I) effect.

It stabilises the carboxylate ion
by dispersing the - ve charge.



CH_3 has a weak (+ I) effect.

It stabilises the carboxylate ion
by intensifying the - ve

charge.

Therefore due to greater stability of $\text{F}_3\text{C} - \text{C}_6\text{H}_4 - \text{COO}^-$ (p) ion over $\text{CH}_3 - \text{C}_6\text{H}_4\text{COO}^-$ (p) ion, $\text{F}_3\text{C} - \text{C}_6\text{H}_4 - \text{COOH}$ is a much stronger acid than $\text{CH}_3 - \text{C}_6\text{H}_4 - \text{COOH}$.

4. Arrange the following compounds in increasing order of their reactivity towards HCN. Explain it with proper reasoning.

Acetaldehyde, Acetone, Di-tert-butyl ketone, Methyl tert-butyl ketone.

ANS. Addition of HCN to the carboxyl compounds is a nucleophilic addition reaction.

The reactivity towards HCN addition decreases as the + I effect of the alkyl groups increases and/or the steric hindrance to the nucleophilic attack by CN⁻ at the carboxyl carbon increases. Thus the reactivity decreases in the order.

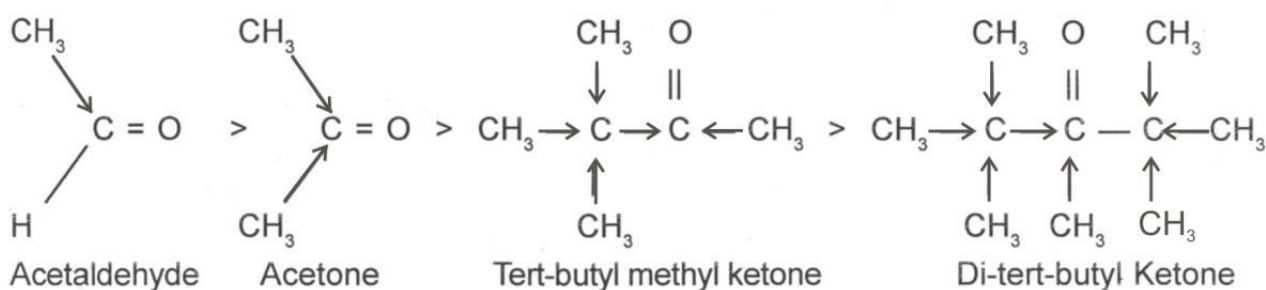

----- + I effect increases -----

----- Steric hindrance increases -----

☐ ----- Reactivity towards HCN addition decreases -----

---☐

In other words, reactivity increases in the reverse order, i. e.

Ditert-butyl Ketone < tert-Butyl methyl Ketone < Acetone <

Acetaldehyde

5. Explain why o-hydroxybenzaldehyde is a liquid at room temperature while p-hydroxybenzaldehyde is a high melting solid.

ANS.

Due to intermolecular H-bonding ortho-hydroxy benzaldehyde exists as discrete molecule whereas due to intermolecular H-bonding, p-hydroxybenzaldehyde exists as associated molecules. To break these intermolecular H-bonds, a large amount of energy is needed. Consequently, p-hydroxybenzaldehyde has a much higher m.p. and b.p. than that of o-hydroxy benzaldehyde. As a result, o-hydroxy benzaldehyde is a liquid at room temperature while p-hydroxy benzaldehyde is a high melting solid.

5 MARKS QUESTIONS

1. Arrange the following compounds in order of their property as indicated-

i) Acetaldehyde, Acetone, di-tert-butyl ketone, Methyl tert-butyl ketone reactivity towards HCN

- di-tert-butyl ketone < Methyl tert-butyl ketone < Acetone < Acetaldehyde

- aldehydes are more reactive towards nucleophilic addition across the $>C=O$ due to steric and electronic reasons.

- Sterically the presence of two relatively large substituents in ketones hinders the approach of nucleophile to carbonyl carbon than in aldehydes having only one such substituent.

- Electronically, the presence of two alkyl groups reduces the electrophilicity of the carbonyl carbon in ketones.

ii) $CH_3CH_2CHBrCOOH$, $CH_3CHBrCH_2COOH$, $(CH_3)_2CHCOOH$, $CH_3CH_2CH_2COOH$ acid strength

$-(CH_3)_2CHCOOH < CH_3CH_2CH_2COOH < CH_3CHBrCH_2COOH < CH_3CH_2CHBrCOOH$

- Electron withdrawing groups like $-Br$ increases the acidity of carboxylic acids by stabilizing the conjugate base through delocalisation of negative charge by negative inductive effect. The closer the electron withdrawing group to the $-COOH$ group, greater is the stabilising effect.

- Electron donating groups decrease the acidity by destabilizing the conjugate base. Greater the number of $-CH_3$ groups, greater the destabilizing effect and lower the acidity.

iii) Benzoic acid, 4-Nitrobenzoic acid, 3,4-Dinitrobenzoic acid, 4-Methoxybenzoic acid (acid strength)

4- Methoxybenzoic acid < Benzoic acid < 4-Nitrobenzoic acid < 3,4-Dinitrobenzoic acid

- Benzoic acid is a stronger acid than aliphatic carboxylic acid due to stabilization of the conjugate base due to resonance.
- Presence of electron withdrawing group-NO₂ on the phenyl ring of aromatic carboxylic acid increases their acidity while electron donating groups-OCH₃ decreases their acidity.

UNIT 9: CO-ORDINATION COMPOUNDS

1	CO-ORDINATION COMPOUND	1. Nomenclature of co-ordination compounds
		2. Hybridisation co-ordination complexes
		3. Isomerization
		4. crystal field theory in octahedral complexes

POINTS TO REMEMBER:

1. Coordination compounds

Coordination compounds are compounds in which a central metal atom or ion is linked to a number of ions or neutral molecules by coordinate bonds or which contain complex ions.

Examples- K₄[Fe(CN)₆]; [Cu(NH₃)₄]SO₄; Ni(CO)₄

2. The main postulates of Werner's theory of coordination compounds

- In coordination compounds metals show two types of linkages or valencies- Primary and Secondary.
- The primary valencies are ionisable and are satisfied by negative ions.
- The secondary valencies are non- ionisable and are satisfied by neutral molecules or negative ions. The secondary valence is equal to the C.N and is fixed for a metal.
- The ions or groups bound by secondary linkages to the metal have characteristic spatial arrangements corresponding to different coordination nos.

3. Difference between a double salt and a complex

Both double salts as well as complexes are formed by the combination of two or more stable compounds in stoichiometric ratio. However, double salts such as carnallite, $KCl \cdot MgCl_2 \cdot 6H_2O$, Mohr's salt, $FeSO_4 \cdot (NH_4)_2SO_4 \cdot 6H_2O$, potash alum, $KAl(SO_4)_2 \cdot 12H_2O$, etc. dissociate into simple ions completely when dissolved in water. However, complex ions such as $[Fe(CN)_6]^{4-}$ of $K_4[Fe(CN)_6]$, do not dissociate into Fe^{2+} and CN^- ions

IMPOTANT TERMINOLOGY

(i) **Coordination entity:** It constitutes the central metal ion or atom bonded to a fixed number of ions or molecules represented within a square bracket.

(ii) **Central atom/ ion:** In a coordination entity, the atom/ion to which a fixed number of ions/groups are bound in a definite geometrical arrangement around it, is called the central atom or ion.

iii) **Ligands:** The neutral or negative ions bound to the central metal or

ion in the coordination entity. These donate a pair/s of electrons to the central metal atom /ion.

Ligands may be classified as-

a) **Monodentate/Unidentate:** Ligands bound to the central metal atom/ion through a single donor atom. Ex- Cl^- ; H_2O ; NH_3 ; NO_2^- .

b) **Didentate:** Ligates through two donor atoms. Ex- $C_2O_4^{2-}$ (ox); $H_2NCH_2CH_2NH_2$ (en)

c) **Polydentate:** which ligates through two or more donor atoms present in a single ligand. Ex- $(EDTA)^{4-}$

d) **Chelating ligands:** Di- or polydentate ligands that uses two or more donor atoms to bind to a single metal ion to form ring- like complexes. (Ox); (edta)

e) **Ambidentate ligand:** A ligand that can ligate through two different atoms, one at a time. Ex- NO_2^- ; SCN^-

v) **Coordination number:** The no. of ligand donor atoms to which the metal is directly bonded through sigma bonds only. It is commonly 4 or 6.

vi) **Counter ions:** The ionisable groups written outside the square bracket. Ex- K^+ in $K_4[Fe(CN)_6]$ OR $3Cl^-$ in $[Co(NH_3)_6]Cl_3$

vii) **Coordination Polyhedron:** The spatial arrangement of the ligand atoms which are directly attached to the central metal atom/ion. They are commonly Octahedral, Square-planar or Tetrahedral

Oxidation number: The charge that the central atom would carry if all the ligands are removed along with their pairs of electrons shared with the central atom. It is represented in parenthesis.

viii) **Homoleptic complexes:** Complexes in which a metal is bonded to only one kind of donor groups. Ex- $[Co(NH_3)_6]^{3+}$

ix) **Heteroleptic complexes:** Complexes in which a metal is bonded to more than one kind of donor groups. Ex- $[Co(NH_3)_4 Cl_2]^+$

5. NAMING OF MONONUCLEAR COORDINATION COMPOUNDS

The principle of additive nomenclature is followed while naming the coordination compounds. The following rules are used-

- i The cation is named first in both positively and negatively charged coordination entities.
- ii The ligands are named in an alphabetical order before the name of the central atom/ion
- iii The name of the anionic ligands end in -o, those of neutral and cationic ligands are the same except aqua for H_2O , ammine for NH_3 , carbonyl for CO and nitrosyl for NO . these are placed within enclosing marks .
- iv When the prefixes mono, di, tri, etc., are used to indicate the number of the individual ligands in the coordination entity. When the names of the ligands include a numerical prefix, then the terms, bis, tris , tetrakis are used, the ligand to which they refer being placed in parenthesis.
- v Oxidation state of the metal in cation, anion, or neutral coordination entity is indicated by roman numeral in parenthesis.
- vi If the complex ion is a cation , the metal is same as the element.
- vii The neutral complex molecule is named similar to that of the complex cation.

6. NAMES OF SOME COMMON LIGANDS

NEGATIVE LIGANDS		CHARGE	NEUTRAL LIGANDS		CHARGE
CN ⁻	Cyano	-1	NH ₃	Ammine	0
Cl ⁻	Chlorido	-1	H ₂ O	Aqua/aquo	0
Br ⁻	Bromido	-1	NO	Nitrosyl	0
F ⁻	Fluorido	-1	CO	Carbonyl	0
SO ₄ ²⁻	Sulphato	-2	PH ₃	Phosphine	0
C ₂ O ₄ ²⁻	Oxalato	-4	CH ₂ -NH ₂ CH ₂ NH ₂	(1,2-Ethane diamine)	0
NH ₂ ⁻	Amido	-1	POSITIVE LIGANDS		
NH ²⁻	Imido	-2	NH ₂ -NH ₃ ⁺	Hydrazinium	+1
ONO ⁻	Nitrito-O	-1	NO ⁺	Nitrosonium	+1
NO ₂ ⁻	Nitro	-1	NO ₂ ⁺	Nitronium	+1

NO_3^-	Nitrato	-1			
SCN^-	Thiocyanato	-1			
NCS^-	Isothiocyanato	-1			
$\text{CH}_2(\text{NH}_2)\text{COO}^-$	Glycinato	-1			
$-\text{OH}$	Hydroxo	-1			

KRISHNA
PUBLIC SCHOOL

7. ISOMERISM IN COORDINATION COMPOUNDS

Two or more substances having the same molecular formula but different spatial arrangements are called isomers and the phenomenon is called isomerism. Coordination compounds show two main types of isomerism-

A) Structural Isomerism

B) Stereoisomerism

STRUCTURAL ISOMERISM:- It arises due to the difference in structures of coordination compounds. It is further subdivided into the following types-

1) **Ionisation isomerism :** This form of isomerism arises when the counter ion in a complex salt is itself a potential ligand and can displace a ligand which can then become the counter ion. An example is provided by the ionization isomers $[\text{Co}(\text{NH}_3)_5\text{SO}_4]\text{Br}$ and $[\text{Co}(\text{NH}_3)_5\text{Br}]\text{SO}_4$.

2) **Hydrate or solvate isomerism:** This form of isomerism is known as 'hydrate isomerism' in case where water is involved as a solvent. This is similar to ionisation isomerism. Solvate isomers differ by whether or not a solvent molecule is directly bonded to the metal ion or merely present as free solvent molecules in the crystal lattice. An example is provided by the aqua complex $[\text{Cr}(\text{H}_2\text{O})_6]\text{Cl}_3$ (violet) and its solvate isomer $[\text{Cr}(\text{H}_2\text{O})_5\text{Cl}]\text{Cl}_2 \cdot \text{H}_2\text{O}$ (grey-green).

3) **Linkage Isomerism:** Linkage isomerism arises in a coordination compound containing ambidentate ligand. A simple example is provided by complexes containing the thiocyanate ligand, NCS^- , which may bind through the nitrogen to give $\text{M}-\text{NCS}$ or through sulphur to give $\text{M}-\text{SCN}$.

4) **Coordination isomerism:** It arises from the interchange of ligands between cationic and anionic entities of different metal ions present in a complex .
Example $[\text{Co}(\text{NH}_3)_6][\text{Cr}(\text{CN})_6]$ & $[\text{Cr}(\text{NH}_3)_6][\text{Co}(\text{CN})_6]$

STEREOISOMERISM: Stereo isomers have the same chemical formula and chemical bonds but they have different spatial arrangement. They are of two kinds

A. Geometrical isomerism

B. Optical isomerism

GEOMETRICAL ISOMERISM- This type of isomerism arises in heteroleptic complexes due to different possible geometric arrangements of the ligands. Important examples of this behaviour are found with coordination numbers 4 and 6. In a square planar complex of formula $[\text{MX}_2\text{L}_2]$ (X and L are unidentate), the two ligands X may be arranged adjacent to each other in a cis isomer, or opposite to each other in a trans isomer $[\text{MABXL}]$ -Where A,B,X,L are unidentates
Two cis- and one trans- isomers are possible

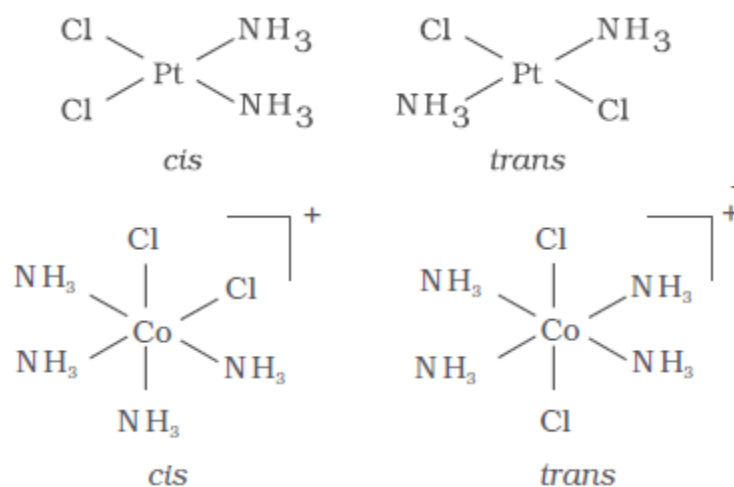

Another type of geometrical isomerism occurs in octahedral coordination entities of the type $[Ma_3b_3]$ like $[Co(NH_3)_3(NO_2)_3]$. If three donor atoms of the same ligands occupy adjacent positions at the corners of an octahedral face, we have the facial (*fac*) isomer. When the positions are around the meridian of the octahedron, we get the meridional (*mer*) isomer.

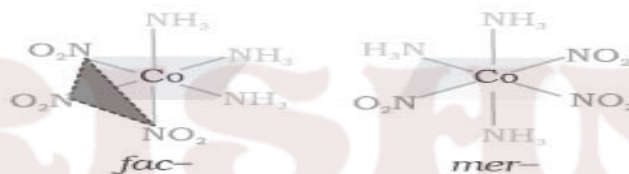

b) **OPTICAL ISOMERISM:** Optical isomers are mirror images that cannot be superimposed on one another. These are called as enantiomers. The molecules or ions that cannot be superimposed are called chiral. The two forms are called dextro (*d*) and laevo (*l*) depending upon the direction they rotate the plane of polarised light in a polarimeter (*d* rotates to the right, *l* to the left). Optical isomerism is common in octahedral complexes involving didentate ligands. In a coordination entity of the type $[CoCl_2(en)_2]^{2+}$, only the *cis*-isomer shows optical activity

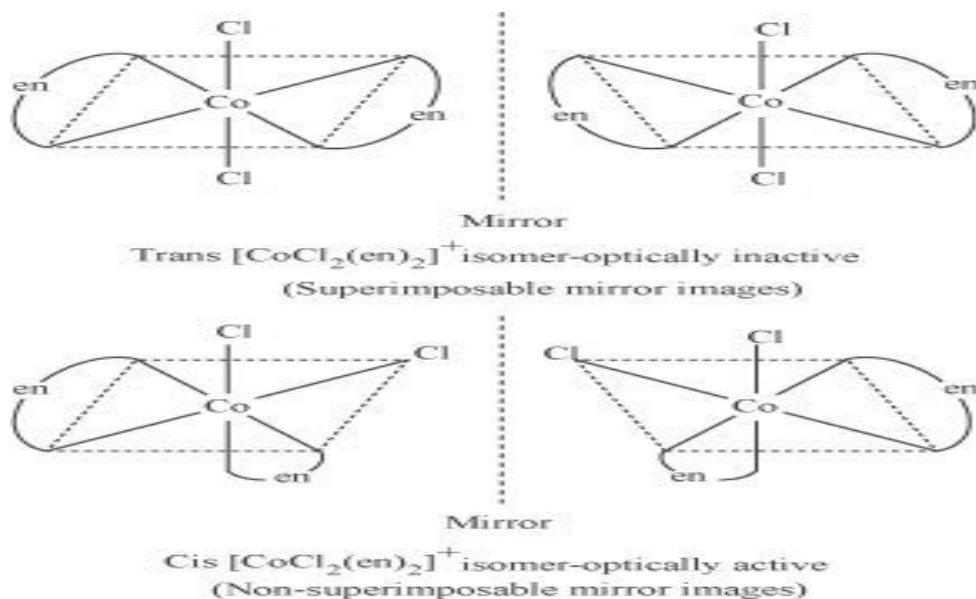

TYPES OF HYBRIDISATION

Coordination number	Type of hybridisation	Acquired geometry
4	sp^3	Tetrahedral
4	dsp^2	Square planar
5	sp^3d	Trigonal bipyramidal
6	sp^3d^2	Octahedral
6	d^2sp^3	Octahedral

8. CRYSTAL FIELD THEORY:

1. The metal-ligand bond is ionic arising purely from electrostatic interactions between the metal ion and the ligand.
2. Ligands are treated as point charges or dipoles in case of anions and neutral molecules.
3. In an isolated gaseous metal atom or ion the five d-orbitals are degenerate.
4. Degeneracy is maintained if a spherically symmetrical field of negative charges surrounds the metal /ion.
5. In a complex the negative field becomes asymmetrical and results in splitting of the d-orbitals.

A) CRYSTAL FIELD SPLITTING IN OCTAHEDRAL COORDINATION ENTITIES

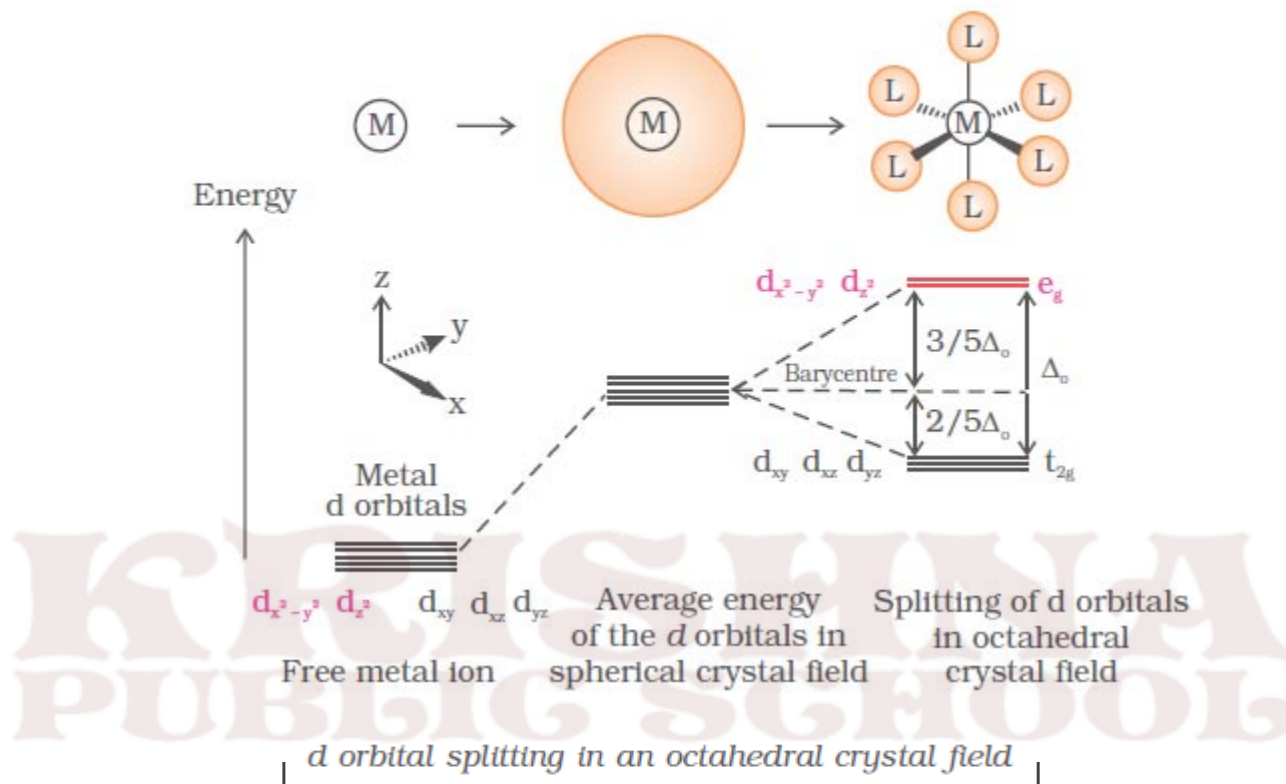

1. For d^4 ions, two possible patterns of electron distribution arise:

(i) If $\Delta_o < P$, the fourth electron enters one of the e_g orbitals giving the

configuration $t^3_{2g} e^1_g$. Ligands for which $\Delta_o < P$ are known as weak

field ligands and form high spin complexes.

(ii) If $\Delta_o > P$, it becomes more energetically favourable for the fourth electron to occupy a t_{2g} orbital with configuration $t^4_{2g} e^0_g$. Ligands which produce this effect are known as strong field ligands and form low spin complexes.

B) CRYSTAL FIELD SPLITTING IN TETRAHEDRAL COORDINATION ENTITIES

1. The four surrounding ligands approach the central metal atom/ion along the planes between the axes.

2. The t_{2g} orbitals are raised in energy $(2/5) \Delta_t$.

3. The two e_g orbitals are lowered in energy $(3/5) \Delta_t$.

4. The splitting is smaller as compared to octahedral field splitting, $\Delta_t = (4/9) \Delta_o$.

5. Pairing of electrons is rare and thus complexes have generally high spin configurations.

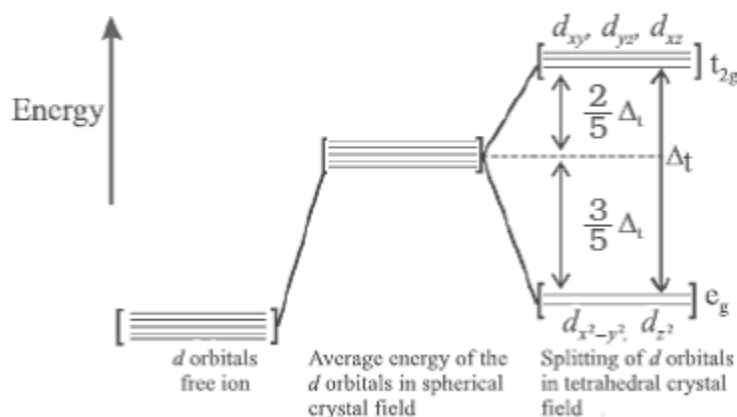

BONDING IN METAL CARBONYLS

The metal-carbon bond in metal carbonyls possess both σ and π character. The M-C σ bond

is formed by the donation of lone pair of electrons on the carbonyl carbon into a vacant orbital of the metal. The M-C π bond is formed by the donation of a pair of electrons from a filled d orbital of metal into the vacant antibonding π^* orbital of carbon monoxide. The metal to ligand bonding creates a synergic effect which strengthens the bond between CO and the metal.

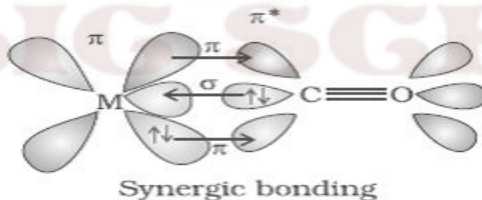

SOLVED QUESTIONS

1 MARK QUESTIONS

1. What are ambidentate ligands? Give two examples for each.

ANS. Ambidentate ligands are ligands that can attach themselves to the central metal atom through two different atoms. For example:



(The donor atom is N)

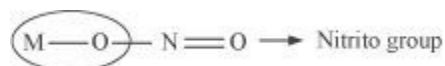

(The donor atom is oxygen)



(The donor atom is S)



(The donor atom is N)

Q2. Using IUPAC norms write the formula for the following: Tetrahydroxozincate(II)

ANS. $[\text{Zn}(\text{OH})_4]^{2-}$

Q3. Using IUPAC norms write the formula for the following: Hexaamminecobalt(III) sulphate

ANS. $[\text{Co}(\text{NH}_3)_6]_2 (\text{SO}_4)_3$

Q4. Using IUPAC norms write the formula for the following: Pentaamminenitrito-O-cobalt(III)

ANS. $[\text{Co}(\text{ONO}) (\text{NH}_3)_5]^{2+}$

Q5. Using IUPAC norms write the systematic name of the following: $[\text{Co}(\text{NH}_3)_6]\text{Cl}_3$

ANS. Hexaamminecobalt(III) chloride

Q6. Using IUPAC norms write the systematic name of the following:

$[\text{Pt}(\text{NH}_3)_2\text{Cl}(\text{NH}_2\text{CH}_3)]\text{Cl}$

ANS. Diamminechlorido(methylamine) platinum(II) chloride

Q7. Using IUPAC norms write the systematic name of the following: $[\text{Co}(\text{en})_3]^{3+}$

ANS. Tris(ethane-1, 2-diammine) cobalt(III) ion

Q8. Draw the structures of optical isomers of: $c[\text{Cr}(\text{C}_2\text{O}_4)_3]^{3-}$

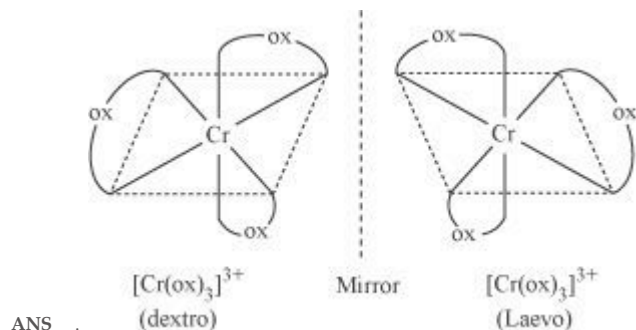

Q9. What is meant by the chelate effect? Give an example.

ANS. When a ligand attaches to the metal ion in a manner that forms a ring, then the metal-ligand association is found to be more stable.

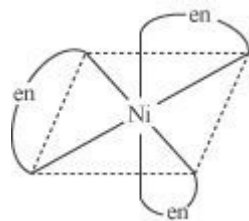

2 / 3 MARK QUESTIONS

Q1. What is spectrochemical series? Explain the difference between a weak field ligand and a strong field ligand.

ANS. A spectrochemical series is the arrangement of common ligands in the increasing order of their crystal-field splitting energy (CFSE) values.

$I^- < Br^- < S_2^{2-} < SCN^- < Cl^- < N_3^- < F^- < OH^- < C_2O_4^{2-} \sim H_2O < NCS^- \sim H^- < CN^- < NH_3 < en \sim SO_3^{2-} < NO_2^- < phen < CO$

Q2. $[Cr(NH_3)_6]^{3+}$ is paramagnetic while $[Ni(CN)_4]^{2-}$ is diamagnetic. Explain why?

ANS. Cr is in the +3 oxidation state i.e., d^3 configuration. Also, NH_3 is a weak field ligand that does not cause the pairing of the electrons in the 3d orbital.



Therefore, it undergoes d^2sp^3 hybridization and the electrons in the 3d orbitals remain unpaired. Hence, it is paramagnetic in nature.

In $[Ni(CN)_4]^{2-}$, Ni exists in the +2 oxidation state i.e., d^8 configuration.



CN^- is a strong field ligand. It causes the pairing of the 3d orbital electrons. Then, Ni^{2+} undergoes dsp^2 hybridization.

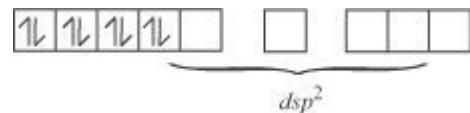

Q3. A solution of $[Ni(H_2O)_6]^{2+}$ is green but a solution of $[Ni(CN)_4]^{2-}$ is colourless. Explain.

ANS. In $[Ni(H_2O)_6]^{2+}$, $H_2\ddot{O}$ is a weak field ligand. Therefore, there are unpaired electrons in Ni^{2+} . In this complex, the d electrons from the lower energy level can be excited to the higher energy level i.e., the possibility of d-d transition is present. Hence, $[Ni(H_2O)_6]^{2+}$ is coloured.

In $[\text{Ni}(\text{CN})_4]^{2-}$, the electrons are all paired as CN^- is a strong field ligand. Therefore, d-d transition is not possible in $[\text{Ni}(\text{CN})_4]^{2-}$. Hence, it is colourless. As there are no unpaired electrons, it is diamagnetic.

Q2. Draw all the isomers (geometrical and optical) of:

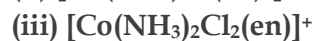
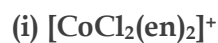

ANS. (i) $[\text{CoCl}_2(\text{en})_2]^+$

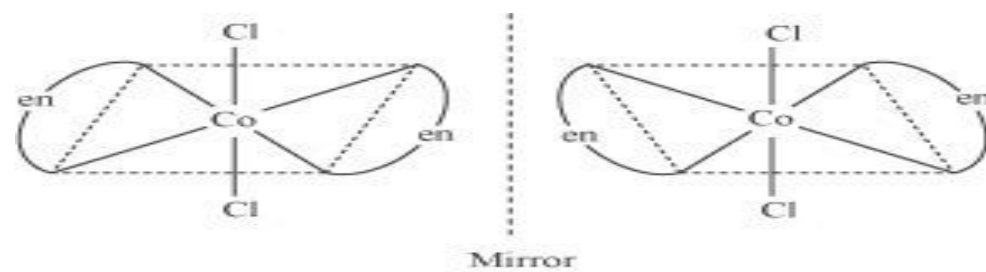

Trans $[\text{CoCl}_2(\text{en})_2]^+$ isomer—optically inactive

(Superimposable mirror images)

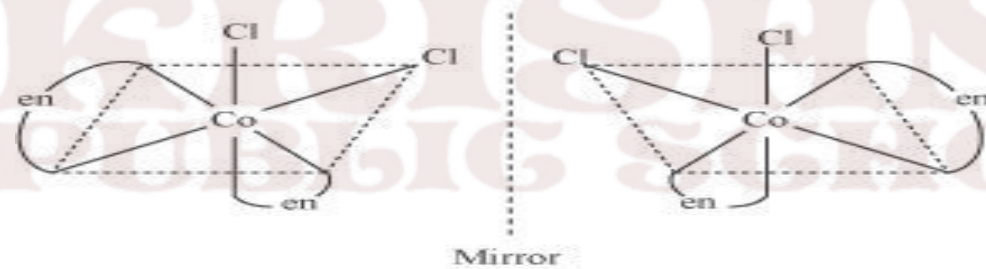

Cis $[\text{CoCl}_2(\text{en})_2]^+$ isomer—optically active

(Non-superimposable mirror images)

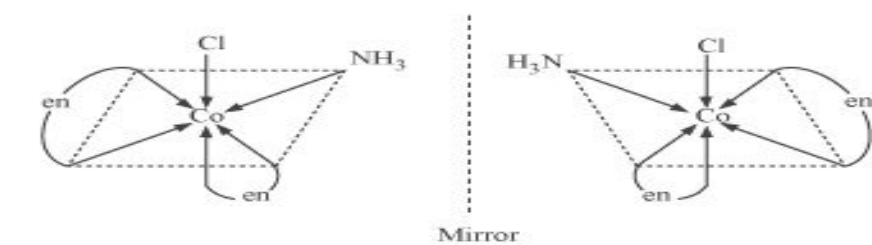
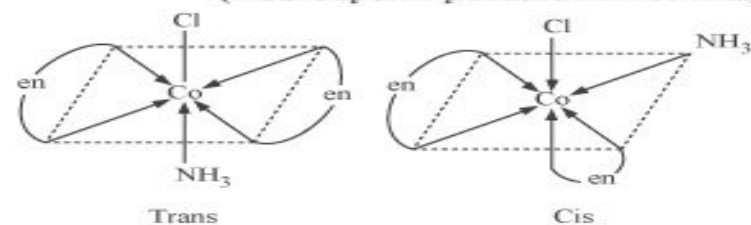

In total, three isomers are possible.

Trans-isomers are optically inactive.

Cis-isomers are optically active.

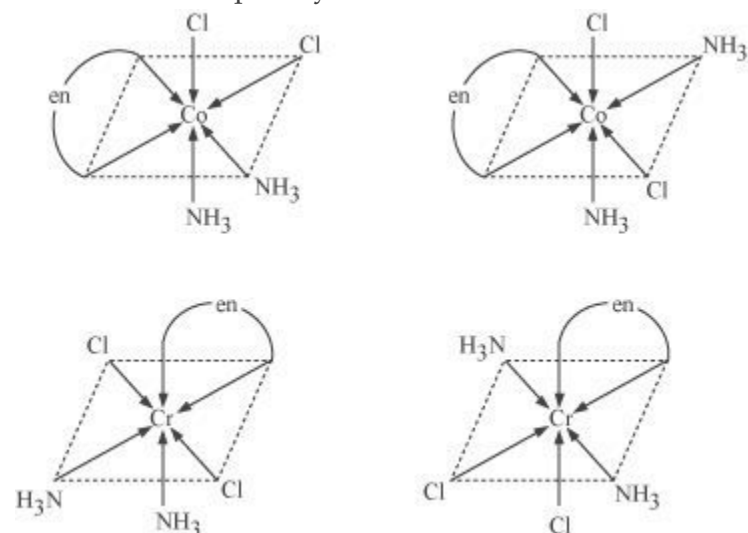

(iii) $[\text{Co}(\text{NH}_3)_2\text{Cl}_2(\text{en})]^+$

Q3. Write all the geometrical isomers of $[\text{Pt}(\text{NH}_3)(\text{Br})(\text{Cl})(\text{py})]$ and how many of these will exhibit optical isomers?

ANS. $[\text{Pt}(\text{NH}_3)(\text{Br})(\text{Cl})(\text{py})]$

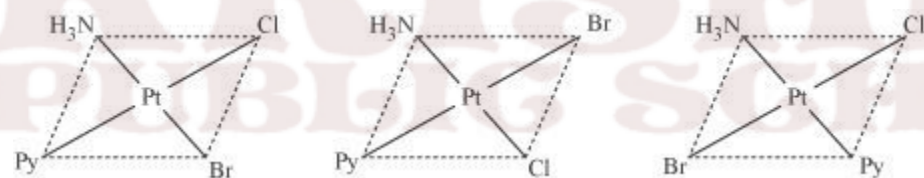

From the above isomers, none will exhibit optical isomers. Tetrahedral complexes rarely show optical isomerization. They do so only in the presence of unsymmetrical chelating agents.

Q4. What is meant by stability of a coordination compound in solution? State the factors which govern stability of complexes.

ANS. The stability of a complex in a solution refers to the degree of association between the two species involved in a state of equilibrium. Stability can be expressed quantitatively in terms of stability constant or formation constant.

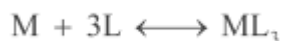

$$\text{Stability constant, } \beta = \frac{[\text{ML}_3]}{[\text{M}][\text{L}]^3}$$

For this reaction, the greater the value of the stability constant, the greater is the proportion of ML_3 in the solution.

5 MARKS QUESTIONS

Q1. (a) Discuss the nature of bonding in the following coordination entities on the basis of valence bond theory:

(i) $[\text{Fe}(\text{CN})_6]^{4-}$ (ii) $[\text{FeF}_6]^{3-}$ (iii) $[\text{Co}(\text{C}_2\text{O}_4)_3]^{3-}$ (iv) $[\text{CoF}_6]^{3-}$

ANS. (i) $[\text{Fe}(\text{CN})_6]^{4-}$ In the above coordination complex, iron exists in the +II oxidation state. Fe^{2+} : Electronic configuration is $3d^6$ Orbitals of Fe^{2+} ion:



As CN^- is a strong field ligand, it causes the pairing of the unpaired 3d electrons. Since there are six ligands around the central metal ion, the most feasible hybridization is d^2sp^3 . d^2sp^3 hybridized orbitals of Fe^{2+} are:

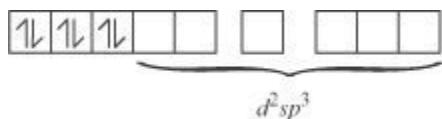

6 electron pairs from CN^- ions occupy the six hybrid d^2sp^3 orbitals. Then,

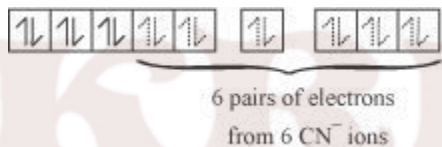

Hence, the geometry of the complex is octahedral and the complex is diamagnetic (as there are no unpaired electrons).

(ii) $[\text{FeF}_6]^{3-}$

In this complex, the oxidation state of Fe is +3.

Orbitals of Fe^{+3} ion:

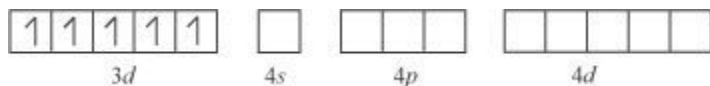

There are 6 F^- ions. Thus, it will undergo d^2sp^3 or sp^3d^2 hybridization. As F^- is a weak field ligand, it does not cause the pairing of the electrons in the 3d orbital. Hence, the most feasible hybridization is sp^3d^2 . sp^3d^2 hybridized orbitals of Fe are:

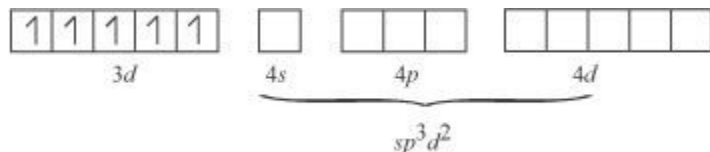

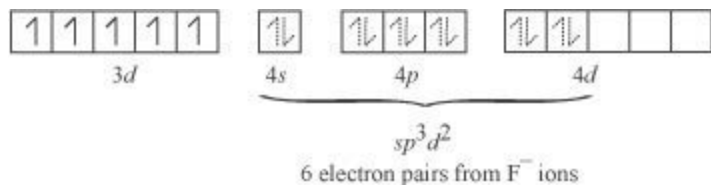

Hence, the geometry of the complex is found to be octahedral.

(iii) $[Co(C_2O_4)_3]^{3-}$

Cobalt exists in the +3 oxidation state in the given complex. Orbitals of Co^{3+} ion: Oxalate is a weak field ligand. Therefore, it cannot cause the pairing of the 3d orbital electrons. As there are 6 ligands, hybridization has to be either sp^3d^2 or d^2sp^3 hybridization. sp^3d^2 hybridization of Co^{3+} :

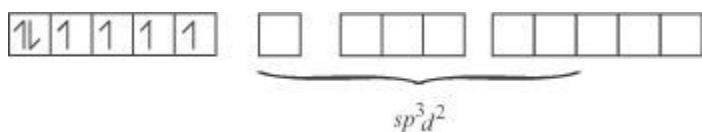

The 6 electron pairs from the 3 oxalate ions (oxalate anion is a bidentate ligand) occupy these sp^3d^2 orbitals.

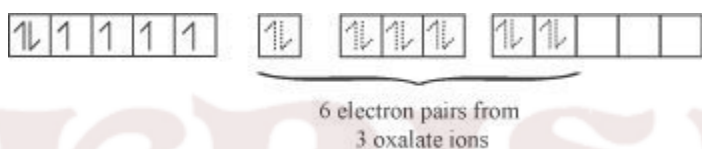

Hence, the geometry of the complex is found to be octahedral.

(iv) $[CoF_6]^{3-}$ -Cobalt exists in the +3 oxidation state.

Orbitals of Co^{3+} ion:

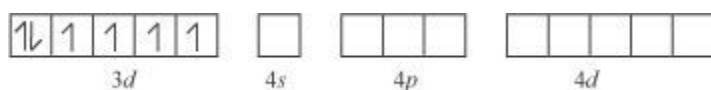

Again, fluoride ion is a weak field ligand. It cannot cause the pairing of the 3d electrons. As a result, the Co^{3+} ion will undergo sp^3d^2 hybridization. sp^3d^2 hybridized orbitals of Co^{3+} ion are:

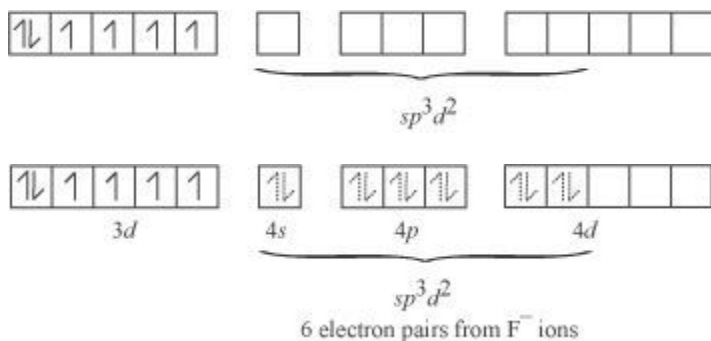

Hence, the geometry of the complex is octahedral and paramagnetic.

Q3. Write down the IUPAC name for each of the following complexes and indicate the oxidation state, electronic configuration and coordination number. Also give stereochemistry and magnetic moment of the complex:

(i) $K[Cr(H_2O)_2(C_2O_4)_2] \cdot 3H_2O$ (ii) $[Co(NH_3)_5Cl]Cl_2$ ANS. (i) Potassium diaquadioxalatochromate (III) trihydrate.

Oxidation state of chromium = 3

Electronic configuration: $3d^3: t_{2g}^3$

Coordination number = 6

Shape: octahedral

Stereochemistry:

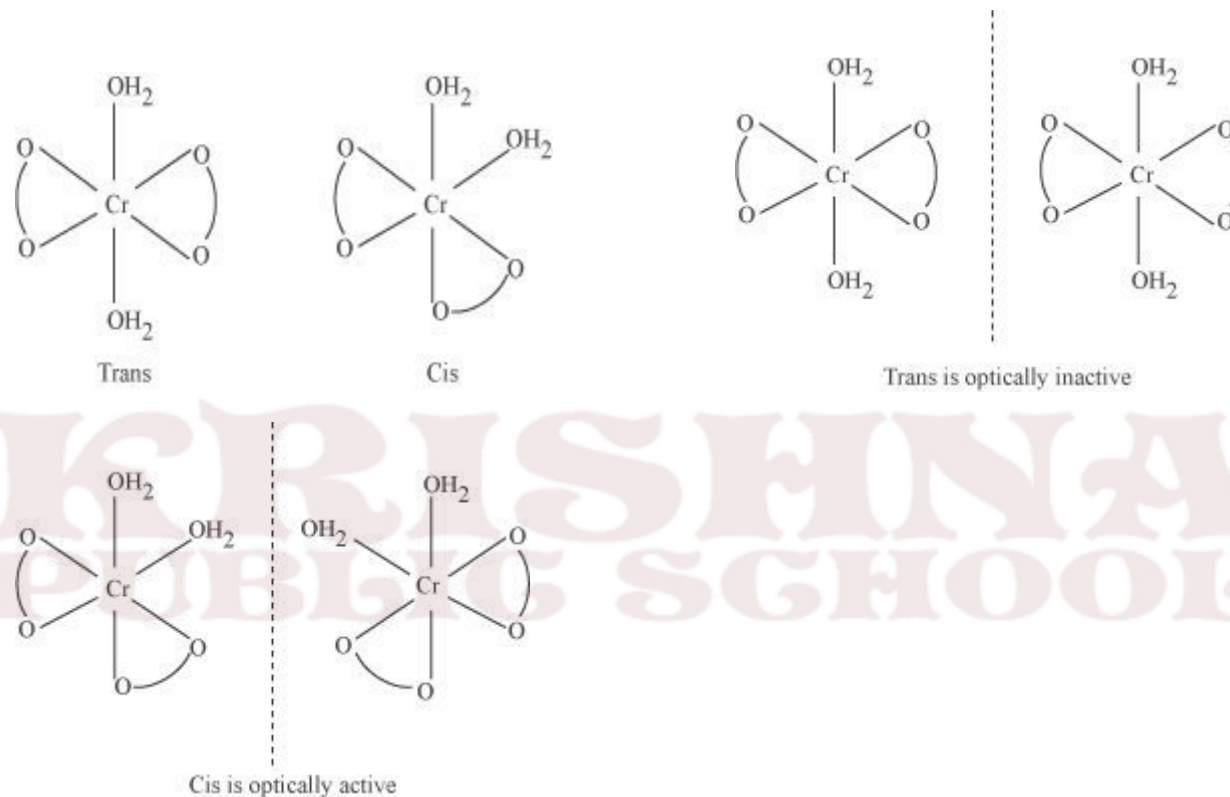

Magnetic moment, $\mu = \sqrt{n(n+2)}$

$$= \sqrt{3(3+2)}$$

$$= \sqrt{15}$$

~ 4BM

(ii) $[Co(NH_3)_5Cl]Cl_2$

IUPAC name: Pentaamminechloridocobalt(III) chloride

Oxidation state of Co = +3

Coordination number = 6

Shape: octahedral.

Electronic configuration: $d^6: t_{2g}^6$.

Stereochemistry:

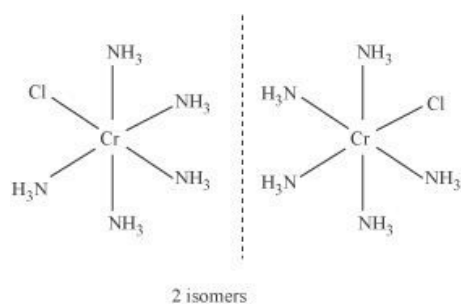

Magnetic Moment = 0

LEVEL 1

1. Why do tetrahedral complex not show geometrical isomerism?
2. Why does the colour changes on heating $[\text{Ti}(\text{H}_2\text{O})_6]^{3+}$.
3. $[\text{Fe}(\text{H}_2\text{O})_6]^{3+}$ is strongly paramagnetic whereas $[\text{Fe}(\text{CN})_6]^{3-}$ is weakly paramagnetic. Explain.
4. What happens when potassium ferrocyanide solution is added to a ferric salt solution?

LEVEL 2

5. A coordination compound has a formula $(\text{CoCl}_3 \cdot 4\text{NH}_3)$. It does not liberate NH_3 but precipitates chloride ion as AgCl . Give the IUPAC name of the complex and write its structural formula.
6. Write the correct formula for the following co-ordination compounds. $\text{CrCl}_3 \cdot 6\text{H}_2\text{O}$ (Violet, with 3 Chloride ions/ Unit formula) $\text{CrCl}_3 \cdot 6\text{H}_2\text{O}$
(Light green colour with 2 Chloride ions/ unit formula)
7. Give the electronic configuration of the d-orbitals of Ti in $[\text{Ti}(\text{H}_2\text{O})_6]^{3+}$ ion in an octahedral crystal field.
8. $\text{Co}(\text{II})$ is stable in aqueous solution but in the presence of strong ligands and air, it can get oxidized to $\text{Co}(\text{III})$. (Atomic Number of cobalt is 27). Explain.
9. Give a chemical test to distinguish between $[\text{Co}(\text{NH}_3)_5\text{Br}]\text{SO}_4$ and $[\text{Co}(\text{NH}_3)_5\text{Br}]\text{SO}_4\text{Br}$. Name the type of isomerism exhibited by these compounds.
10. What is the coordination entity formed when excess of aqueous KCN is added to an aqueous solution of copper sulphate? Why is that no precipitate of copper sulphate is obtained when H_2S (g) is passed through this solution?

LEVEL 3

11. Aqueous copper sulphate solution (blue in colour) gives a green precipitate with aqueous potassium fluoride, a bright green solution with aqueous potassium chloride. Explain these experimental results.

12. A metal complex having the composition $\text{Cr}(\text{NH}_4)_4\text{Cl}_2\text{Br}$ has been isolated in two forms, A and B. The form A reacts with AgNO_3 solution to give a white precipitate readily soluble in dilute aqueous ammonia whereas B give a pale yellow precipitate soluble in concentrated ammonia solution. Write the formulae of A and B and write their IUPAC names.

13. Explain the following

i. All octahedral complexes of Ni^{2+} must be outer orbital complexes. ii.

NH_4^+ ion does not form any complex.

iii. $(\text{SCN})^{-1}$ ion is involved in linkage isomerism in co-ordination compounds.

14. A metal ion Mn^{+} having d^4 valence electronic configuration combines with three didentate ligands to form complexes. Assuming $\Delta_o > P$ Draw the diagram showing d orbital splitting during this complex formation. Write the electronic configuration of the valence electrons of the metal Mn^{+} ion in terms of t_{2g} and e_g . What type of the hybridization will Mn^{+} ion have? Name the type of isomerism exhibited by this complex.

15. The coordination no. of Ni^{2+} is 4.

$\text{NiCl}_2 + \text{KCN}(\text{excess}) \rightarrow \text{A}(\text{a cyano complex})$

$\text{A} + \text{Conc HCl}(\text{excess}) \rightarrow \text{B}(\text{a chloro complex})$

i) Write IUPAC name of A and B

ii) Predict the magnetic nature of A and B

iii) Write hybridization of Ni in A and B

16. Explain the following

i. $\text{Cu}(\text{OH})_2$ is soluble in ammonium hydroxide but not in sodium hydroxide solution. ii.

EDTA is used to cure lead poisoning

iii. Blue coloured solution of $[\text{CoCl}_4]^{2-}$ changes to pink on reaction with HgCl_2 .

1 MARK QUESTIONS

Q1. Write the formula for the following coordination compound:

Tetraammineaquachloridocobalt(III) chloride

Q2. Write the IUPAC name of the following coordination compound:



- Q3. Why is geometrical isomerism not possible in tetrahedral complexes having two different types of unidentate ligands coordinated with the central metal ion ?
- Q4. Out of the following two coordination entities which is chiral (optically active)?
(a) *cis*- $[\text{CrCl}_2(\text{ox})_2]^{3-}$ (b) *trans*- $[\text{CrCl}_2(\text{ox})_2]^{3-}$
- Q5. The spin only magnetic moment of $[\text{MnBr}_4]^{2-}$ is 5.9 BM. Predict the geometry of the complex ion?
- Q6. $[\text{NiCl}_4]^{2-}$ is paramagnetic while $[\text{Ni}(\text{CO})_4]$ is diamagnetic though both are tetrahedral. Why?

2 MARKS QUESTIONS

- Q1. Draw structures of geometrical isomers of $[\text{Fe}(\text{NH}_3)_2(\text{CN})_4]^-$
- Q2. Indicate the type of isomerism exhibited by the following complex and draw the structures for these isomers:
 $[\text{Co}(\text{en})_3]\text{Cl}_3$
- Q3. Give evidence that $[\text{Co}(\text{NH}_3)_5\text{Cl}]\text{SO}_4$ and $[\text{Co}(\text{NH}_3)_5\text{SO}_4]\text{Cl}$ are ionization isomers.
- Q4. Calculate the overall complex dissociation equilibrium constant for the $[\text{Cu}(\text{NH}_3)_4]^{2+}$ ion, given that β_4 for this complex is 2.1×10^{13} .
- Q5. What is meant by unidentate ligand? Give two examples.
- Q6. What is meant by didentate ligand? Give two examples.
- Q7. What is meant by ambidentate ligands? Give two examples.
- Q8. Draw the structures of optical isomers of:
 $[\text{Cr}(\text{C}_2\text{O}_4)_3]^{3-}$
- Q9. Discuss the nature of bonding in metal carbonyls.
- Q10. What is meant by the *chelate effect*? Give an example.
- Q11. Draw the structures of:
(i) $\text{Ni}(\text{CO})_4$ (ii) $\text{Fe}(\text{CO})_5$

3 MARKS QUESTIONS

- Q1. Discuss the nature of bonding in the following coordination entities on the basis of valence bond theory:
(i) $[\text{Fe}(\text{CN})_6]^{4-}$ (ii) $[\text{FeF}_6]^{3-}$ (iii) $[\text{Co}(\text{C}_2\text{O}_4)_3]^{3-}$
Also predict their magnetic behaviour.
- Q2. What is crystal field splitting energy? Draw figure to show the splitting of *d* orbitals in an octahedral crystal field. How does the magnitude of Δ_o decide the actual configuration of *d* orbitals in a coordination entity?
- Q3. Discuss briefly giving an example in each case the role of coordination compounds in:
(i) biological systems (iii) analytical chemistry

(ii) medicinal chemistry .

UNIT 13: AMINES

2.	Amines	1. Ammonolysis of alkylhalides, Gabriel
		Phthalimide synthesis, Hoffmann Bromamide Degradation. 2. Basic character of Amines(pK_b) and comparisons in gaseous and aqueous phase. 3. Carbylamine Reaction ,Hinsberg's Test. 4. Electrophilic substitution. 5. Diazonium salts –reactions

IUPAC NOMENCLATURE

**KRISHNA
PUBLIC SCHOOL**

**KRISHNA
PUBLIC SCHOOL**

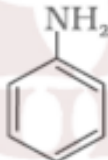
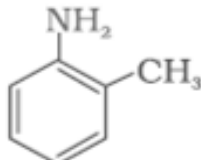
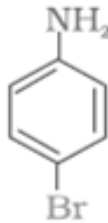
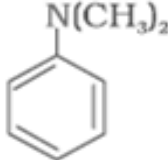
Amine	IUPAC name
$\text{CH}_3\text{-CH}_2\text{-NH}_2$	Ethanamine
$\text{CH}_3\text{-CH}_2\text{-CH}_2\text{-NH}_2$	Propan-1-amine
$\begin{array}{c} \text{CH}_3\text{-CH-CH}_3 \\ \\ \text{NH}_2 \end{array}$	Propan-2-amine
$\begin{array}{c} \text{CH}_3\text{-N-CH}_2\text{-CH}_3 \\ \\ \text{H} \end{array}$	N-Methylethanamine
$\begin{array}{c} \text{CH}_3\text{-N-CH}_3 \\ \\ \text{CH}_3 \end{array}$	N,N-Dimethylmethanamine
$\begin{array}{c} \text{C}_2\text{H}_5\text{-N-CH}_2\text{-CH}_2\text{-CH}_2\text{-CH}_3 \\ \\ \text{C}_2\text{H}_5 \end{array}$	N,N-Diethylbutan-1-amine
$\text{NH}_2\text{-CH}_2\text{-CH}=\text{CH}_2$	Prop-2-en-1-amine
$\text{NH}_2\text{-(CH}_2\text{)}_6\text{-NH}_2$	Hexane-1,6-diamine
	Aniline or Benzenamine
	2-Aminotoluene
	4-Bromobenzenamine or 4-Bromoaniline
	N,N-Dimethylbenzenamine

NAME REACTIONS

1. Gabriel phthalimide synthesis

Gabriel synthesis is used for the preparation of primary amines. Phthalimide on treatment with ethanolic potassium hydroxide forms potassium salt of phthalimide which on heating with alkyl halide followed by alkaline hydrolysis produces the corresponding primary amine. Aromatic primary amines cannot be prepared by this method because aryl halides do not undergo nucleophilic substitution with the anion formed by phthalimide.

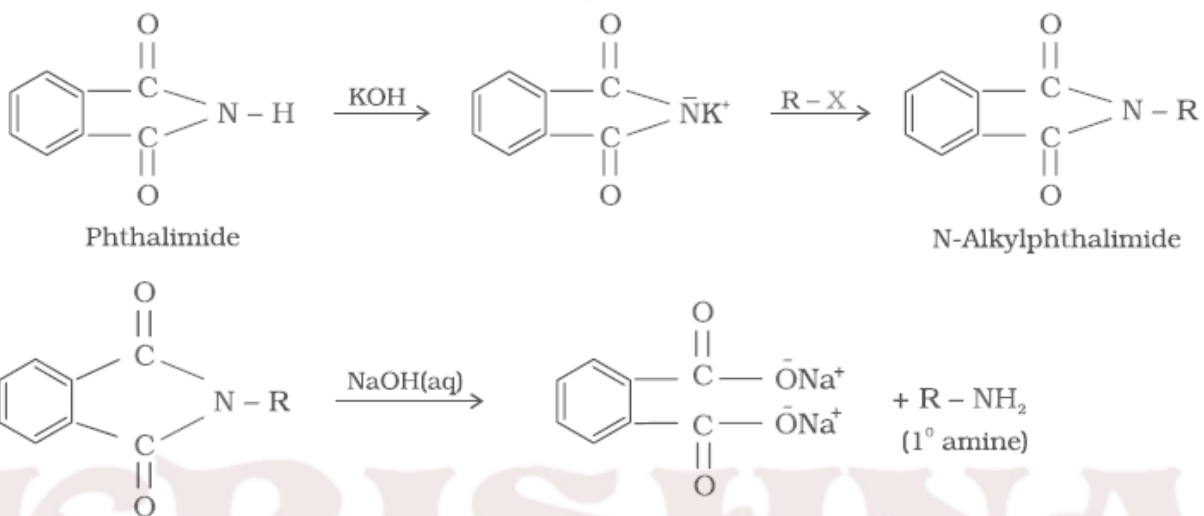

2. Hoffmann bromamide degradation reaction

Hoffmann developed a method for preparation of primary amines by treating an amide with bromine in an aqueous or ethanolic solution of sodium hydroxide. The amine so formed contains one carbon less than that present in the amide.

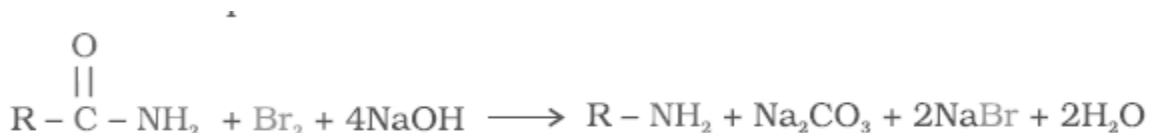

3. Carbylamine reaction

Aliphatic and aromatic primary amines on heating with chloroform and ethanolic potassium hydroxide form isocyanides or carbylamines which are foul smelling substances. Secondary and tertiary amines do not show this reaction. This reaction is known as carbylamine reaction or isocyanide test and is used as a test for primary amines.



4. Hinsberg Test:

Benzenesulphonyl chloride ($C_6H_5SO_2Cl$), which is also known as Hinsberg's reagent, reacts with primary and secondary amines to form sulphonamides.

(a) The reaction of benzenesulphonyl chloride with primary amine yields N-ethylbenzenesulphonyl amide.

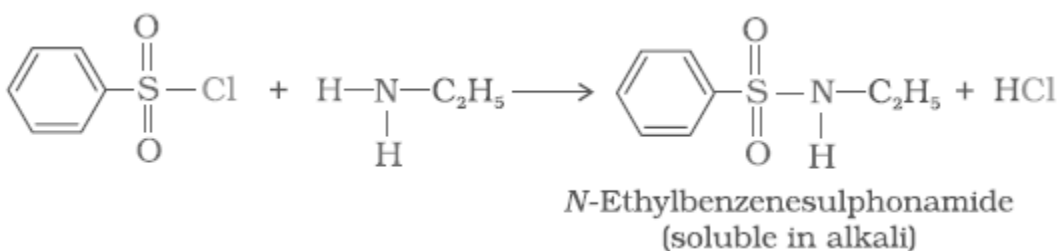

The hydrogen attached to nitrogen in sulphonamide is strongly acidic due to the presence of strong electron withdrawing sulphonyl group. Hence, it is soluble in alkali.

(b) In the reaction with secondary amine, N,N-diethylbenzenesulphonamide is formed.

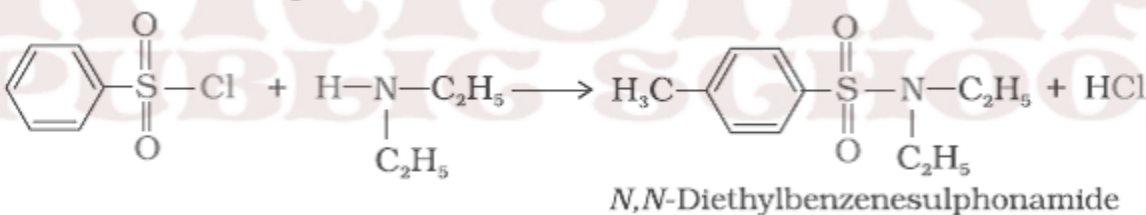

Since N, N-diethylbenzene sulphonamide does not contain any hydrogen atom attached to nitrogen atom, it is not acidic and hence insoluble in alkali.

(c) Tertiary amines do not react with benzenesulphonyl chloride. This property of amines reacting with benzenesulphonyl chloride in a different manner is used for the distinction of primary, secondary and tertiary amines and also for the separation of a mixture of amines.

5. Sandmeyer Reaction

The Cl⁻, Br⁻ and CN⁻ nucleophiles can easily be introduced in the benzene ring of diazonium salts in the presence of Cu(I) ion.

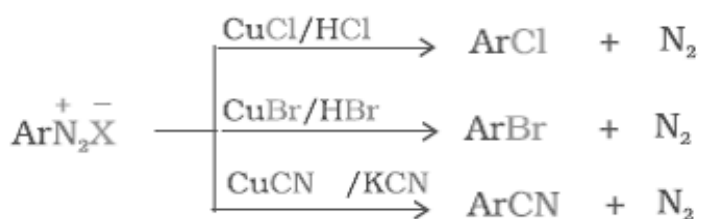

6. Gatterman Reaction

Chlorine or bromine can be introduced in the benzene ring by treating the diazonium salt solution with corresponding halogen acid in the presence of copper powder.

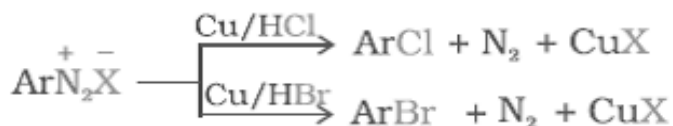

7. Coupling reactions

The azo products obtained have an extended conjugate system having both the aromatic rings joined through the -N=N- bond. These compounds are often coloured and are used as dyes. Benzene diazonium chloride reacts with phenol in which the phenol molecule at its para position is coupled with the diazonium salt to form p-hydroxyazobenzene. This type of reaction is known as coupling reaction.

Similarly the reaction of diazonium salt with aniline yields p-aminoazobenzene.

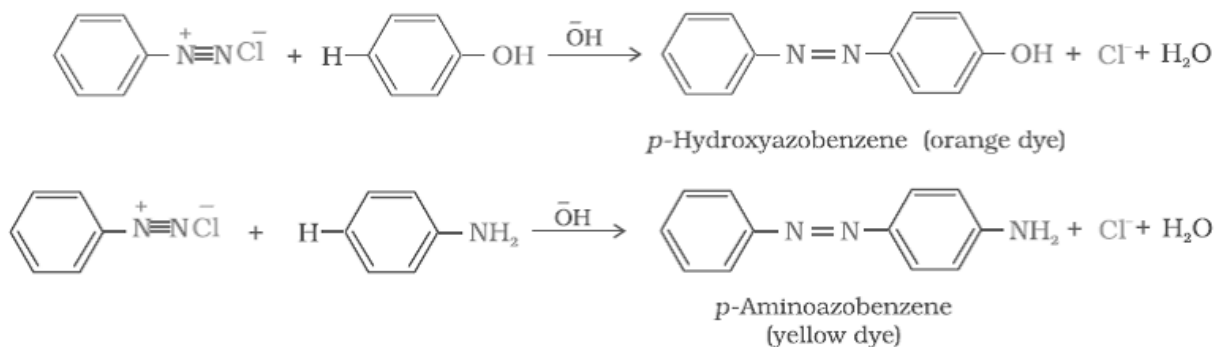

DISTINCTION BETWEEN PAIRS OF COMPOUNDS

Give one chemical test to distinguish between the following pairs of compounds.

- (i) Methylamine and dimethylamine
- (ii) Secondary and tertiary amines
- (iii) Ethylamine and aniline

- (iv) Aniline and benzylamine
 (v) Aniline and N-methylaniline.

ANS. (i) Methylamine and dimethylamine can be distinguished by the carbylamine test. Carbylamine test: Aliphatic and aromatic primary amines on heating with chloroform and ethanolic potassium hydroxide form foul-smelling isocyanides or carbylamines. Methylamine (being an aliphatic primary amine) gives a positive carbylamine test, but dimethylamine does not.

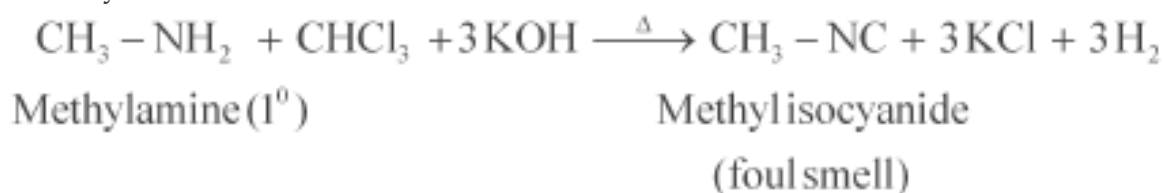

(ii) Secondary and tertiary amines can be distinguished by allowing them to react with Hinsberg's reagent (benzenesulphonyl chloride, $\text{C}_6\text{H}_5\text{SO}_2\text{Cl}$). Secondary amines react with Hinsberg's reagent to form a product that is insoluble in an alkali. For example, N, N-diethylamine reacts with Hinsberg's reagent to form N, N-diethylbenzenesulphonamide, which is insoluble in an alkali. Tertiary amines, however, do not react with Hinsberg's reagent.

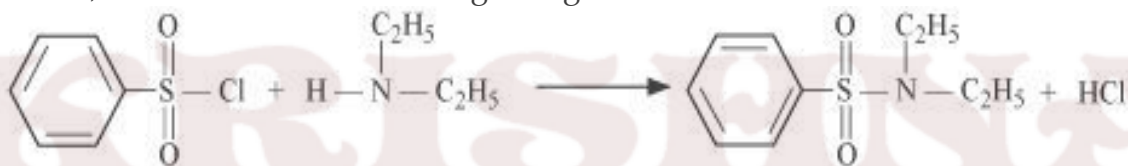

(iii) Ethylamine and aniline can be distinguished using the azo-dye test. A dye is obtained when aromatic amines react with HNO_2 ($\text{NaNO}_2 + \text{dil.HCl}$) at $0-5^\circ\text{C}$, followed by a reaction with the alkaline solution of 2-naphthol. The dye is usually yellow, red, or orange in colour. Aliphatic amines give a brisk effervescence due (to the evolution of N_2 gas) under similar conditions.

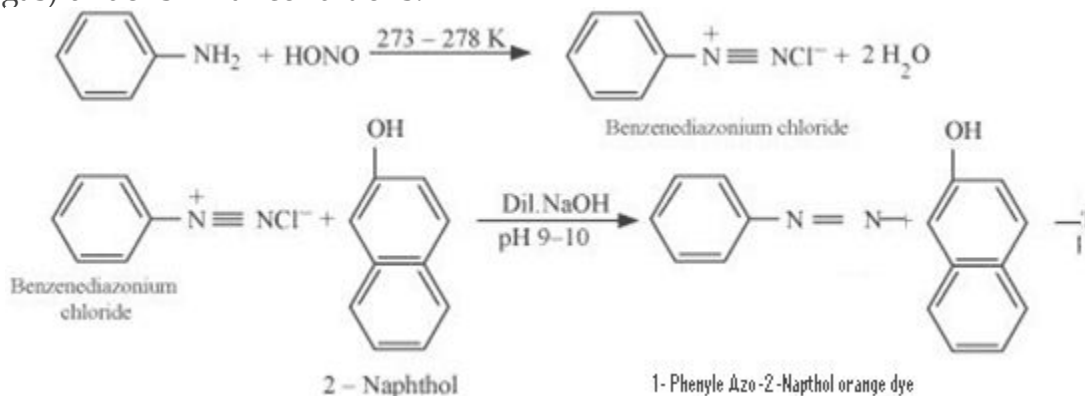

(iv) Aniline and benzylamine can be distinguished by their reactions with the help of nitrous acid, which is prepared in situ from a mineral acid and sodium nitrite.

Benzylamine reacts with nitrous acid to form unstable diazonium salt, which in turn gives alcohol with the evolution of nitrogen gas.

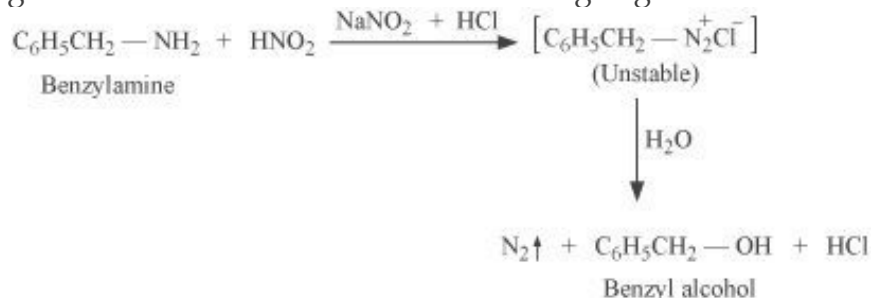

On the other hand, aniline reacts with HNO_2 at a low temperature to form stable diazonium salt. Thus, nitrogen gas is not evolved.

(v) Aniline and N-methylaniline can be distinguished using the Carbylamine test. Primary amines, on heating with chloroform and ethanolic potassium hydroxide, form foul-smelling isocyanides or carbylamines. Aniline, being an aromatic primary amine, gives positive carbylamine test. However, N-methylaniline, being a secondary amine does not.

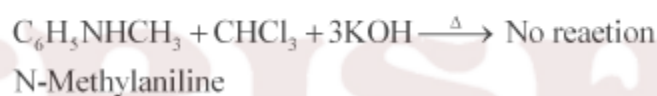
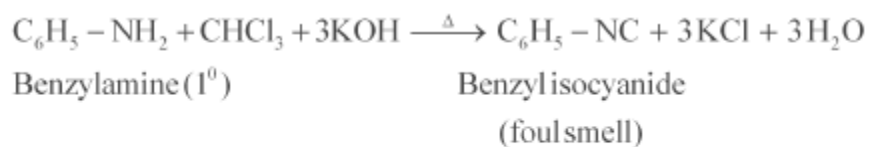

REASONING QUESTIONS

Q1. Account for the following:

- (i) pK_b of aniline is more than that of methylamine.
- (ii) Ethylamine is soluble in water whereas aniline is not.
- (iii) Methylamine in water reacts with ferric chloride to precipitate hydrated ferric oxide.
- (iv) Although amino group is o- and p- directing in aromatic electrophilic substitution reactions, aniline on nitration gives a substantial amount of m-nitroaniline.
- (v) Aniline does not undergo Friedel-Crafts reaction.
- (vi) Diazonium salts of aromatic amines are more stable than those of aliphatic amines.
- (vii) Gabriel phthalimide synthesis is preferred for synthesising primary amines.

ANS. (i) pK_b of aniline is more than that of methylamine:

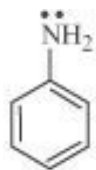

Aniline

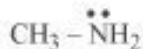

Methylamine

Aniline undergoes resonance and as a result, the electrons on the N-atom are delocalized over the benzene ring. Therefore, the electrons on the N-atom are less available to donate.

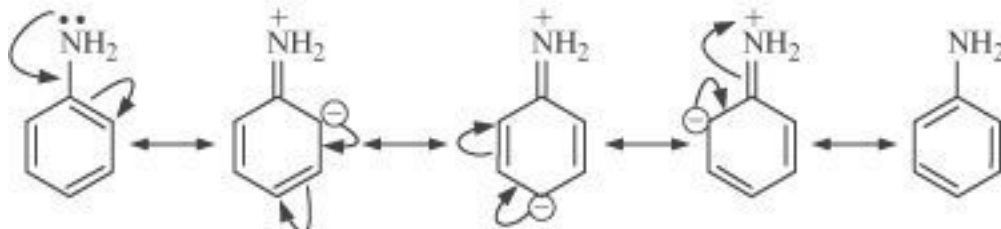

On the other hand, in case of methylamine (due to the +I effect of methyl group), the electron density on the N-atom is increased. As a result, aniline is less basic than methylamine. Thus, pK_b of aniline is more than that of methylamine.

(ii) Ethylamine is soluble in water whereas aniline is not:

Ethylamine when added to water forms intermolecular H-bonds with water. Hence, it is soluble in water.

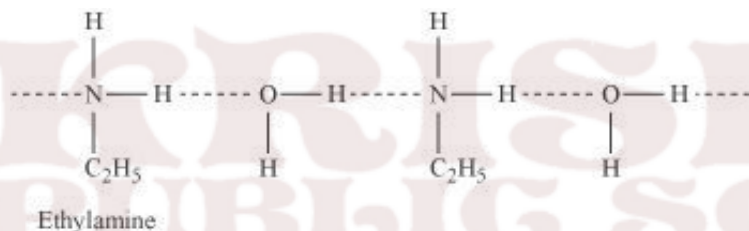

But aniline does not undergo H-bonding with water to a very large extent due to the presence of a large hydrophobic $-\text{C}_6\text{H}_5$ group. Hence, aniline is insoluble in water.

(iii) Methylamine in water reacts with ferric chloride to precipitate hydrated ferric oxide:

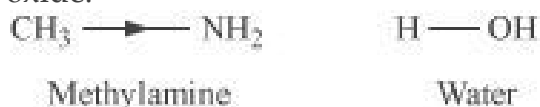

Due to the +I effect of $-\text{CH}_3$ group, methylamine is more basic than water. Therefore, in water, methylamine produces OH^- ions by accepting H^+ ions from water.



Ferric chloride (FeCl_3) dissociates in water to form Fe^{3+} and Cl^- ions.

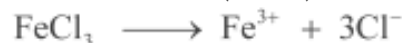

Then, OH^- ion reacts with Fe^{3+} ion to form a precipitate of hydrated ferric oxide.

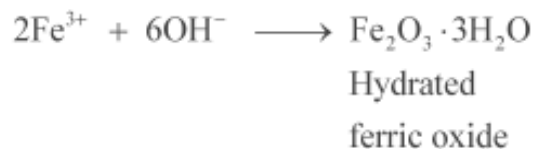

(iv) Although amino group is o,p- directing in aromatic electrophilic substitution reactions, aniline on nitration gives a substantial amount of m-nitroaniline:

Nitration is carried out in an acidic medium. In an acidic medium, aniline is protonated to give anilinium ion (which is meta-directing).



For this reason, aniline on nitration gives a substantial amount of *m*-nitroaniline.

(v) Aniline does not undergo Friedel-Crafts reaction:

A Friedel-Crafts reaction is carried out in the presence of AlCl_3 . But AlCl_3 is acidic in nature, while aniline is a strong base. Thus, aniline reacts with AlCl_3 to form a salt (as shown in the following equation).

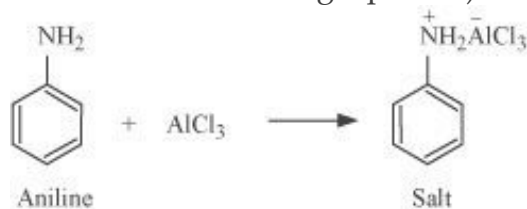

Due to the positive charge on the N-atom, electrophilic substitution in the benzene ring is deactivated. Hence, aniline does not undergo the Friedel-Crafts reaction.

(vi) Diazonium salts of aromatic amines are more stable than those of aliphatic amines:

The diazonium ion undergoes resonance as shown below:

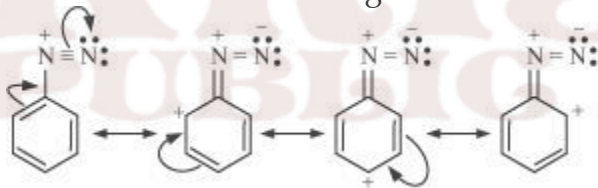

This resonance accounts for the stability of the diazonium ion. Hence, diazonium salts of aromatic amines are more stable than those of aliphatic amines.

(vii) Gabriel phthalimide synthesis is preferred for synthesising primary amines:

Gabriel phthalimide synthesis results in the formation of 1° amine only. 2° or 3° amines are not formed in this synthesis. Thus, a pure 1° amine can be obtained. Therefore, Gabriel phthalimide synthesis is preferred for synthesizing primary amines.

Q2. Why cannot aromatic primary amines be prepared by Gabriel phthalimide

synthesis?

ANS. Gabriel phthalimide synthesis is used for the preparation of aliphatic primary amines. It involves nucleophilic substitution ($\text{S}_{\text{N}}2$) of alkyl halides by the anion formed by the phthalimide.

But aryl halides do not undergo nucleophilic substitution with the anion formed by the phthalimide.

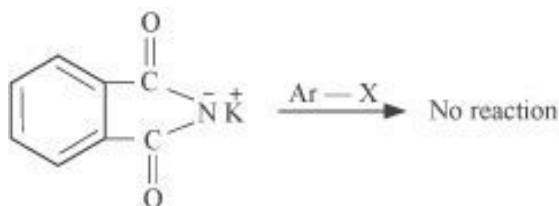

Hence, aromatic primary amines cannot be prepared by this process.

Q3. Give plausible explanation for each of the following:

(i) Why are amines less acidic than alcohols of comparable molecular masses?

(ii) Why do primary amines have higher boiling point than tertiary amines?

(iii) Why are aliphatic amines stronger bases than aromatic amines?

ANS. (i) Amines undergo protonation to give amide ion.

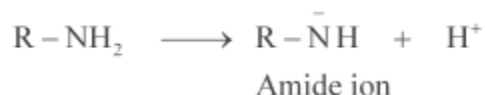

Similarly, alcohol loses a proton to give alkoxide ion.

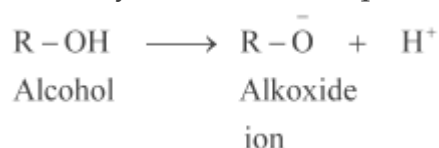

In an amide ion, the negative charge is on the N-atom whereas in alkoxide ion, the negative charge is on the O-atom. Since O is more electronegative than N, O can accommodate the negative charge more easily than N. As a result, the amide ion is less stable than the alkoxide ion. Hence, amines are less acidic than alcohols of comparable molecular masses.

(ii) In a molecule of tertiary amine, there are no H-atoms whereas in primary amines, two hydrogen atoms are present. Due to the presence of H-atoms, primary amines undergo extensive intermolecular H-bonding.

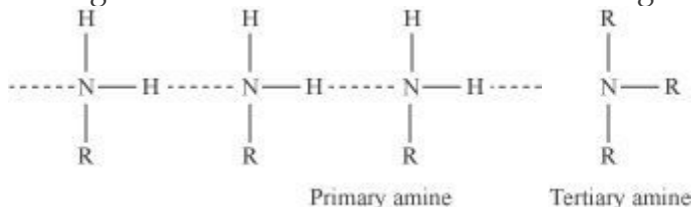

As a result, extra energy is required to separate the molecules of primary amines. Hence, primary amines have higher boiling points than tertiary amines.

(iii) Due to the $-R$ effect of the benzene ring, the electrons on the N-atom are less available in case of aromatic amines. Therefore, the electrons on the N-atom in aromatic amines cannot be donated easily. This explains why aliphatic amines are stronger bases than aromatic amines.

SOLVED QUESTIONS

1 MARK QUESTIONS

Q1. Give the IUPAC name of the compound and classify into primary, secondary or tertiary amines.

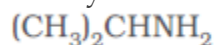

1-Methylethanamine (1^0 amine)

Q2. Give the IUPAC name of the compound and classify into primary, secondary or tertiary amines.

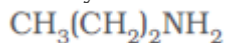

Propan-1-amine (1° amine)

Q3. Give the IUPAC name of the compound and classify into primary, secondary or tertiary amines.



N-Methyl-2-methylethanamine (2° amine)

Q4. Give the IUPAC name of the compound and classify into primary, secondary or tertiary amines.

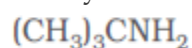

2-Methylpropan-2-amine (1° amine)

Q5. Give the IUPAC name of the compound and classify into primary, secondary or tertiary amines.

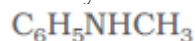

N-Methylbenzamine or N-methylaniline (2° amine)

Q6. Write short notes on diazotization

Aromatic primary amines react with nitrous acid (prepared in situ from NaNO_2 and a mineral acid such as HCl) at low temperatures (273-278 K) to form diazonium salts. This conversion of aromatic primary amines into diazonium salts is known as diazotization. For example, on treatment with NaNO_2 and HCl at 273–278 K, aniline produces benzenediazonium chloride, with NaCl and H_2O as by-products.



Q7. Write short notes on ammonolysis

When an alkyl or benzyl halide is allowed to react with an ethanolic solution of ammonia, it undergoes nucleophilic substitution reaction in which the halogen atom is replaced by an amino ($-\text{NH}_2$) group. This process of cleavage of the carbon-halogen bond is known as ammonolysis.

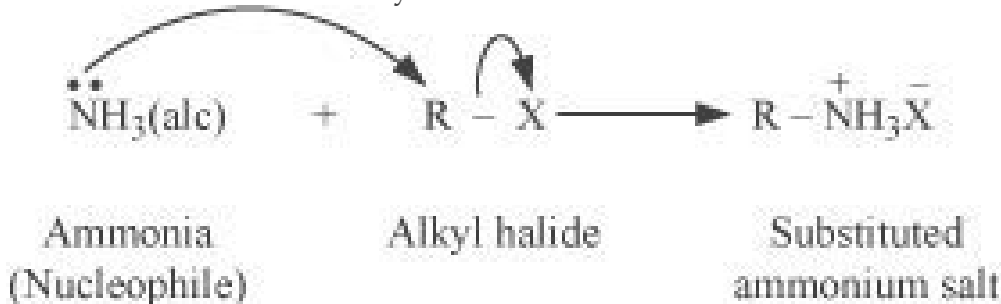

When this substituted ammonium salt is treated with a strong base such as sodium hydroxide, amine is obtained.

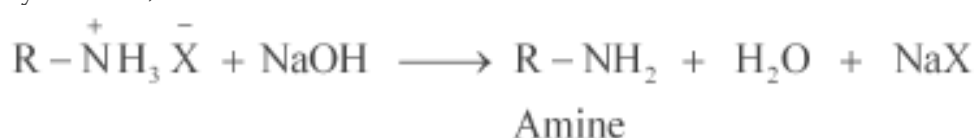

Though primary amine is produced as the major product, this process produces a mixture of primary, secondary and tertiary amines, and also a quaternary ammonium salt

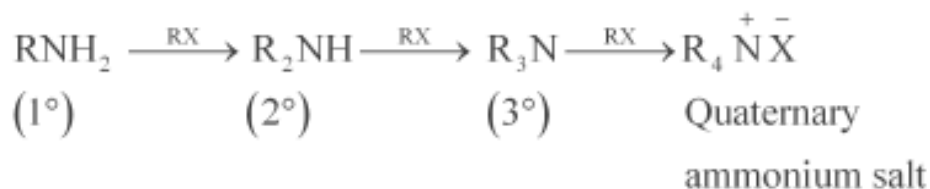

Q8. Write short notes on acetylation.

Acetylation (or ethanoylation) is the process of introducing an acetyl group into a molecule. Aliphatic and aromatic primary and secondary amines undergo acetylation reaction by nucleophilic substitution when treated with acid chlorides, anhydrides or esters. This reaction involves the replacement of the hydrogen atom of $-\text{NH}_2$ or $> \text{NH}$ group by the acetyl group, which in turn leads to the production of amides. To shift the equilibrium to the right hand side, the HCl formed during the reaction is removed as soon as it is formed. This reaction is carried out in the presence of a base (such as pyridine) which is stronger than the amine.

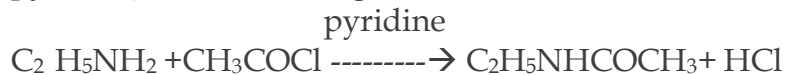

Q9. Why are amines basic in character?

ANS. Like ammonia, the nitrogen atom in amines RNH_2 is trivalent and bears an unshared pair of electrons. Thus it acts like a Lewis base and donates the pair of electrons to electron-deficient species which further increases due to +I effect of alkyl radical.

Q10. Arrange the following in decreasing order of their basic strength:



The decreasing order of basic strength of the above amines and ammonia

follows the following order:

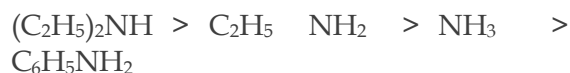

SOLVED EXAMPLES (2 Marks)

Q1. Write chemical equations for the following reactions:

(i) Reaction of ethanolic NH_3 with $\text{C}_2\text{H}_5\text{Cl}$.

(ii) Ammonolysis of benzyl chloride and reaction of amine so formed

with two moles of CH_3Cl

ANS.

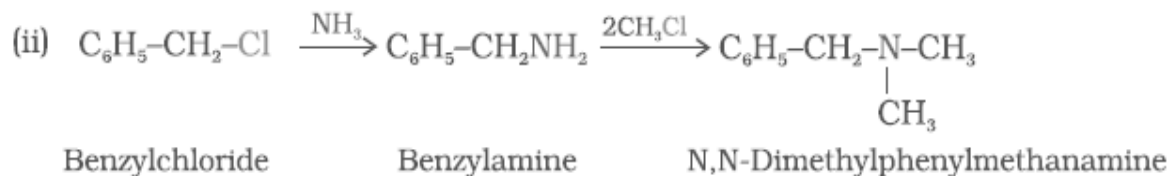
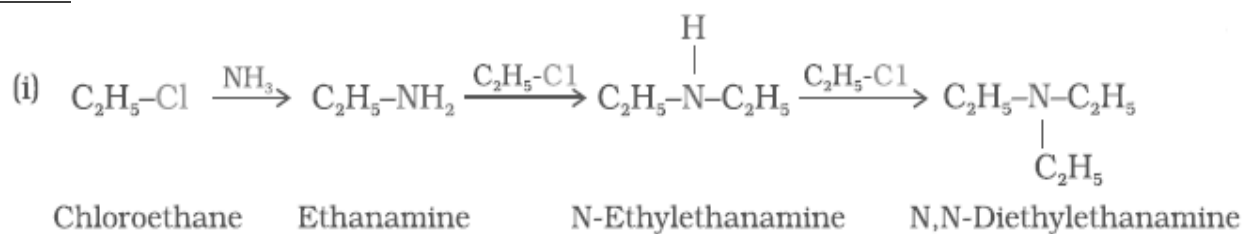

Q2. Write chemical equations for the following conversions:

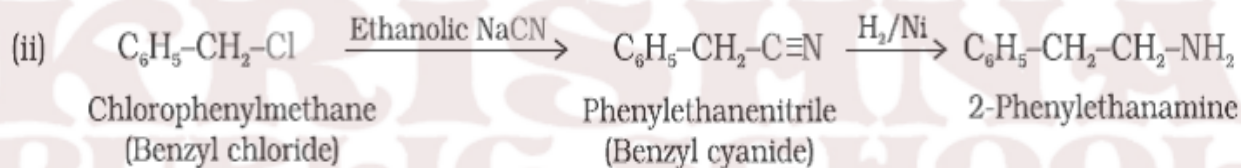
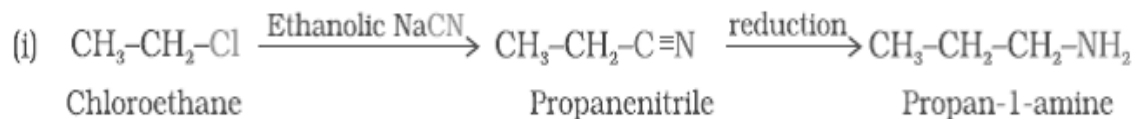

Q3. Write structures and IUPAC names of

(i) the amide which gives propanamine by Hoffmann bromamide reaction.

(ii) the amine produced by the Hoffmann degradation of benzamide.

ANS. (i) Propanamine contains three carbons. Hence, the amide molecule must contain four carbon atoms. Structure and IUPAC name of the starting amide with four carbon atoms are given below:

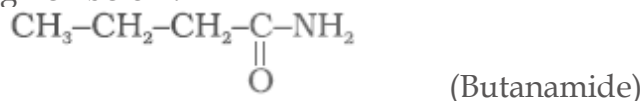

(ii) Benzamide is an aromatic amide containing seven carbon atoms. Hence, the amine formed from benzamide is aromatic primary amine containing six carbon atoms.

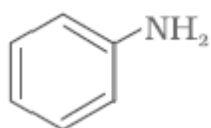

(Aniline or benzenamine)

Q4. How will you convert 4-nitrotoluene to 2-bromobenzoic acid?

ANS.

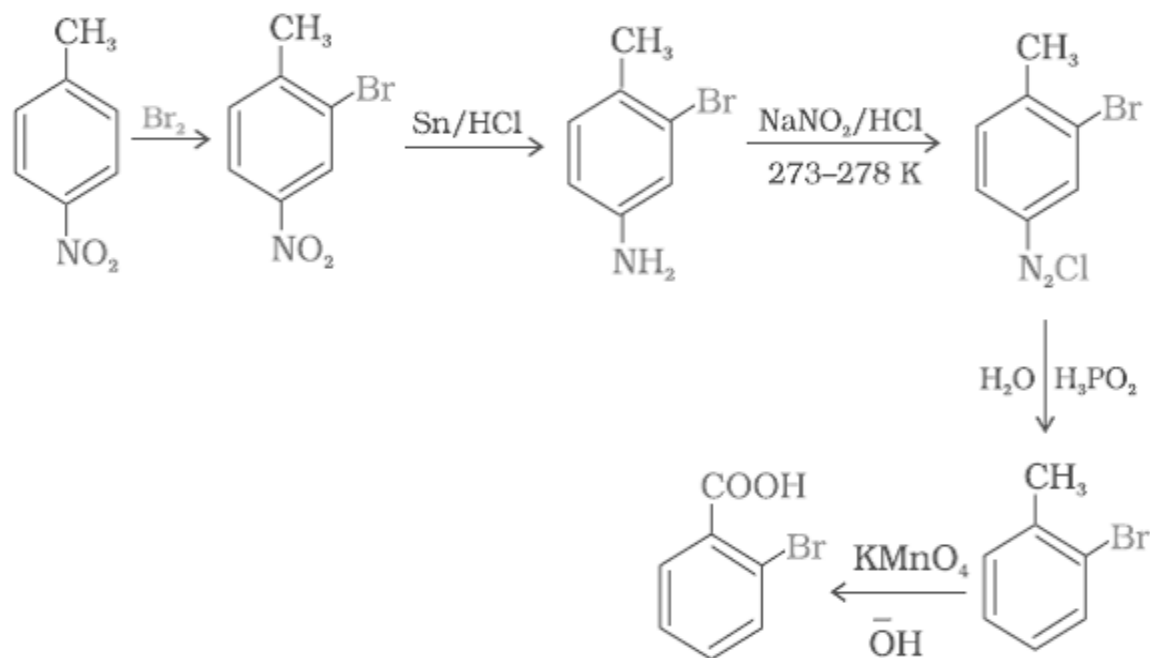

Q5. Write the reactions of (i) aromatic and (ii) aliphatic primary amines with nitrous acid.

ANS. (i) Aromatic amines react with nitrous acid (prepared in situ from NaNO_2 and a mineral acid such as HCl) at $273 - 278\text{ K}$ to form stable aromatic diazonium salts i.e., NaCl and $2\text{H}_2\text{O}$.

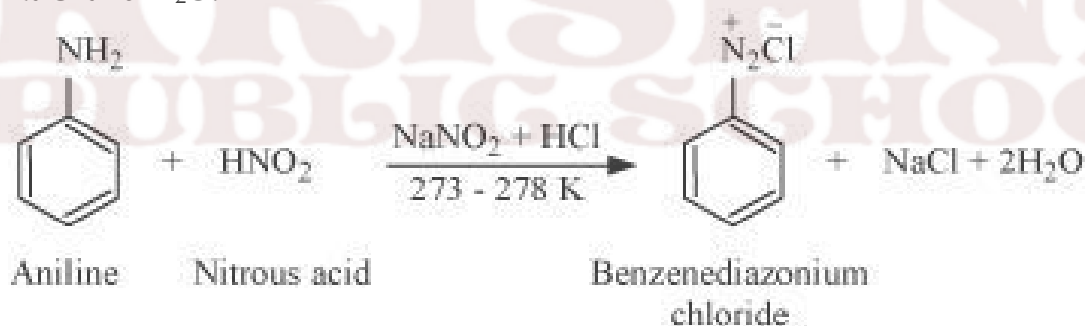

(ii) Aliphatic primary amines react with nitrous acid (prepared in situ from NaNO_2 and a mineral acid such as HCl) to form unstable aliphatic diazonium salts, which further produce alcohol and HCl with the evolution of N_2 gas.

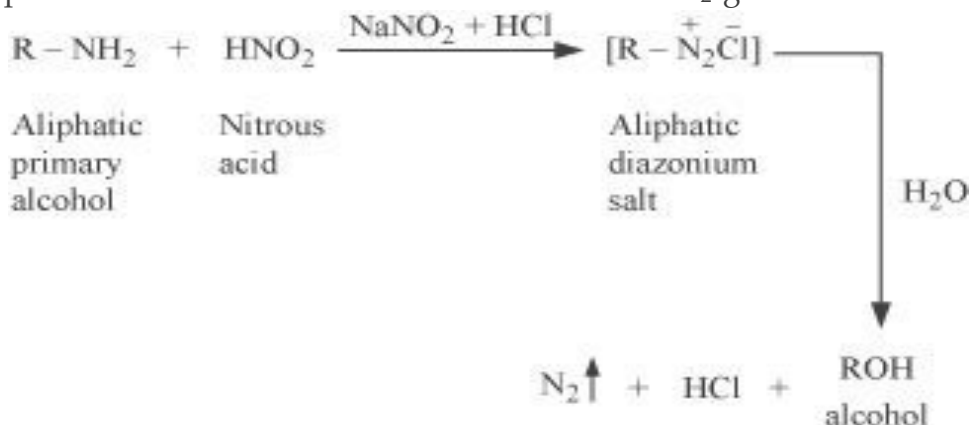

Q6. How will you convert:

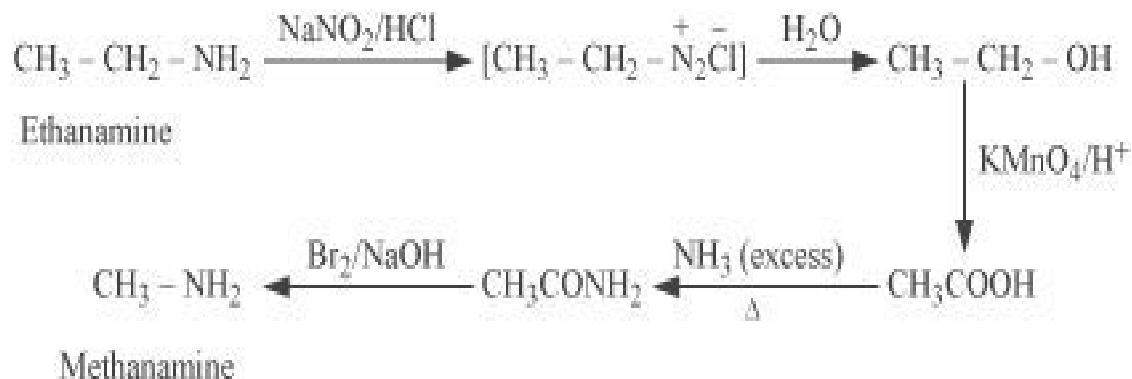

Q8. How will you convert

(i) Ethanoic acid into propanoic acid

(ii) Methanamine into ethanamine

ANS. (i)

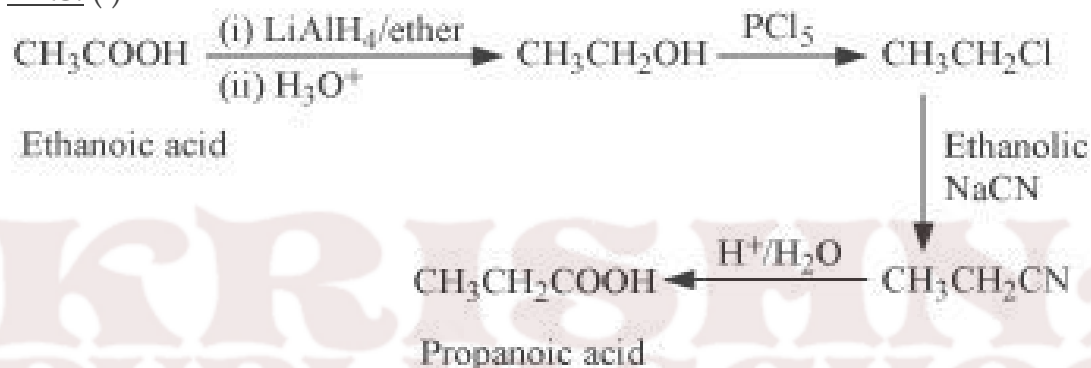

(ii)

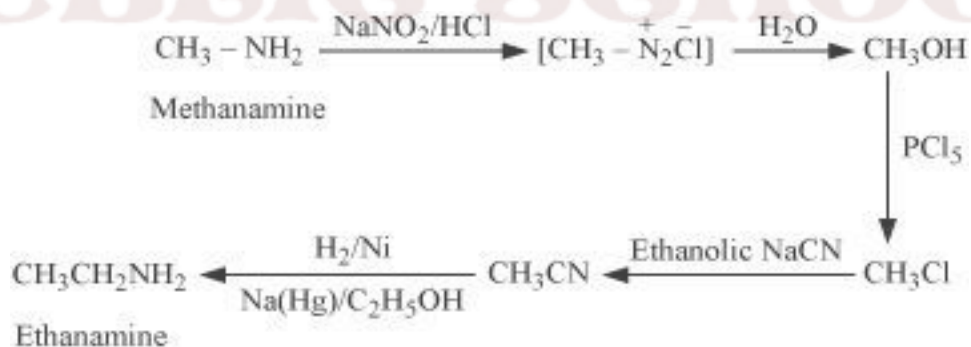

Q9. How will you convert

(i) Nitromethane into dimethylamine

(ii) Propanoic acid into ethanoic acid?

(i)

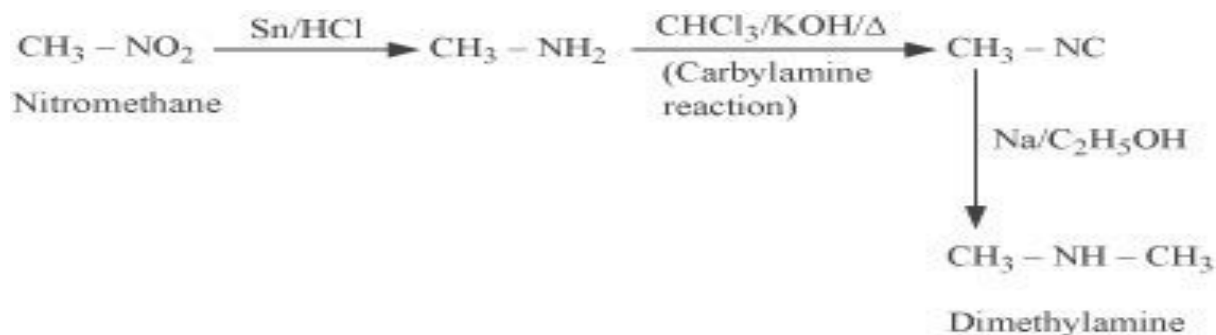

(ii)

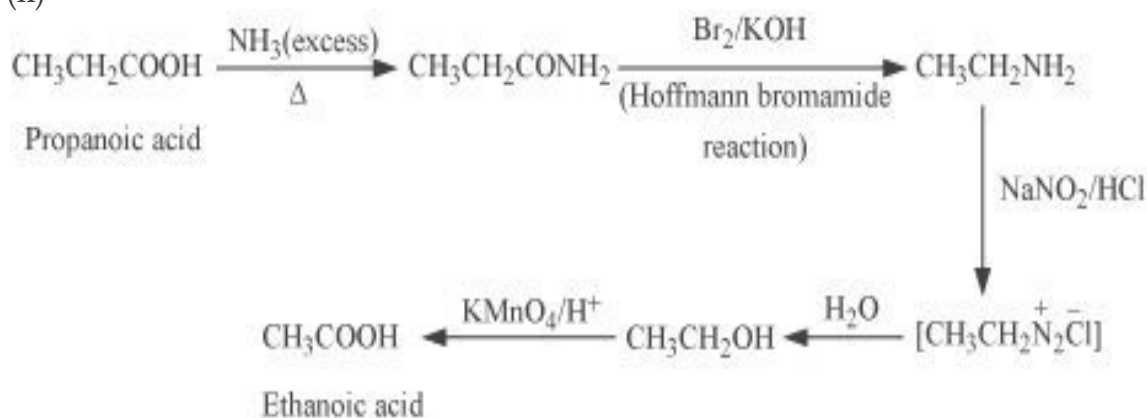

Q10. An aromatic compound 'A' on treatment with aqueous ammonia and heating forms compound 'B' which on heating with Br₂ and KOH forms a compound 'C' of molecular formula C₆H₇N. Write the structures and IUPAC names of compounds A, B and C.

ANS. It is given that compound 'C' having the molecular formula, C₆H₇N is formed by heating compound 'B' with Br₂ and KOH. This is a Hoffmann bromamide degradation reaction. Therefore, compound 'B' is an amide and compound 'C' is an amine. The only amine having the molecular formula, C₆H₇N is aniline, (C₆H₅NH₂). The given reactions can be explained with the help of the following equations:

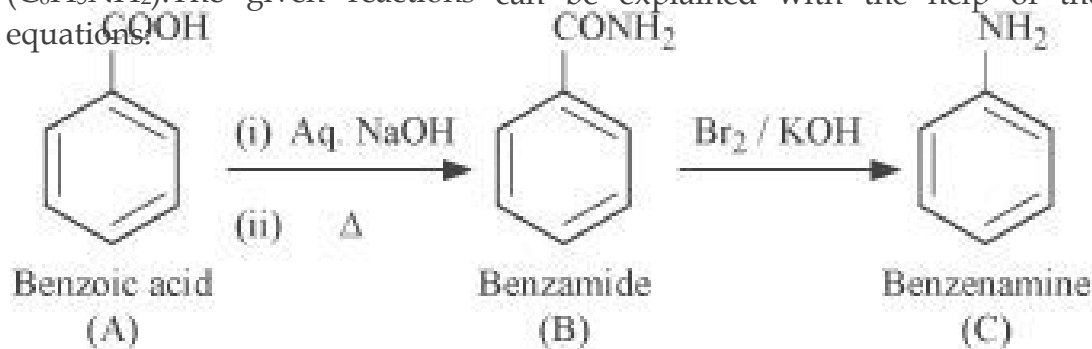

3 MARKS QUESTIONS

Q1. Arrange the following:

- (i) In decreasing order of the pK_b values:
 C₂H₅ NH₂, C₆H₅NHCH₃, (C₂H₅)₂ NH and C₆H₅NH₂

(ii) In increasing order of basic strength:

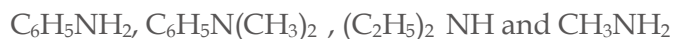

(iii) In increasing order of basic strength:

Aniline, p-nitroaniline and p-toluidine

ANS. (i) The order of increasing basicity of the given compounds is as follows:

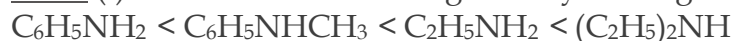

We know that the higher the basic strength, the lower is the pK_b values.

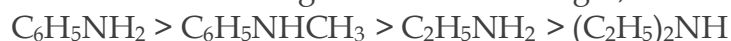

(ii) The increasing order of the basic strengths of the given compounds is as follows:

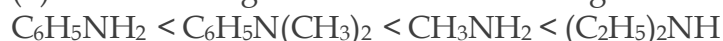

(iii) The increasing order of the basic strengths of the given compounds is :

p-Nitroaniline < Aniline < p-Toluidine

Q2. Arrange the following

(i) In decreasing order of basic strength in gas phase:



(ii) In increasing order of boiling point:

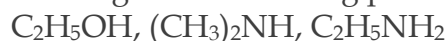

(iii) In increasing order of solubility in water:

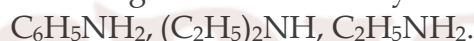

ANS. (i) The given compounds can be arranged in the decreasing order of their basic strengths in the gas phase as follows:



(ii) The given compounds can be arranged in the increasing order of their boiling points as follows:



(iii) The more extensive the H-bonding, the higher is the solubility. $\text{C}_2\text{H}_5\text{NH}_2$ contains two H-atoms whereas $(\text{C}_2\text{H}_5)_2\text{NH}$ contains only one H-atom. Thus, $\text{C}_2\text{H}_5\text{NH}_2$ undergoes more extensive H-bonding than $(\text{C}_2\text{H}_5)_2\text{NH}$. Hence, the solubility in water of $\text{C}_2\text{H}_5\text{NH}_2$ is more than that of $(\text{C}_2\text{H}_5)_2\text{NH}$.

Q3. Accomplish the following conversions:

(i) Nitrobenzene to benzoic acid

(ii) Benzene to m-bromophenol

(iii) Benzoic acid to aniline

ANS. (i)

ANS. (i)

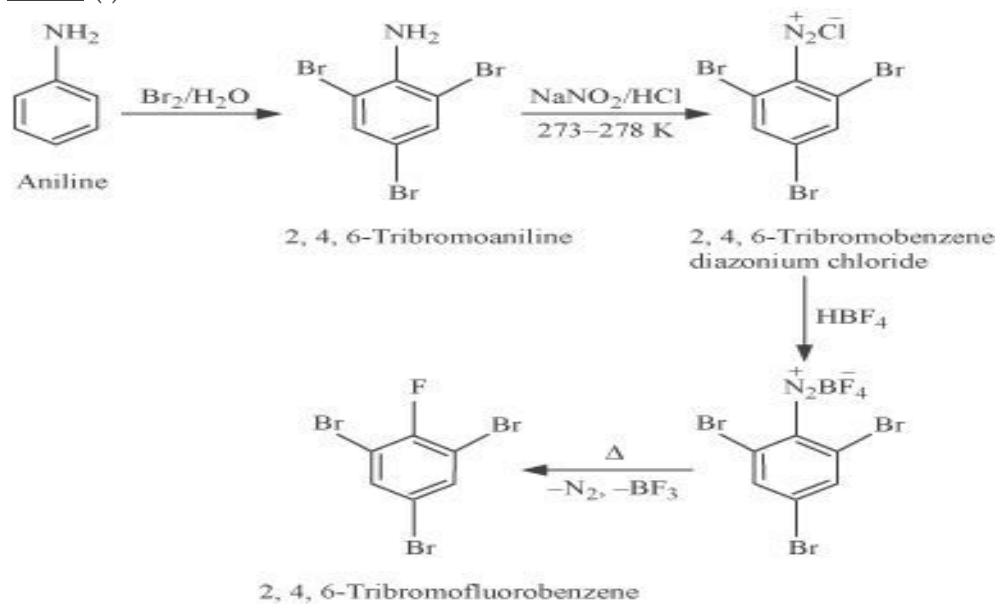

(ii)

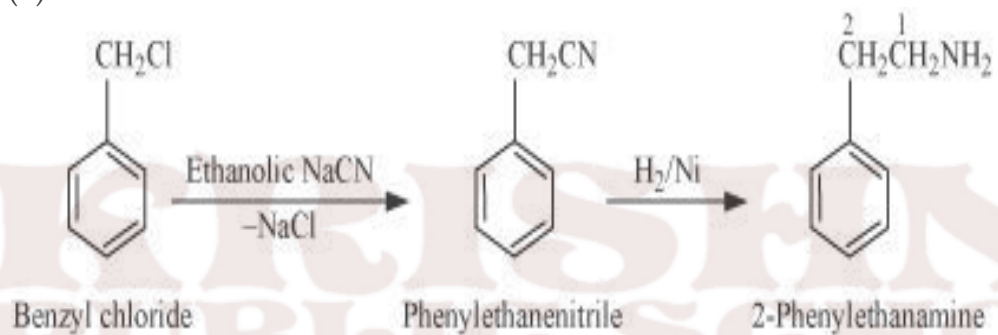

(iii)

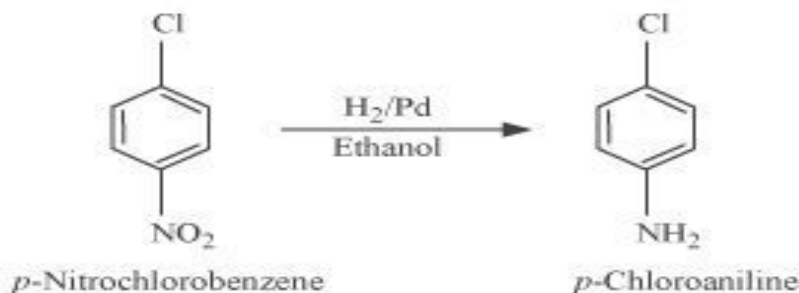

Q5. Accomplish the following conversions:

- (i) Aniline to *p*-bromoaniline
- (ii) Benzamide to toluene
- (iii) Aniline to benzyl alcohol.

ANS. (i)

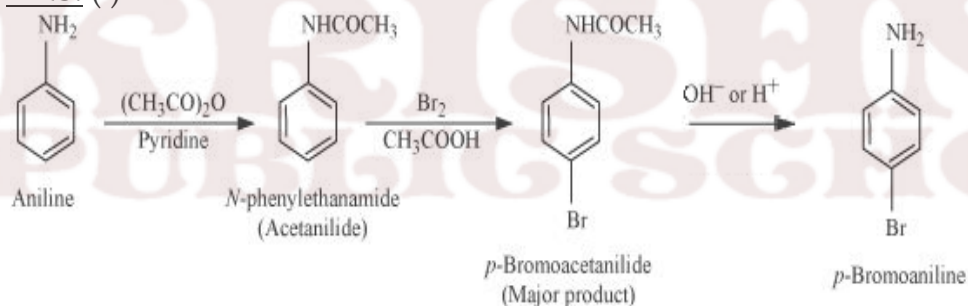

(ii)

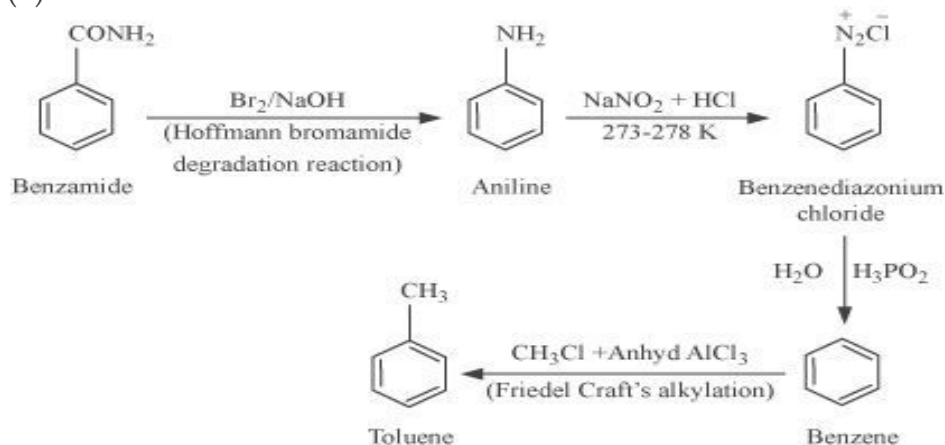

(iii)

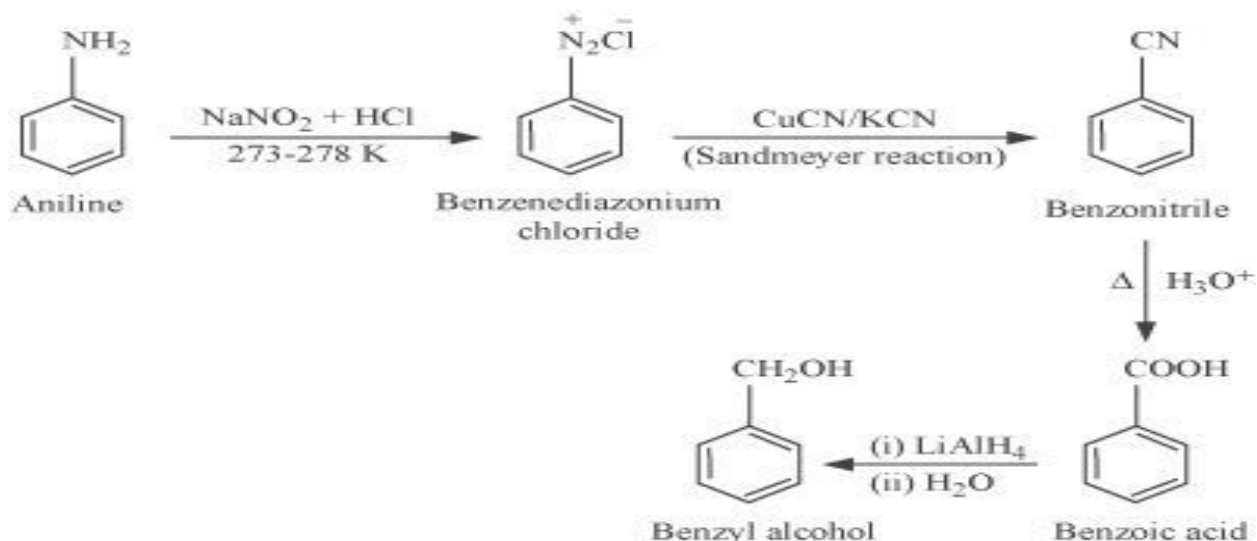

5 MARKS QUESTIONS

Q1. Give the structures of A, B and C in the following reactions:

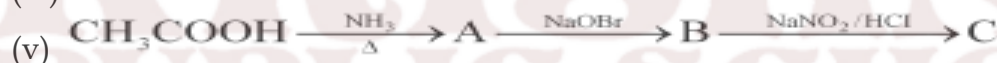

ANS. (i)

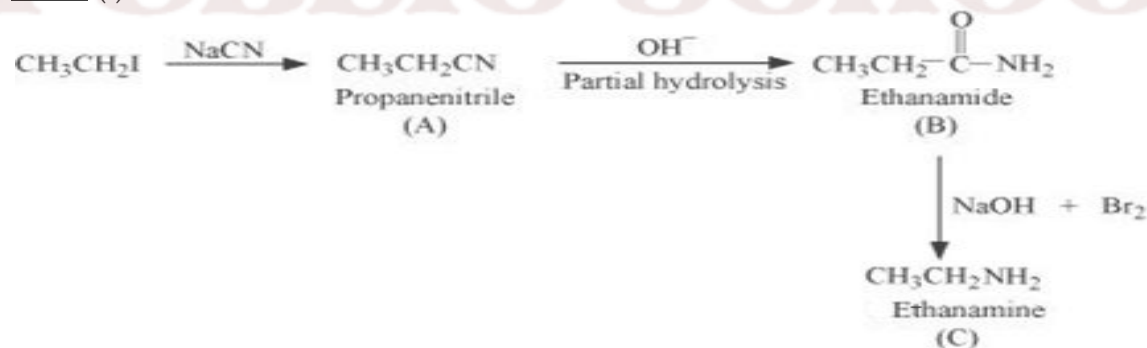

(ii)

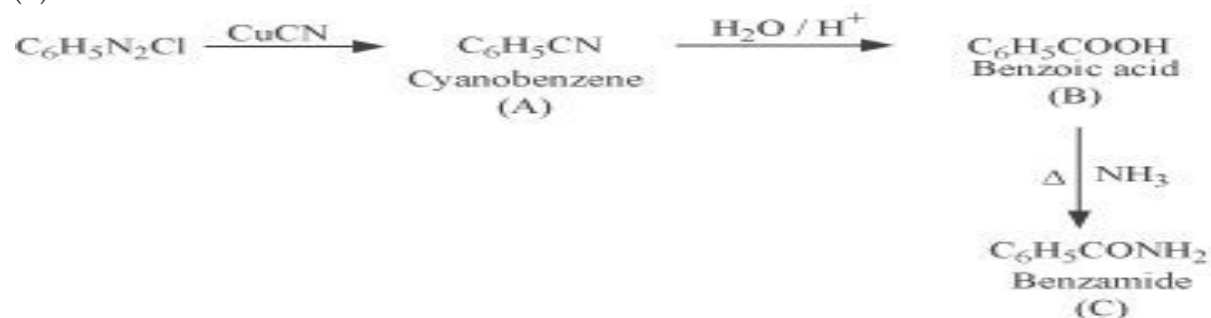

(iii)

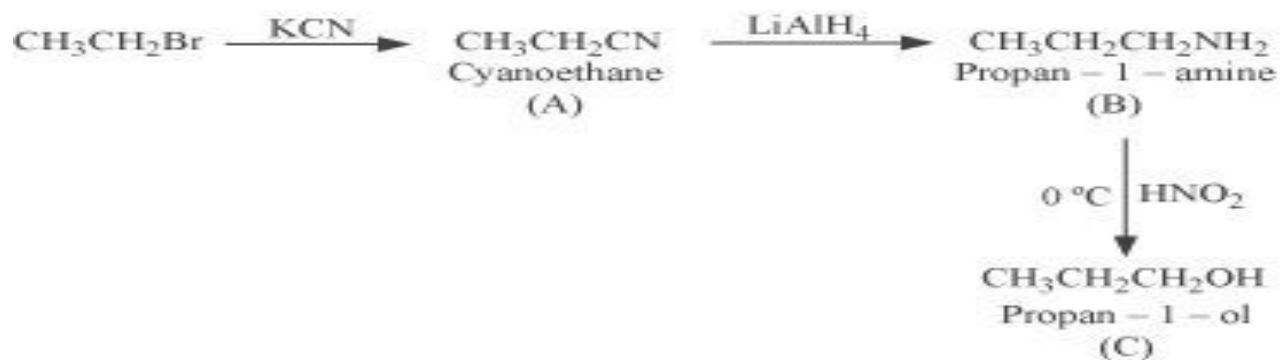

(iv)

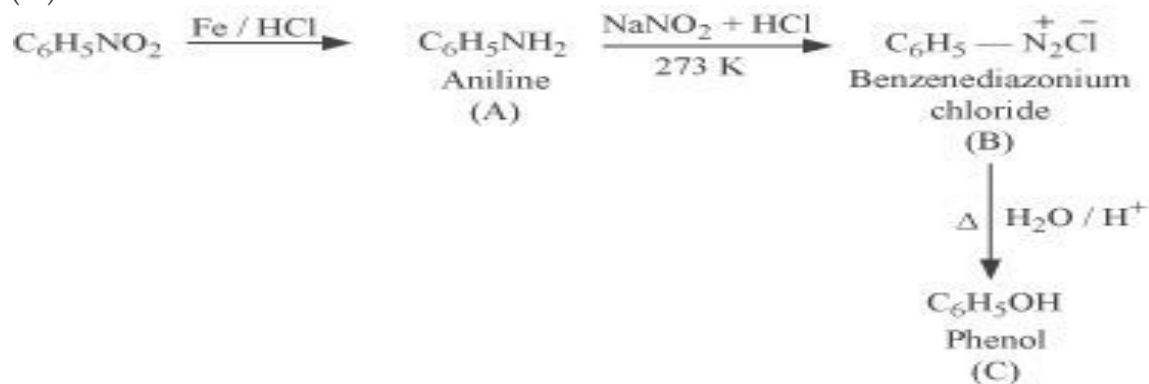

(v)

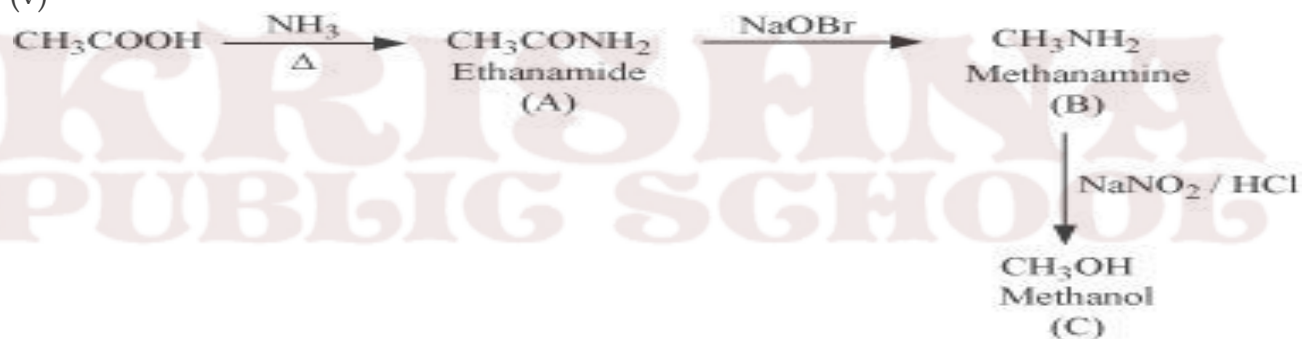

Q2. Complete the following reactions:



ANS. (i)

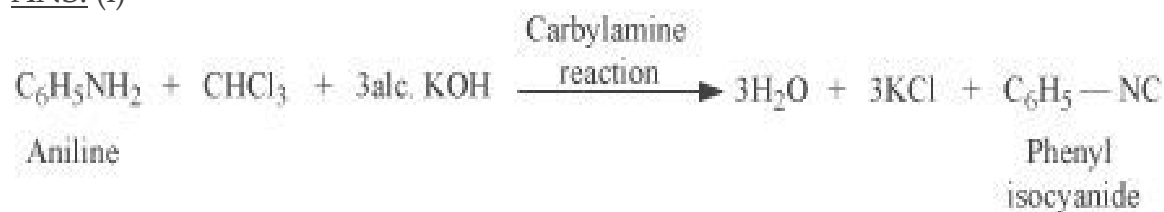

(ii)

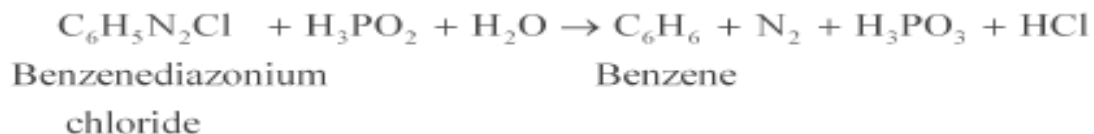

(iii)

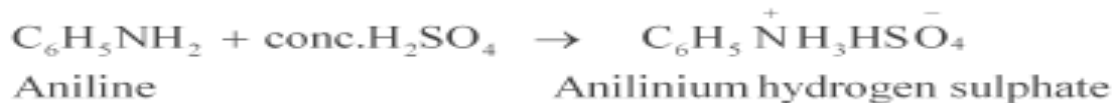

(iv)

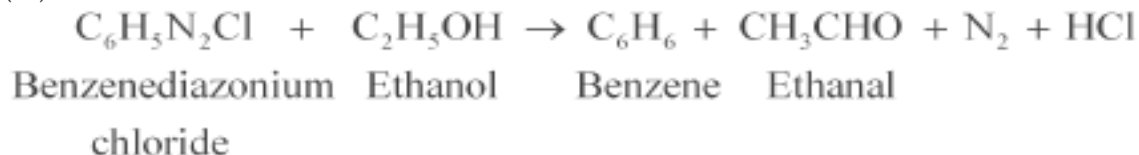

(v)

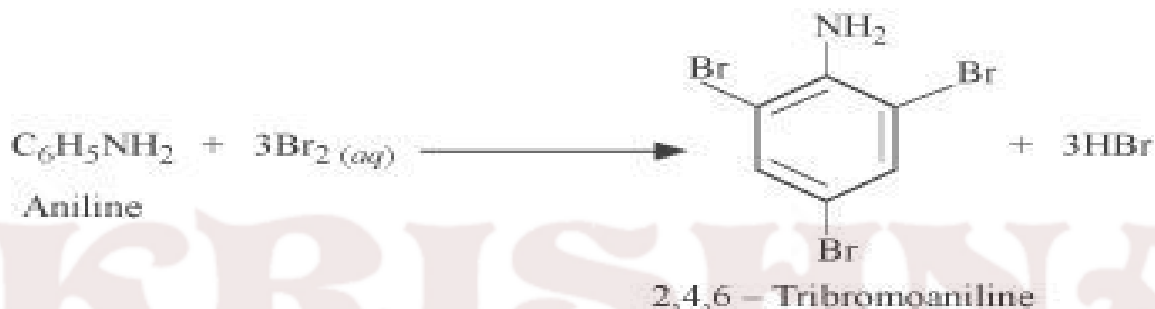

Assignments

Level 1

1. Write IUPAC Name of $\text{C}_6\text{H}_5\text{N}(\text{CH}_3)_3\text{Br}$?
2. Which reaction is used for preparation of pure aliphatic & aralkyl primary amine ?
3. Name one reagent used for the separation of primary, secondary & tertiary amine ?
4. What amine salts are used for determining their molecular masses ?
5. What is the directive influence of amino group in arylamines?
6. Why are benzene diazonium salts soluble in water ?
7. Which is more basic: CH_3NH_2 & $(\text{CH}_3)_3\text{N}$?
8. Which is more acidic, aniline or ammonia ?
9. Write the IUPAC name of $\text{C}_6\text{H}_5\text{NHCH}_3$?
10. Mention two uses of sulphanilic acid?

Level 2

1. What for are quaternary ammonium salts widely used ?
2. What product is formed when aniline is first diazotized and then treated with Phenol in alkaline medium ?
3. How is phenyl hydrazine prepared from aniline ?
4. What is the IUPAC name of a tertiary amine containing one methyl, one ethyl And one n-propyl group ?
5. Explain why silver chloride is soluble in aqueous solution of methylamine ?
6. Write the IUPAC name of $\text{C}_6\text{H}_5\text{N}(\text{CH}_3)_3\text{Br}$?
7. Primary amines have higher boiling points than tertiary amines why ?

- Why is it necessary to maintain the temperature between 273 K & 278 K during diazotization?
- Arrange the following in order of decreasing basic strength : Ethyl amine, Ammonia, Triethylamine ?
- Why aniline is acetylated first to prepare mono bromo derivative?

LEVEL 3

- Arrange the following in decreasing order of their basic strength.
 $C_6H_5NH_2$, $C_2H_5NH_2$, $(C_2H_5)_2NH$, NH_3
- Write chemical equation for the conversion
 CH_3-CH_2-Cl into $CH_3-CH_2-CH_2-NH_2$
- Write the equation involved in Carbylamines reactions?
- How will you distinguish the following pairs? (i) Methanamine and N-methyl methane amine (ii) Aniline and ethyl amine
- Write chemical equations involved in following name reactions. (i) Hoffmann Bromoamide reaction. (ii) Diazotisation reaction.

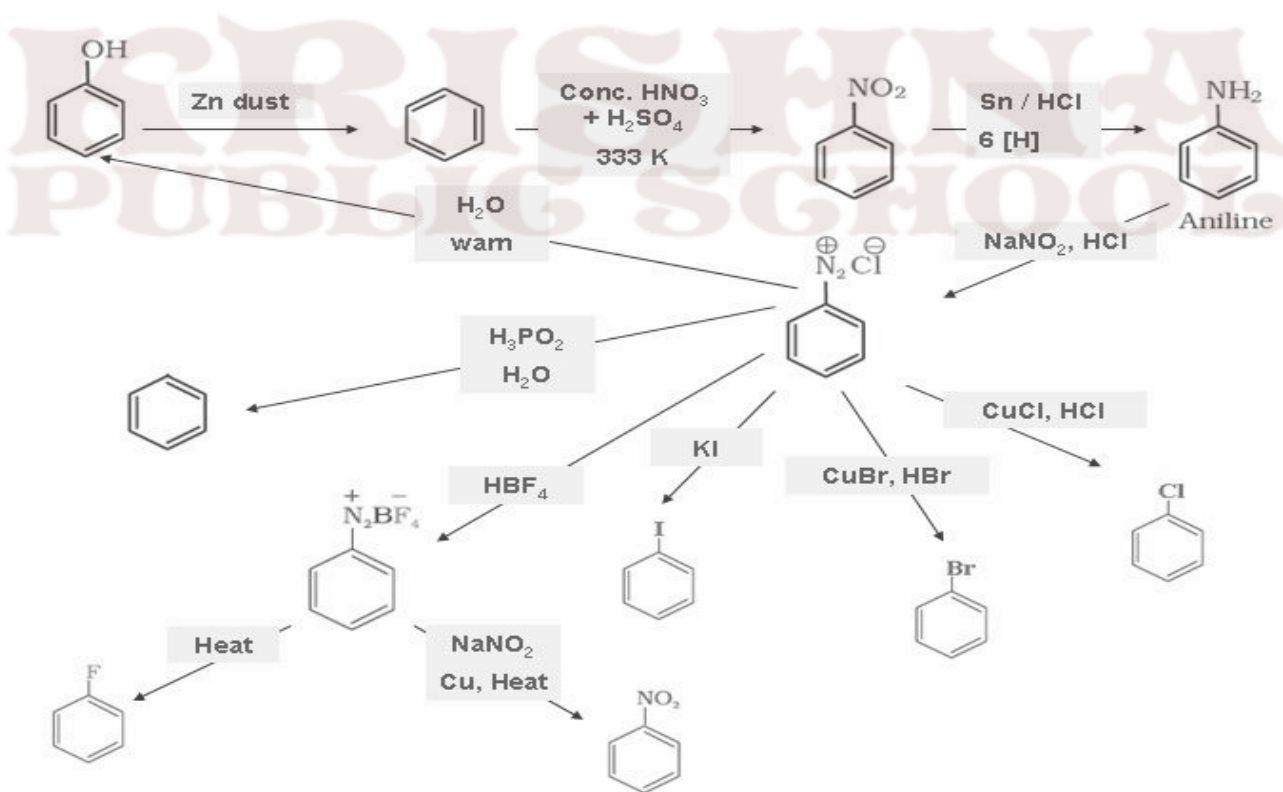

COMMON ERRORS

Basic character of amines in aqueous and in gaseous state, p_{ka} and p_{kb} values

1 MARK QUESTIONS

Q1. Arrange the following in decreasing order of their basic strength:

$C_6H_5NH_2$, $C_2H_5NH_2$, $(C_2H_5)_2NH$, NH_3

Q2. Arrange the following in decreasing order of the pK_b values:

$C_2H_5NH_2$, $C_6H_5NHCH_3$, $(C_2H_5)_2NH$ and $C_6H_5NH_2$

Q3. pK_b of aniline is more than that of methylamine. Why?

Q4. Ethylamine is soluble in water whereas aniline is not. Give reason.

Q5. Methylamine in water reacts with ferric chloride to precipitate hydrated ferric oxide. Why?

Q6. Although amino group is o - and p - directing in aromatic electrophilic substitution reactions, aniline on nitration gives a substantial amount of m -nitroaniline. Give reason.

Q7. Aniline does not undergo Friedel-Crafts reaction. Why?

Q8. Diazonium salts of aromatic amines are more stable than those of aliphatic amines. Why?

Q9. Gabriel phthalimide synthesis is preferred for synthesising primary amines. Give reason

Q10. Why cannot aromatic primary amines be prepared by Gabriel phthalimide synthesis?

Q11. Why do primary amines have higher boiling point than tertiary amines?

Q12. Why are aliphatic amines stronger bases than aromatic amines?

Q13. Direct nitration of aniline is not carried out. Give reason.

Q14. The presence of base is needed in the ammonolysis of alkyl halides. Why?

2 MARKS QUESTIONS

Q1. Write structures and IUPAC names of

(i) the amide which gives propanamine by Hoffmann bromamide reaction.

(ii) the amine produced by the Hoffmann degradation of benzamide.

Q2. Give one chemical test to distinguish between the following pairs of compounds.

(i) Methylamine and dimethylamine (ii) Ethylamine and aniline

Q3. Write short notes on the following:

(i) Carbylamine reaction (ii) Diazotisation

Q4. Explain the following with the help of an example.

(i) Hofmann's bromamide reaction (ii) Coupling reaction

Q5. Explain the following with the help of an example.

(i) Ammonolysis (ii) Gabriel phthalimide synthesis

Q6. How can you convert an amide into an amine having one carbon less than the starting compound? Name the reaction.

Q7. Give a chemical test to distinguish between:

(a) $C_6H_5NH_2$ & CH_3NH_2

(b) CH_3NHCH_3 & $(CH_3)_3N$

Q8. Give the IUPAC names of:

(a) $(CH_3)_2CHNH_2$

(b) $(CH_3CH_2)_2NCH_3$

Q9. Write the structures of:

(a) 3-Bromobenzenamine

(b) 3-Chlorobutanamide

3 MARKS QUESTIONS

Q1. How will you convert

- (i) Benzene into aniline
- (ii) Benzene into N, N-dimethylaniline
- (iii) Aniline to Sulphanilic acid

Q2. An aromatic compound 'A' on treatment with aqueous ammonia and heating forms compound 'B' which on heating with Br₂ and KOH forms a compound 'C' of molecular formula C₆H₇N. Write the structures and IUPAC names of compounds A, B and C.

Q3. How will you carry out the following conversions (Write Chemical equations and reaction conditions):

- (a) Aniline to Phenol
- (b) Acetamide to Ethylamine
- (c) Aniline to *p*-nitroaniline

KRISHNA
PUBLIC SCHOOL

Chapter:-6 General Principles & Process of Isolation of Elements

Important Points :

1. The chemical substances in the earth's crust obtained by mining are called Minerals.
2. Minerals, which act as source for metal, are called Ore.
3. The unwanted impurities present in ore are called Gangue.
4. The entire process of extraction of metal from its ore is called Metallurgy.
5. Removal of gangue from ore is called Concentration, Dressing or Benefaction of ore.
6. Concentration by Hydraulic washing is based on the difference in gravities of ore and gangue particles.
7. Concentration by Magnetic separation is based on differences in magnetic properties of ore components. If either of ore or gangue is capable of attracted by a magnet field, then such separation is carried out.
8. Concentration by Froth Flotation Process is based on the facts that sulphide ore is wetted by oil & gangue particles are wetted by water.
9. Concentration by Leaching is based on the facts that ore is soluble in some suitable reagent & gangue is insoluble in same reagent. e.g. Bauxite ore contains impurities of silica, iron oxide & TiO_2 . The powdered ore is treated with NaOH which dissolve Al & impurities remains insoluble in it.



10. Calcination involves heating of ore in absence of air below melting point of metal. In this process volatile impurities escapes leaving behind metal oxide.



11. Roasting involves heating of ore in presence of air below melting point of metal in reverberatory furnace. In this process volatile impurities escapes leaving behind metal oxide and metal sulphide converts to metal oxide.



12. Reduction of metal oxide involves heating of metal in presence of suitable reagent Coke or CO_2 .

13. Reactions taking place at different zones of blast furnace in extraction of iron:-

(i) Zone of reduction:- Temperature range 250°C-700°C



(ii) Zone of slag formation:- Temperature range 800°C-1000°C



(iii) Zone of fusion: - Temperature range 1150°C-1350°C



(iv) Zone of fusion: - Temperature range 1450°C-1950°C



14. FLOW SHEET FOR EXTRACTION OF IRON:-

Iron ore (Magnetite Fe_3O_4)



Concentration is done by Gravity separation followed by magnetic separation



Calcination & Roasting i.e. Ore + Air + Heat → Moisture, CO_2 , SO_2 , As_2O_3 removed And FeO oxidized to Fe_2O_3



Smelting of charge i.e. mixture of ore, coke & CaCO_3 takes place in long BLAST FURNACE. Following reaction take place at different zones:-

(refer to point 13)



Pig iron is obtained, which is remelted and cooled then cast iron is obtained

15. Pig Iron: - It contains Fe 93-95%, Carbon 2.5-5%, and Impurities 3%.

16. Cast Iron: - It contains Fe 99.5-99.8%, Carbon 0.1-0.2% Impurities 0.3%.

17. Spongy iron: - Iron formed in the zone of reduction of blast furnace is called spongy iron. It contains impurities of C, Mn, Si, etc.

18. FLOW SHEET FOR EXTRACTION OF COPPER:-

Copper Pyrites CuFeS_2



Concentration is done by Froth floatation process

Powdered ore + water + pine oil + air → Sulphide ore in the froth



Roasting is presence of air. following reactions take place:-

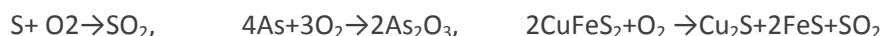

Smelting in small blast furnace of a mixture of Roasted ore, coke, and silica.

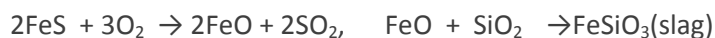

A mixture of Cu_2S , FeS & silica is obtained from blast furnace known as Copper matte



Bessemerisation of copper matte is done in Bessemer converter in presence of air. Following reactions take place:-

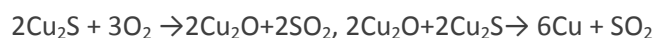
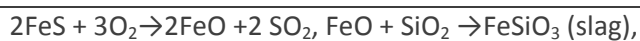

Melted copper is cooled, and then SO_2 is evolved. such copper is known as BLISTER COPPER(98%Cu+2% impurities)

19. FLOW SHEET FOR EXTRACTION OF ALUMINIUM:-

Bauxite $\text{Al}_2\text{O}_3 \cdot 2\text{H}_2\text{O}$



Concentration of ore is done by leaching .Bauxite is treated with NaOH
.Following reaction takes place:-

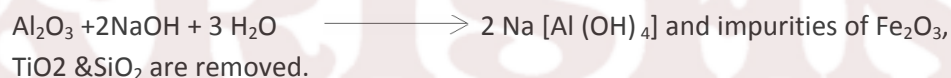

$\text{Na}[\text{Al}(\text{OH})_4]$,then reacts with CO_2 then pure Alumina is obtained.



Electrolytic reduction of pure alumina takes place in iron box (cathode) with cryolite (Na_3AlF_6) & fluorspar CaF_2 . Graphide rods act as anode. Following reactions take place:-



By this process 98.8% pure Aluminum is obtained.

20. Vapour phase refining is used for extraction of Nickel (MOND PROCESS) and Zirconium & Titanium (VAN ARKEL PROCESS).

21. Zone refining is used for extraction of Si, Ge, Ga, etc.

22. Chromatography method is based on selective distribution of various constituents of a mixture between two phases, a stationary phase and a moving phase. The stationary phase can be either solid or liquid on solid support.

22. Column chromatography is based on adsorption phenomenon. This method is useful for those elements, which are available in small amounts and the impurities are not much different in chemical properties from the element to be purified.

VERY SHORT ANSWER TYPE QUESTION

(1 marks)

Q.1- What is slag?

A.1- It is easily fusible material, which is formed when gangue still present in roasted ore combines with the flux.

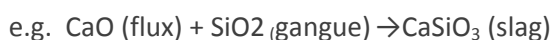

Q.2- Which is better reducing agent at 983K, carbon or CO?

A.2- CO, (above 983K CO being more stable & does not act as a good reducing agent but carbon does.)

Q.3- At which temperature carbon can be used as a reducing agent for FeO ?

A.3- Above 1123K, carbon can reduce FeO to Fe.

Q.4- What is the role of graphite rods in electrometallurgy of aluminium ?

A.4- Graphite rods act as anode, are attacked by oxygen to form CO₂ and so to be replaced time to time.

Q.5- What is the role of cryolite in electrometallurgy of aluminium?

A.5- alumina cannot be fused easily because of high melting point. Dissolving of alumina in cryolite furnishes Al³⁺ ions, which can be electrolyzed easily.

Q.6- What are depressants?

A.6- It is possible to separate two sulphide ore by adjusting proportion of oil to water in froth flotation process by using a substance known as depressant.

e.g. NaCN is used to separate ZnS and PbS.

Q.7- Copper can be extracted by hydrometallurgy but not Zn. Why?

A.7- The E⁰ of Zn is lower than that of Cu thus Zn can displace Cu²⁺ ion from its solution. On other hand side to displace Zn from Zn²⁺ ion, we need a more reactive metal than it.

Q.8- Give name and formula of important ore of iron .

A.8- Haematite – Fe₂O₃, Magnetite –Fe₃O₄, Iron pyrites FeS₂.

Q.9- Give name and formula of important ore of Copper .

A.9- Copper pyrites CuFeS₂, Malachite CuCO₃ . Cu (OH)₂, Cuprite Cu₂O.

Q.10- Give name and formula of important ore of Zinc .

A.10- Zinc blende - ZnS, Calamine- ZnCO₃, Zincite – ZnO .

SHORT ANSWER TYPE QUESTION

(2 marks)

Q.1 Describe the method of refining of nickel.

A.1- In the Mond Process, Ni is heated in a stream of CO forming a volatile complex, which then decomposes at higher temperature to give Ni.



Q.2- What is Zone Refining? Explain with example.

A.2- Zone refining is a method of obtaining a metal in very pure state. It is based on the principal that impurities are more soluble in molten state of metal than solidified state.

In this method, a rod of impure metal is moved slowly over circular heater. The portion of the metal being heated melts & forms the molten zone. As this portion of the rod moves out of heater, it solidified while the impurities pass into molten zone. The process is repeated to obtain ultrapure metal and end of rod containing impure metal cutoff.

Q.3 Write the principal of electro-refining.

A.3- In this method of purification impure metal is made Anode and pure metal is made the cathode. On passing electricity, pure metal is deposited at the cathode while the impurities dissolve in solution as anode mud. E.g. electro-refining of copper:-



Q.4- Write difference between calcinations and roasting .

A.4- Refer points no 10 &11.

Q.5- Describe the method of refining of Zirconium and Titanium.

A.5- Van Arkel process is used for obtaining ultrapure metal. The impure metal is converted into volatile compound, which then decomposes electrically to get pure metal.

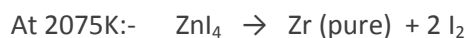

Q.6- Out of C & CO, which is better reducing agent for ZnO?

A.6- Since free energy of formation of CO from C is lower at temperature above 1120K while that of CO₂ from carbon is lower above 1323K than free energy of formation of ZnO. However, the free energy of formation of CO₂ from CO is always higher than that of ZnO. Hence, C is better reducing agent of ZnO.

Q.7- The value of $\Delta_f G^0$ for Cr₂O₃ is -540kJ/mole & that of Al₂O₃ is -827kJ/mole. Is the reduction of Cr₂O₃ possible with aluminium?

A.7- The desired conversion is



It is obtained by addition of following two reactions:-



Therefore, ΔG^0 for desired reaction is $-827+540=-287$, as a result reduction is possible.

Q.8:- Why copper matte is put in silica lined converter?

A.8:- Copper matte consists of Cu₂S and FeS. When blast of air is passed through molten matte in silica-lined converter, FeS present in matte is oxidized to FeO, which combines with silica to form slag.



Q.9- What is meant by term chromatography?

A.9-Chromato means Colour and graphy means writing because the method was first used for separation of coloured substance. It is based on selective distribution of various constituents of a mixture between two phases, a stationary phase and a moving phase. The stationary phase can be either solid or liquid on solid support.

Q.10-Why is reduction of metal oxide easier if metal formed is in liquid state at temperature of reduction.

A.10- The entropy of a substance is higher in liquid state than solid state. In the reduction of metal oxide, the entropy change will be positive if metal formed is in liquid state. Thus, the value of ΔG^0 becomes negative and reduction occurs easily.

SHORT ANSWER TYPE QUESTION

Q.1- Explain the following:-

- (i) Zinc but not copper is used for recovery of Ag from the complex $[\text{Ag}(\text{CN})_2]^-$.
- (ii) Partial roasting of sulphide ore is done in the metallurgy of copper.
- (iii) Extraction of Cu from pyrites is difficult than that from its oxide ore through reduction.

A.1- (i) Zn is more powerful reducing agent in comparison to copper. Zn is also cheaper than Cu.

(ii) Partial roasting of sulphide ore forms some oxide. This oxide then reacts with remaining sulphide ore to give copper i.e. self-reduction occurs.

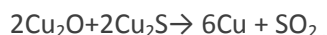
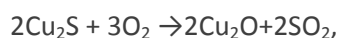

(iii) Though carbon is good reducing agent for oxide but it is poor reducing agent for sulphides. The reduction of metal sulphide does not have large negative value.

Q.2- Explain the method for obtaining pig iron from magnetite.

A.2- Extraction of iron from Magnetite takes place in following steps:-

- (i) Concentration of ore: - It is done by Gravity separation followed by magnetic separation process.
- (ii) Calcination: - It involve heating when the volatile matter escapes leaving behind metal oxide.



(iii) Roasting: - It involves heating of ore in presence of air, thus moisture, CO_2 , SO_2 , As_2O_3 removed And FeO oxidized to Fe_2O_3 .

(iv) Smelting of roasted ore: - A mixture of ore, coke & CaCO_3 is smelted in long BLAST FURNACE. Following reaction takes place at different temperature zones:-

(i) Zone of reduction: - Temperature range 250°C - 700°C



(ii) Zone of slag formation:- Temperature range 800°C - 1000°C



(iii) Zone of fusion:- Temperature range 1150°C-1350°C



(iv) Zone of fusion:- Temperature range 1450°C-1950°C



Thus, Pig iron is obtained from Blast Furnace.

Q.3- Describe the principles of extraction of copper from its ore .

A.3- Refer points no 18. For steps, involve in the extraction.

Q.4- Name the principal ore of aluminium and describe how Al is extracted from its ore.

A.4- Important ores -(i) Bauxite $\text{Al}_2\text{O}_3 \cdot x\text{H}_2\text{O}$ (ii) Corundum Al_2O_3 . Bauxite is commercially important ore Al.

Extraction from Bauxite ore involves the following two stages:-

(i) Purification of bauxite to get pure alumina (Al_2O_3)

(ii) Electrolysis of pure alumina in molten cryolite

Step:-1 Bauxite is treated with NaOH .Following reaction takes place:-

$\text{Al}_2\text{O}_3 + 2\text{NaOH} + 3 \text{H}_2\text{O} \longrightarrow 2 \text{Na} [\text{Al}(\text{OH})_4]$ and impurities of $\text{Fe}_2\text{O}_3, \text{TiO}_2$ & SiO_2 are removed . Na $[\text{Al}(\text{OH})_4]$,then reacts with CO_2 then pure Alumina is obtained.



Step:-2 Electrolytic reduction of pure alumina takes place in iron box (cathode) with cryolite (Na_3AlF_6) & fluorspar CaF_2 . Graphite rods act as anode. Following reactions take place:-

At cathode:- $\text{Al}^{3+} + 3\text{e} \rightarrow \text{Al}$, At Anode:- $2\text{O}^{2-} \rightarrow \text{O}_2 +$
pure Aluminum is obtained.

By this process 98.8%

Q.5- Describe the principles of extraction of Zinc from zinc blende .

A.5- Important ores of Zn:-Zinc blende - ZnS , Calamine- ZnCO_3 , and Zincite – ZnO . ZnS is commercially important ore of Zn. Various stages involved in the extraction of Zn from ZnS are as following:-

(i) Concentration of ore:-It is concentrated by Froth flotation process followed by gravity separation process.

(ii) Roasting:- The concentrated ore is roasted in presence of air. Following reactions take place:-



The mass obtained during roasting is porous and is called porous clinker.

(iii) Reduction of ZnO to Zn: - ZnO is made into bricketts with coke and clay and heated at 1163K. Zn formed distills off and is collected by rapid cooling of zinc vapours.

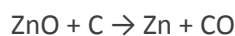

-----END-----

KRISHNA
PUBLIC SCHOOL

Bio molecule

Gist Of The Chapter

1. Carbohydrates- These are optically active polyhydroxy aldehydes or ketones due to presence of chiral 'C' or the compounds which produce these on hydrolysis except dihydroxy acetone is not optically active.

2. Classification-

(i) Monosaccharide's – Those carbohydrates which cannot get hydrolysed e.g. glucose, fructose, galactose etc.

(ii) Oligosaccharides- Those carbohydrates which give two or more monosaccharide's on hydrolysis e.g. sucrose on hydrolysis gives glucose and fructose. Raffinose on hydrolysis gives glucose, fructose and galactose.

(iii) Polysaccharides- Those carbohydrates which on hydrolysis give large number of monosaccharide's hydrolysis. eg starch, cellulose, glycogen.

3. Sugar-

(i) Reducing Sugars- Those which reduce Fehling's or Tollen's reagent. They have free aldehydic groups, eg, glucose, fructose, galactose

(ii) Non Reducing Sugars- Those which do not reduce Fehling's or Tollen's reagent. They do not have free functional group, e.g., sucrose

4. Glucose- It is a monosaccharide's with molecular formula $C_6H_{12}O_6$

5. Preparation

(i) From Sucrose

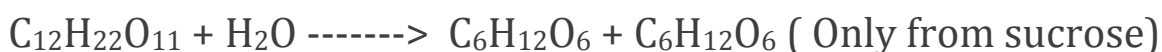

(ii) From Starch



6. Structure

(i) Fischer structure -



(+) Glucose has 'D' configuration as shown

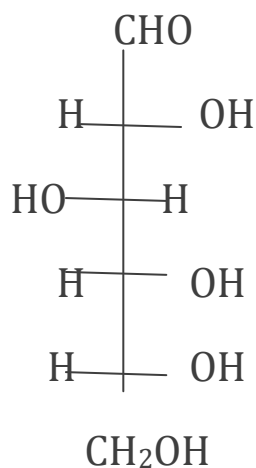

'D' means —OH group on first chiral 'C' from the bottom is on right hand and + means it is dextro rotator, i.e, it rotates plane polarized light towards right.

(ii) Cyclic Structure OF Glucose: the straight chain is unable to explain the following reactions.

(a) It does not give the 2, 4-DNP test, Schiff's Test and does not form the hydrogensulphide product with NaHSO_3 .

(b) The pentacetate of glucose does not react with NH_2OH , indicating the absence of free aldehydic group.

(iii) Glucose exist in 2 different crystalline forms α and β forms. These are called anomers. They differ in optical rotation, they also differ in melting point.

Anomers are isomers which have a different configuration across C-1 (first chiral 'C' atom).

7. Glycosidic Linkage: The linkage between two monosaccharide units through oxygen is called the glycosidic linkage.

8. Proteins: These are micro molecules made up of amino acids joined via a peptide link ($-(\text{-CONH-})-$ is the peptide linkage). These are required for growth and development of the body.

9. Amino Acids: These contain an amino ($-\text{NH}_2$) and an acidic ($-\text{COOH}$) group and are therefore amphoteric in nature. In solution they exist in the form of zwitter ion.

10. Classification

Fibrous Protein	Globular Protein
(i) Polypeptide chains run parallel or anti-parallel and held together by hydrogen and disulphide bonds.	(i) Chains of Polypeptide coil around to give a spherical shape.
(ii) Generally insoluble in water. e.g. Keratin, collagen, myosin, fibroin.	(ii) Usually soluble in water. e.g., insulin, thyroglobin, albumin, haemoglobin and fibrinogen gets converted into fibrous protein fibroin on clotting of blood.

11. Structure And Shape of Protein

Primary Structure	Secondary Structure	Tertiary Structure	Quaternary Structure
The specific sequence of amino acids in the polypeptide chain. Change in amino acids sequence changes the protein. They have covalent	It is the shape in which the long polypeptide chain can exist. It is of two types : α - helix and β - pleated. These structures arise due to regular folding of the backbone of the polypeptide chain	Represents overall folding of the polypeptide chain. It gives rise to the fibrous or globular molecular shapes. Forces stabilizing the 2 ^o and 3 ^o structures are	Protein can be composed of two or more polypeptide chains called sub units. The spatial arrangement of these sub units with respect to each other

bonds.	due to H-bonding between the C=O and –NH- groups of the peptide bond.	hydrogen bonds, disulphide linkages, van der waal's and electrostatic forces of attraction.	quaternary structure of the protein.
--------	---	---	--------------------------------------

12. Denaturaion of Protein: The protein in native state, when subjected to a physical change like temperature, pH etc undergoes uncoiling and loses its biological activity. The 2^o and 3^o structures are destroyed, only 1^o structure is retained.

Renaturation of Protein:

Some proteins regain their biological activity by reversible process it is called Renaturation of Proteins. In such a cases, when temperature in pH of a denatured proteins is brought back to conditions in which the native protein is stable, secondary and tertiary structures of proteins are restored to which leads to recovery of biological activity.

13. Enzymes: These are biocatalyst and generally globular proteins e.g., invertase, zymase, phenyl, alaninehydroxylase, urease etc.

14. Vitamins: They are organic compounds required in the diet in small amounts to perform specific biological functions for maintenance of optimum growth and health of the organism. They are classified as follows

(i) Fat Soluble Vitamins: Vitamin A, D, E and K. They are stored in liver and adipose tissues.

(ii) Water Soluble Vitamins: B group vitamins and vitamin C. They need to be supplied regularly in diet as they are excreted in urine and cannot be stored (except vitamin B₁₂) in our body.

Their deficiency causes diseases.

Biotin (Vit H) is however neither fat nor water soluble. Its deficiency leads to loss of hair.

15. Nucleic Acids: These are biomolecules which are long chain polymers of nucleotides. They are:

(i) Deoxyribonucleic acid (DNA)

(ii) Ribonucleic acid (RNA)

They are responsible for protein synthesis and transfer of genetic characteristics to offspring's.

16. Composition of Nucleic Acid:

They are made up of pentose sugar (β -D-2-deoxyribose in DNA and β -D-ribose in RNA), phosphoric acid and a nitrogen containing heterocyclic compound (base).

DNA- Bases present are Adenine(A), Thymine(T), Guanine(G) and Cytosine(C).

RNA- contains Adenine(A), Guanine(G), Cytosine(C) and Uracil(U).

17. Nucleoside: The unit formed by the attachment of a base to the 1'-position of sugar (Base+Sugar).

18. Nucleotide: Nucleoside and phosphoric acid at 5'-position.

Nucleotides are bonded by phosphodiester linkages between 5' and 3' carbon atoms of pentose sugar (Base+ Sugar+ Phosphoric Acid).

19. DNA : has a double helical structure with AT and GC linked together through 2 and 3 hydrogen bonds respectively. It is responsible for transfer of genetic characteristics.

20. RNA: is of three types- messenger RNA(m-RNA), ribosomal RNA(r-RNA) and transfer RNA (t-RNA). RNA helps in protein synthesis.

21. Biological Functions of Nuclei Acid: DNA is chemical basis of hereditary and have the coded message for proteins to be synthesized in the cell. RNA carry out the protein synthesis in the cell.

**KRISHNA
PUBLIC SCHOOL**

Biomolecules

VSA Type Questions – (1 Mark)

Q1 – Which functional groups are present in monosaccharides?

Ans - —OH and —CHO or —OH and >CO

Q2 – Name an aldopentose, aldohexose and ketohexose.

Ans – Ribose, glucose and fructose respectively.

Q3 – What is animal starch?

Ans – Glycogen.

Q4 – Which types of bonds are present in a protein molecule?

Ans – Peptide bonds, hydrogen bonds, sulphide bonds, ionic bonds etc.

Q5 – Which α -helix or β -helix is more stable?

Ans – α -helix is right handed and is more stable due to intermolecular H bonding between first and fourth amino acid.

Q6 – The sequence of bases in one strand of DNA is TACGGACA. What is the sequence of bases of complementary strand of DNA.

Ans – ATGCCTGT.

Q7 – Name the vitamin whose deficiency causes rickets?

Ans – Vitamin D.

Q8 – Name the purines present in DNA.

Ans – Adenine and guanine.

Q9 – Give an example of

(a) water soluble (b) fat soluble is

Ans – (a) Vitamin C (b) Vitamin D.

Q10 – Name a protein which is insoluble in water.

Ans – Veratin.

SAI Type Questions

Q1 – Name polysaccharides that make up starch and what is the difference between them.

Ans – Amylose which is linear polymer of α -glucose and amylopectin which is branched polymer of α -glucose. Amylose is water soluble whereas amylopectin is water insoluble.

Q2 – What are anomers?

Ans – Monosaccharides which differ only in the orientation of the $-OH$ group at C-1.e.g, α -glucose and β -glucose.

Q3 – Where does the water present in the egg go after boiling the egg?

Ans – On boiling during denaturation process water gets adsorbed/absorbed in the denatured proteins.

Q4 – Write two main functions of carbohydrates in plants.

Ans – (i) structural material (ii) reserved food material.

Q5 – What do you understand by glycosidic linkage?

Ans – During condensation of two monosaccharides, a water molecule given out and two monosaccharides get linked together by an oxide or ethereal linkage ($-O-$) called as glycosidic linkage.

Q6 – What are essential and non essential amino acid? Give two examples of each type.

Ans – Essential amino acids are those which are not produced in our body.e.g.,valine,leucine.

Non-essential amino acids are those which are produced by our body.e.g.glycine and alanine.

Q7 – How do you explain the amphoteric behavior of amino acids?

Ans – Amino acids have both acidic as well as basic group and they react both with acids as well as bases,therefore they are amphoteric in nature.

Q8 – What is the difference between a nucleoside and a nucleotide?

Ans - Nucleoside = sugar + base

Nucleotide = sugar + base + phosphoric acid

Q9 – Define (a)Enzymes (b)Antibody

Ans – (a)Enzymes – they are biological catalyst which catalyse biochemical reactions.e.g.,



This reaction is catalysed by the enzyme invertase.

(b)Antibody – they are chemical substances which destroy antigens that cause infections.e.g.,vaccination for typhoid produces antibodies in our body to prevent typhoid.

Q10 – What is invert sugar?

Ans – An equimolar aqueous solution of glucose and fructose is called invert sugar.

SA II Type Questions –

Q1 – Give three differences between DNA and RNA.

Ans –

DNA	RNA
1. it has deoxyribose as sugar.	1.it contains ribose as sugar.
2. it contains thymine along with adenine, cytosine and guanine as bases.	2.it contains uracil in place of thymine with other bases.
3. it is responsible for maintaining heredity traits from generation to generation.	3. it is responsible for protein synthesis.

Q2 – Difference between globular protein and fibrous protein.

Ans –

Globular Protein	Fibrous Protein
1. they form α -helix structure. 2. they are water soluble. 3. they involve H bonding.	1. they have β -pleated structure. 2. they are water insoluble. 3. they have strong intermolecular forces of attraction.

Q3 – Give reactions with support cyclic structure of glucose.

Ans – (a) Glucose does not give 2,4-DNP test, Schiff's test and sodium hydrogen sulphide test.

(b) The pentaacetate of glucose does not react with NH_2OH indicating absence of free $-\text{CHO}$ group.

(c) Glucose exists in two crystalline form α and β .

Q4 – Define with example

(a) Isoelectric point (b) Mutarotation (c) Transcription

Ans –

(a) Isoelectric point – the pH at which there is no net migration of any ion towards electrode. e.g, amino acids have isoelectric point at $\text{pH} = 5.5-6.3$

(b) Mutarotation - it is spontaneous change in optical rotation when an optically active substance is dissolved in water. e.g, α -glucose when dissolved in water changes its optical rotation from 111° to 52.5° .

(c) Transcription – it is process by which m-RNA is generated from DNA. e.g, if DNA has base sequence ATACA then m-RNA has base sequence TATCGT.

Q5 – What happens when glucose reacts with

(a)HI (b) HNO₃ (c)Br₂ water

Ans –

(a)C₆H₁₂O₆ + HI -----> n-hexane C₆H₁₄

(b) C₆H₁₂O₆ + HNO₃ -----> saccharic acid

(c)C₆H₁₂O₆ +Br₂ water -----> gluconic acid

Q6 – Differentiate primary , secondary and tertiary structure of protein.

Ans – -In primary structure specific sequence of amino acid are present joined by covalent bonds.

-secondary structure is responsible for the shape of a protein. α-helix and β-pleated in which polypeptide chains have peptide bonds.

-tertiary structure represents overall folding of polypeptide chain and give rise to the fibrous or globular molecular shape.

Q7. Discuss the specificity and mechanism of enzyme action.

Ans. In case of enzymatic reaction the enzyme is so built that it binds to the substrate in a specific manner. Enzymatic reaction involves following steps (Lock and Key Model)-

Step (i): Binding of substrate(S) to enzyme (E) to form complex



Step (ii): Product formation in complex



Step (iii): Dissociation of enzyme product complex, leaving enzyme unchanged



The specificity of enzyme is due to presence of some specific regions called active site on their surface.

Q8. Mention structural differences between amylopectin and cellulose.

Ans.

Amylopectin	Cellulose
1. It is linear polymer of α -glucose.	1. It is linear polymer of β -glucose.
2. It consists of branched chains of α -glucose.	2. In cellulose, the chains are arranged to form bundles and held together by hydrogen bond between glucose and adjacent strands.

Q9. What deficiency diseases are caused due to lack of vitamins B₁, B₆ and K in human diet.

Ans.

Vitamins	Deficiency Disease
B ₁	Beri beri (loss of appetite)
B ₆	Convulsions
K	Increased blood clotting time

Q10. Glucose or Sucrose are soluble in water but cyclohexane and benzene are insoluble in water. Explain.

Ans. Glucose contains five-OH groups and Sucrose contains eight-OH groups, because of this they form intermolecular hydrogen bonding, so they are soluble in water. But benzene and cyclohexane does not contain -OH groups, hence does not form intermolecular hydrogen bonding, so they are not soluble in water.

HOTS Questions

VSA (1 Mark)

Q1. How many atoms are present in the ring of pyranose structure of glucose?

Ans. 5 Carbon atoms and one Oxygen atom.

Q2. Write the formula of Zwitter ion for Glycine.

Ans.

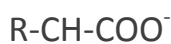

General Formula

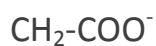

Zwitter ion of glycine

Q3. Which proteins possess α -Helix structure?

Ans. Keratin and myosin possess α -Helix structure.

Q4. What is the native state of protein?

Ans. The energetically most stable shape of the protein at normal pH and temperature is called native state.

Q5. Fresh tomatoes are a better source of Vitamin C than which have been stored for some time. Explain.

Ans. Vitamin C is destroyed on prolonged exposure to air due to its oxidation.

Q6. Why are carbohydrates generally active?

Ans. It is due to the presence of Chiral Carbon atoms in their molecules.

Q7. What type of linkages hold together monomers in DNA?

Ans. Monomers in DNA are linked by phosphate linkages.

Q8. Why is cellulose not digested in human body?

Ans. It is due to the fact that human beings do not have enzymes to digest cellulose.

Q9. Name the enzyme that is used to dissolve blood clots?

Ans. Streptokinase.

Q10. Name two diseases caused due to deficiency of enzymes.

Ans. Albinism and phenylketonuria.

SA Type I (2 Marks)

Q1. Give reasons for the following-

(i) On electrolysis in acidic solution amino acids migrate towards cathode, while in alkaline solution these migrate towards anode.

(ii) The monoamino monocarboxylic acids have two pK_a values.

Ans. (i) In acidic solution, the carboxylate anion accepts a proton and gets converted into a carboxylic group resulting in the formation of a positive ion.

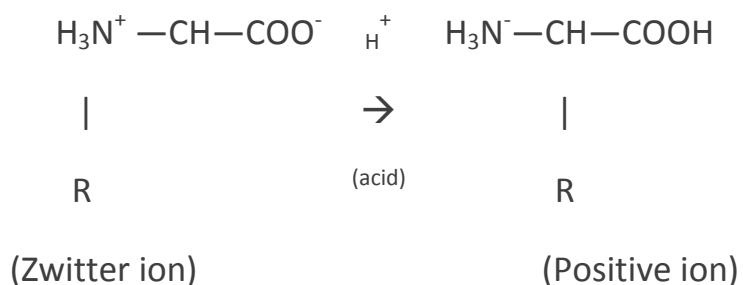

In presence of a base the N^+H_3 ion changes to $-\text{NH}_2$ group by losing a proton and this gives a negative ion.

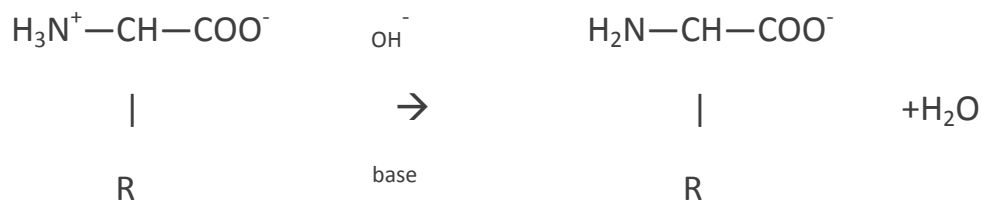

(Zwitter ion)

(Negative ion)

This means that in acidic medium, the amino acid migrates towards the cathode while in alkaline solution it migrates towards anode on electrolysis.

(ii) In aqueous solution, monoamino monocarboxylic amino acid behave like salt at isoelectric point. At a pH lower than isoelectric point (i.e. in acidic medium) it shows one pK_a value which corresponds to structure

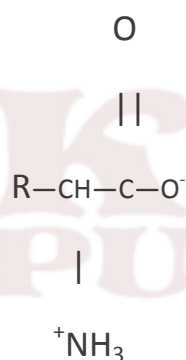

and at a pH higher than isoelectric point, it shows a pK_a value which corresponds to another,

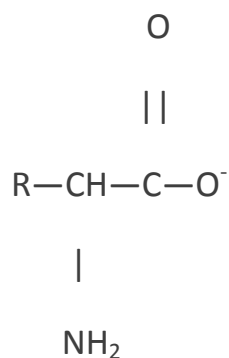

Q2. Which forces are responsible for the stability of α -helix? Why is it named as 3.6₁₃ helix?

Ans. Hydrogen bonds between – N-H and —C=O groups of peptide bonds give stability to the structure.

It is known as 3.6₁₃ helix, since each turn of helix has approximately 3.6 amino acid residue and a 13 member ring is formed by hydrogen bonding.

Q3. Write about the following protein synthesis-

(i) Name the location where the protein synthesis occurs?

Ans. Protein synthesis occurs at the ribosome in cytoplasm.

(ii) How do 64 codones code for only 20 amino acids?

Ans. The 64 codones for 20 amino acids; more than one codon can code for same amino acids, e.g., CUU and CUU both can code leucine. Proline is encoded by CCU, CCA, CCG, and CCC.

Q4. Describe the mechanism of replication of DNA.

Ans. Replication of DNA:- The process by which a DNA molecule produces two identical copies of itself is called replication of DNA. In the DNA double helix the sequence of bases in one chain is complementary to the sequence in the other chain, therefore one controls the other. During cell division the two strands of the DNA double helix partly unwind and each serves as the template for the synthesis of a new DNA molecule. DNA replication follows the base pairing rules by which A pairs with T and G pairs with C. Therefore, each daughter molecule is an exact replication of the parent molecule. DNA replication is semi conservative i.e. only half of the parental DNA is conserved and only one strand is synthesised. DNA replication takes place only in 5' → 3' direction.

Q5. Answer the following queries about proteins-

(i) How are proteins related to amino acids?

Ans. Proteins consist of large number of amino acids linked to each other by peptide linkage, having 3- dimensional structure. Thus, proteins are biopolymers of amino acids.

(ii) When is protein said to be denatured?

Ans. When nature proteins are subjected to the action of heat, acids or alkalies, they are coagulated or precipitated. The protein in this state is said to be denatured. During

denaturation process the water soluble form of globular protein change to water insoluble fibrous protein.

SA(II)

3 Marks

Q6. Draw simple Fischer projections of D and L- glucose. Are these enantiomers?

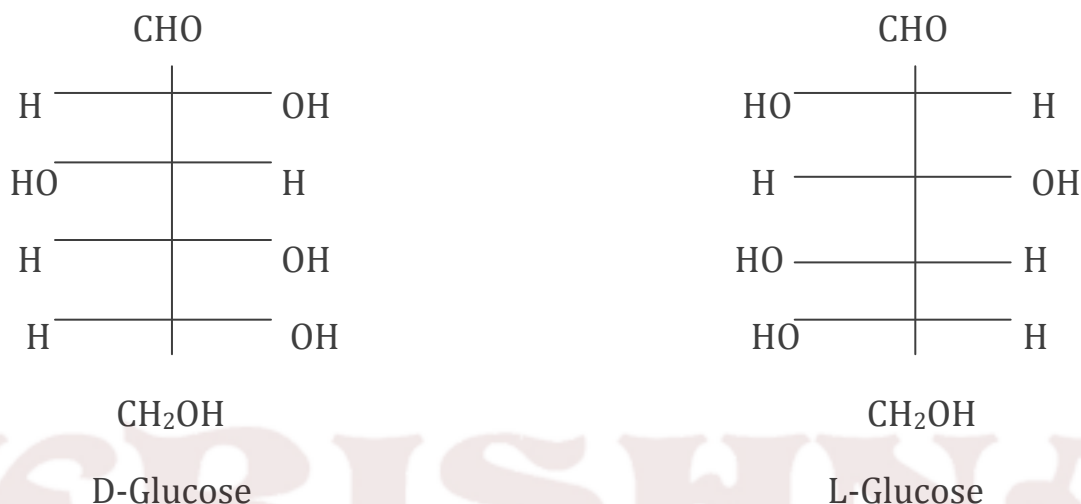

Yes these two Fischer projections are called enantiomers.

Q7. A tripeptide on complete hydrolysis gives glycine, alanine and phenylalanine using three letter symbols write down the possible sequence of tripeptide.

Ans. Each amino acid may be present at the N-terminal as well as C-terminal.

- (i) Gly-Ala-Gly
- (ii) Gly-Phe-Ala
- (iii) Ala-Gly-Phe
- (iv) Ala- Phe-Gly
- (v) Phe-Ala-Gly
- (vi) Phe-Gly-Ala

Q8. Glycine exists as a Zwitter ion but o- and p-amino benzoic acids do not. Explain.

Ans. The lone pair of N-atom in o- and p-aminobenzoic acid is involved in resonance. The lone pair of N-atom is transferred towards benzene ring. This decreases the acidic character of $-\text{NH}_2$ group. Therefore these groups do not transfer and accept H^+ ions, respectively.

Q9. Write short notes on-

(i) Co-enzymes

(ii) Prosthetic groups

Ans. (i) Co-enzymes:- These are usually derived from vitamins such as thiamine, riboflavin, niacin etc. They are loosely held to the protein and can be easily separated by dialysis.

(ii) Prosthetic groups:- They are also derived from vitamins such as biotin but are tightly held to the protein molecule by covalent bonds. They can be separated only by careful hydrolysis.

Q10. The melting points and solubility in water of amino acids are generally higher than that of the corresponding halo acids. Explain.

Ans. The amino acids exist as zwitter ion ($\text{H}_3\text{N}^+\text{—CHR—COO}^-$). They have salt like structure. There are strong dipole-dipole and electrostatic attractions. Therefore, amino acids have high melting points. Amino acids strongly interact with water molecules and are soluble in it. The halo-acids do not have salt like structure and have low melting points. Halo-acids do not interact as strongly with water molecules as do amino acids. Therefore, solubility of amino acids in water is more than those of halo-acids.

POLYMERS

GIST

1. Polymer:

It is a very large molecule having molecular mass $10^3 - 10^7 \text{ g mol}^{-1}$. They are formed by joining together repeating structural units.

2. Classification of Polymers:

(a) Based On Source:

(i) Natural: Found in plants and animals, e.g. Proteins, cellulose, natural rubber, silk, wool.

(ii) Synthetic: Man-made e.g. Nylon, polyester, neoprene, Bakelite, Teflon, PVC, polystyrene.

(b) Based On Structure:

(i) Linear Polymers: this consist of long and straight chain repeating units e.g. Polythene (HDPE), PVC, nylon, polyester.

(ii) Branched Polymers: This contain linear chains having some branches e.g. amylopectin, glycogen etc.

(iii) Cross Linked Polymers: Strong covalent bonds are present between various linear polymer chains. E.g. Bakelite, urea- formaldehyde polymer, melamine, formaldehyde polymer etc.

(c) Based On Mode Of Polymerization:

(i) Addition Polymers: These are formed by the repeated addition of monomer molecules possessing multiple bonds, e.g., polythene, polypropene, polystyrene, PMMA (polymethyl methacrylate)

(ii) Condensation Polymers: These are formed by the repeated condensation reaction of different bifunctional or trifunctional monomers, with the elimination of small molecules like water, HCl, NH₃, alcohol etc. e.g. Bakelite, nylon, polyester, urea-formaldehyde resin.

(d) Based On Molecular Forces:

(i) Elastomers: Forces of interaction between polymer chains is weakest, e.g. natural rubber, neoprene, vulcanized rubber.

(ii) Fibers: Strong hydrogen bonds are present between the polymer chains. They have high tensile strength e.g., nylon, polyester, silk, wool, orlon, rayon etc.

(iii) Thermoplastics: They are linear/slightly branched chain molecules capable of repeated softening on heating and hardening on cooling, e.g., polythene, PVC, polystyrene, polypropene.

(iv) Thermosetting Plastics: They are cross-linked or heavily branched molecules, which on heating undergo extensive cross-linkages and become infusible, e.g., bakelite, urea-formaldehyde resin.

(e) Based On Growth Of Polymerization: Depending upon the mechanism of Polymerization, polymers are classified as

(i) Addition Polymers Or Chain Growth Polymers:

They follow mostly free radical mechanism.

(ii) Condensation Polymers or Step Growth Polymers
because they are formed in gradual steps.

Polymer	Monomer	Uses
(i) Polyethene	Ethene	Insulation of wires, toys, manufacture of dustbins etc.
(ii) Polytetra Fluroethene(Teflon)	Tetrafluoroethene	Oil seal and Gasket and non Stick kitchen wares
(iii) Polyacrylonitrile	Acrylonitrile	Substitute for wool
(iv) Terylene or Decron	Glycol + Terephthalic Acid	Ropes, safety belts, tyre -cord , sails of boats, saree and dress material
(v) Nylon-6,6	Hexamethylenediamine + Adipic acid	Stocking, socks, ropes, Parachutes, fabrics, bristles of tooth brush
(vi) Nylon-6	Caprolactum	Tyre-cords, Ropes, fabrics
(vii) Novolac	Phenol + Formaldehyde	Used for binding glue, laminated wooden planks
(viii) Phenol Formaldehyde resin	Formaldehyde + Phenol	Combs, records, switches boards
(ix) Melamine polymers	Melamine + Formaldehyde	Manufacture of unbreakable crockery
(x) Buna-S Copolymer	1,3-Butadiene + Styrene	Autotyres floor, tiles foot-wear components
(xi) Natural rubber	2-methyl-1,3-butadiene	Used for tyres
(xii) Neoprene	2-chloro-1,3-butadiene	Conveyor belts, gasket , hoses
(xiii) Buma-N	1,3-butadiene + acrylonitrile	Resistance to action of petrol. Make oil seals, tank linings etc.
(xiv) (PHBV) poly- β hydroxybutyrateco- β - hydroxyl valerate (biodegradable)	3-hydroxybutanoic acid + 3-hydroxypantanoic acid	Packaging orthopaedic devices
(xv) Nylon-2-nylon-6	Glycine + aminocaproic acid	It is biodegradable step growth Polymer
(xvi) Poly(glycolic acid) Poly(lactic acid) (dexton) (biodegradable)	Glycolic acid + lactic acid	Sutures ,ie,for stitching wounds after operation. Biodegradables

VSA (1 marks)

1. Name a natural elastomer.

Ans . Natural rubber.

2. Write name of a synthetic polymer which is an ester.

Ans. Nylon 6 or Nylon 6,6.

3. Name of monomer of Nylon 6.

Ans. ϵ - Aminocaproic acid

4. Write the monomer units of Bakelite.

Ans. Phenol and formaldehyde.

5. Define a copolymer.

Ans. The polymers made by addition polymerisation from two different

monomers are termed as **copolymers**, e.g., Buna-S, Buna-N, etc.

6. Write one use of PVC.

Ans: In manufacture of rain coats & vinyl flooring.

7. Define Polymer.

Ans: Polymer is defined as very large molecules having molecular mass (10³-10⁷u). These are also referred to as **macromolecules**,

8. Give an example of thermoplastics.

Ans: Thermoplastics are polythene, polystyrene, polyvinyls, etc.

9. To which class of polymers does Nylon-66 belong?

Ans: **Polyamides**

10. Name the type of monomers in terylene?

Ans: Ethylene glycol and terephthalic acid.

SA-1 (2 marks)

1. Arrange the following polymers in increasing order of their intermolecular forces.

(i) Nylon 6,6, Buna-S, Polythene.

(ii) Nylon 6, Neoprene, Polyvinyl chloride.

Ans. (i) Buna-S < Polythene < Nylon 6,6

(ii) Neoprene < Polyvinyl chloride < Nylon 6.

2. Classify the following as addition and condensation polymers:
Terylene, Bakelite,
Polyvinyl chloride, Polythene.

Ans. (i) addition polymers :Polyvinyl chloride, Polythene.

(ii) condensation polymers: Terylene , Bakelite.

3. What is a biodegradable polymer ? Give an example of a biodegradable aliphatic polyester.

Ans. Polymers which disintegrate by themselves over a period of time due to environmental degradation by bacteria,etc.are called biodegradable polymers. e.g. PHBV

4.How can you differentiate between addition and condensation polymerization

Ans. In addition polymerization the molecules of the same monomer or diferent monomers add together on a large scale to form a polymer. The monomers used are unsaturated compounds, *e.g.*, alkenes, alkadienes and their derivatives.

Condensation polymerisation generally involves a repetitive condensation reaction between two bi-functional monomers. These polycondensation reactions may result in the loss of some simple molecules as water, alcohol, etc., and lead to the formation of high molecular mass condensation polymers. *e.g.* , Nylon 6,6.

5.What is meant by PTFE ?Give its popular name.

Ans.Polytetrafluoroethylene.it is called Teflon.

6.Write chemical name of (Ziegler-Natta catalyst).

Ans: Triethylaluminium and titanium tetrachloride

7.Write down the two differences between thermoplastic and thermosetting plastic and examples.

Ans: Thermoplastic are the linear or slightly branched long chain molecules

capable of repeatedly softening on heating and hardening on cooling.

These polymers possess intermolecular forces of attraction intermediate between elastomers and fibres. Some common thermoplastics are polythene, polystyrene, polyvinyls, etc.

Thermosetting plastic polymers are cross linked or heavily branched molecules, which on heating undergo extensive cross linking in moulds and again become infusible. These cannot be reused. Some common examples are bakelite, urea-formaldelyde resins, etc.

8. Differentiate Novolac and Bakelite on the basis of structure.

Ans: A linear product of *Phenol - formaldehyde polymer* is **Novolac**, used in paints.

Novolac on heating with formaldehyde undergoes cross linking to form an infusible solid mass called **bakelite**. It is used for making combs, phonograph records, electrical switches and handles of various utensils.

9. Distinguish between the terms homopolymer and copolymer and give an example of each.

Ans: the addition polymers formed by the polymerisation of a single monomeric species are known as **homopolymers**, *e.g.*, polythene.

The polymers made by addition polymerisation from two different monomers are termed as **copolymers**, *e.g.*, Buna-S, Buna-N, etc.

10. How will you differentiate between LDP and HDP?

Ans: **Low density polythene**: It is obtained by the polymerisation of ethene under high pressure of 1000 to 2000 atmospheres at a temperature of 350 K to 570 K in the presence of traces

of dioxygen or a peroxide initiator (catalyst).

Low density polythene is chemically inert and tough but flexible and a poor conductor of electricity.e.g., squeeze bottles, toys and flexible pipes.

High density polythene: It is formed when addition polymerisation of ethene takes place in a hydrocarbon solvent in the presence of a catalyst Ziegler-Natta catalyst at a temperature of 333 K to 343 K and under a pressure of 6-7 atmospheres. HDP consists of linear molecules and has a high density due to close packing. It is more tougher and harder. It is used for manufacturing buckets, dustbins, bottles, pipes, etc.

SA-II (3 marks)

1. Write the names of monomers of the following polymers:

(i) Nylon 6,6 (ii) Neoprene(iii) Buna -N

Ans. (i) hexamethylenediamine and adipic acid.

(ii) chloroprene.

(iii) 1, 3 - butadiene and acrylonitrile.

3.How are polymers classified on the basis of structure?

Ans.On the basis of structure, the polymers are classified as below:

(i) Linear polymers such as polythene, polyvinyl chloride,HDP etc.

(ii) Branched chain polymers such as low density polythene,LDP,etc.

(iii) Cross linked polymers such as bakelite, melamine, etc.

4. Write the monomers of the following polymers:

(i) Buna-N (ii) Teflon(iii) Neoprene.

Ans.(i) 1, 3 - butadiene and acrylonitrile (ii) *tetrafluoroethene* (iii) chloroprene.

6. Write use of each orion and Nylon-6.

Ans: use of orion is clothing as a substitute for wool& for Nylon-6.

use of Nylon-6 is as fibrics

8. Explain elastomeric polymers & Fibres

Ans: These are rubber – like solids with elastic properties. In these elastomeric polymers, the polymer chains are held together by the weakest intermolecular forces. These weak binding forces permit the

polymer to be stretched. A few ‘crosslinks’ are introduced in between

the chains, which help the polymer to retract to its original position after the force is released as in vulcanised rubber. The examples are buna-S, buna-N, neoprene, etc.

Fibres are the thread forming solids which possess high tensile strength and high modulus. These characteristics can be attributed to the strong intermolecular forces like hydrogen bonding. These strong forces also lead to close packing of chains and thus impart crystalline nature. The examples are polyamides (nylon 6, 6), polyesters (terylene), etc.

9 . What is the function of sulphur in vulcanisation of rubber?

Ans: Sulphur introduces sulphur bridges. So it becomes more tensile strength, elasticity and resistance to abrasion etc.

10. Write Commercially Important of following Polymers

(1) Polypropene (2) Polystyrene (3) Glyptal

Ans: (1) Manufacture of ropes, toys, pipes, fibres, etc.

(2) As insulator, wrapping material, manufacture of toys, radio and television cabinets.

(3) Manufacture of paints and lacquers.

HOTS QUESTIONS

VSA (1mark)

1. What is the main constituent of bubble gum?

Ans - Styrene - butadiene copolymer (SBR).

2. What is a plasticizer?

Ans; The substances which are added to increase the softness of hard polymers.

3. Draw the structures of the monomer of PAN.

Ans: $\text{CH}_2=\text{CH}-\text{CN}$

4. Give the name of polymer which is used for making non-stick utensils.

Ans: Teflon ($\text{CF}_2=\text{CF}_2$)

5. What is the % of sulphur used during vulcanization of rubber?

Ans: 3% to 5%

SA-I(2 marks)

1. Give the common and the IUPAC name of the monomer of natural rubber.

Ans: cis-Isoprene & 2-methyl-1,3-butadiene

2. Discuss the two main purposes of vulcanization of rubber.

Ans: (i) It makes the rubber hard.

(ii) It is more elastic.

(iii) It has more wear and tear resistance.

3. Explain the term *Thermosetting polymers* and give one example.

Ans: *Thermosetting polymers*: These polymers are cross-linked or heavily branched molecules, which on heating undergo extensive cross-linking in moulds and again become infusible. These cannot be reused. Some common examples are bakelite, urea-formaldehyde resins, etc.

4. Why should one always use purest monomer in free radical polymerisation?

Ans: Impurities of other substances if present, may inhibit or hinder the chain propagation.

5. How is dacron obtained from ethylene glycol and terephthalic acid?

Ans: It is the condensation product of ethylene glycol and terephthalic acid

Carried out at 420 to 460K in the presence of catalyst mixture of zinc acetate and antimony trioxide.

SA-II(3 marks)

1. What do the following polymers stand for ?

(i) PVC (ii) DOP (iii) PAN

Ans: (1) Polyvinylchloride

(2) Dioctylphthalate

(3) Polyacrylonitrile

2. Why is Bakelite a thermosetting polymer?

Ans: It is a cross-linked polymer. On heating it sets permanently into a solid. It can not be remoulded by heating again.

3. A regular copolymer of ethylene and vinyl chloride contains alternate monomers of each type. What is the weight percent of ethylene in this copolymer?

Ans: the weight percent of ethylene in this copolymer

$$[28/(28+62.5)] \times 100$$

30.93%

4. $C_6H_{10}NOH \xrightarrow{\text{Acid polymerisation}} A \rightarrow B$ Give the products A & B.

A = ϵ -Aminocaproic acid

B = nylon-6

5. (i) Give an example of a synthetic rubber.

(ii) Mention main advantage of synthetic rubber.

(iii) Arrange the polymers in the increasing order of tensile strength,

Nylon-6, Buna-S, Polythene.

Ans: (i) synthetic rubber is Buna-S

(ii) It is used for making oil seals, tank linings.

(iii) Buna-S < Polythene < Nylon-6

Unit-16 CHEMISTRY IN EVERYDAY LIFE

POINTS TO BE REMEMBERED

- 1. DRUGS** – Drugs are chemical of low molecular masses, which interact with macromolecular targets and produce a biological response.
- 2. CHEMOTHERAPY**- The use of chemicals for therapeutic effect is called chemotherapy.
- 3. CLASSIFICATION OF DRUGS** –
 - (a) ON THE BASIS OF PHARMACOLOGICAL EFFECT**-drugs for a particular type of problem as analgesics----for pain relieving.
 - (b) ON THE BASIS OF DRUG ACTION**-Action of drug on a particular biochemical process.
 - (c) ON THE BASIS OF CHEMICAL ACTION**-Drugs having similar structure .eg-sulpha drugs.
 - (d) ON THE BASIS OF MOLECULAR TARGETS**- Drugs interacting with biomolecules as lipids, proteins.
- 4. ENZYMES AS DRUG TARGETS**
 - (i) CATALYTIC ACTION OF EN ZYMES**-
 - (a)** Enzymes have active sites which hold the substrate molecule .it can be attracted by reacting molecules.
 - (b)** Substrate is bonded to active sites through hydrogen bonds, ionic bonds, Vander Waal or dipole –dipole interactions.
 - (ii) DRUG- ENZYME INTERACTIONS**-
 - (a)**Drug complete with natural substrate for their attachments on the active sites of enzymes .They are called competitive inhibitors.
 - (b)**Some drugs binds to a different site of the enzyme called allosteric sites which changes the shape of active sites.
- 5. ANTAGONISTS**- The drugs that bind to the receptor site and inhibit its natural function.
- 6. AGONISTS**-Drugs mimic the natural messenger by switching on the receptor.
- 7. ANTACIDS**-These are compounds which neutralize excess acid of stomach.eg-Aluminium hydroxide, Magnesium hydroxide.
- 8. ANTI HISTAMINES**-The drugs which interfere with the natural action of histamines and prevent the allergic reaction. eg- rantidine,tegarnet, avil.
- 9. TRANQUILIZERS**-The class of chemical compounds used for the treatment of stress,mild or even severe mental diseases. Eg-idardil, iproniagid, luminal, second equaquil .
- 10. ANALGESICS**-They reduce pain without causing impairment of consciousness, mental confusion or some other disturbance of the nervous system.
Eg - aspirin, seridon , phenacetin.
- 11. ANTIMICROBIALS**-They tend to prevent/destroy or inhibit the pathogenic action of microbes as bacteria ,virus ,fungi etc .They are classified as
 - (i)ANTIBIOTICS**-Those are the chemicals substances which are produced by micro-organisms.

Eg- Pencillin , ofloxacin .

NARROW SPECTRUM ANTI-BIOTICS-These are effective mainly against gram positive or gram negative bacteria. Eg- Penicillin , streptomycin.

BROAD SPECTRUM ANTI-BIOTICS-They kill or inhibit a wide range of micro-organisms.
eg- chloramphenicol , tetracycline .

(ii)**ANTISEPTICS OR DISINFECTANT**-These are which either kill/inhibit the growth of micro-organisms

Antiseptics are applied to the living tissues such as wounds, cuts, ulcers etc. eg- furacine, chloroxylenol & terpinol(dettol) .Disinfectant are applied to inanimate objects such as floors , drainage , system.

Eg- 0.2% solution of phenol is an antiseptic while 1% solution is an disinfectant.

12. **ANTIFERTILITY DRUGS**- These is the chemical substances used to control the pregnancy. They are also called oral contraceptives or birth control pills.

Eg-Mifepristone, norethindrone.

13. **ARTIFICIAL SWEETNING AGENTS**-These are the chemical compounds which give sweetening effect to the food without adding calorie.

They are good for diabolic people eg- aspartame, saccharin, alitame , sucralose.

14. **FOOD PRESERVATIVES**- They prevents spoilage of food to microbial growth.eg-salt, sugar, and sodium benzoate.

15. **CLEANSING AGENTS**-

(i) **SOAPS**- They is sodium or potassium salts of long chain fatty acids.They are obtained by the soapnification reaction, when fatty acids are heated with aqueous sodium hydroxide.

They do not work well in hard water.

(iii) **TOILETS SOAP**-That are prepared by using better grade of fatty acids and excess of alkali needs to be removed .colour & perfumes are added to make them attractive.

(iv) **MEDICATED SOAPS**- Substances of medicinal value are added.eg- Buthional , dettol.

16. **SYNTHETIC DETERGENTS**-They are cleaning agents having properties of soaps, but actually contain no soap .They can used in both soft and hard water .They are-

(i)**ANIONIC DETERGENTS**-They are sodium salts of sulphonated long chain alcohols or hydrocarbons.eg-sodium lauryl sulphonate . They are effective in acidic solution.



(laurylalcohol)



(Sodium lauryl sulphonate)

(ii)**CATIONIC DETERGENTS**- They are quarternary ammonium salts of amines with acetates , chlorides, or bromides.They are expensive used to limited extent.eg- cetyltrimethylammoniumbromide

(iii)**NON-IONIC DETERGENTS**- They does not contain any ions. Some liquid dishwashing detergents which are of non-ionic type .

(ii) **Antibiotics**-The drugs which prevent the growth of other micro-organisms. Eg- Pencillin.

Q-3 Name the medicines used for the treatment of the following-

(i) Tuberculosis (ii) Typhoid Tuberculosis- Sterptomycin

Typhoid- Chlororophenicol

Q-4 what are tincture of iodine?

Ans-4 2-3% iodine solution of alcohol water is called tincture of Iodine. It is a powerful antiseptics and is applied on wounds.

Q- 5 What is artificial sweetening agent? Give two examples?

Ans-5 The substances which give sweetening to food but don't add calorie to our body .

Eg- Saccharin, alitame.

Q-6 How is synthetic detergents better than soaps?

Ans- 6 (i) Detergents can be used in hard water but soaps cannot be used.

(ii) Detergents have a stronger cleansing action than soaps.

Q-7 what are sulpha drugs? Give two examples?

Ans-7 a group of drugs which are derivatives of sulphanilamide and are used in place of antibiotics is called sulpha drugs.

Eg- sulphadizine, sulphanilamide.

Q-8 what forces are involved in holding the active sites of the enzymes?

Ans-8 The forces are involved in holding the active sites of the enzymes are hydrogen bonding , ionic bonding , dipole-dipole attractions or Vander waals force of attractions.

Q-9 Describe the following giving an example in each

case- (i) Edible colours

(ii) Antifertility drugs

(i) **Edible colours**- They are used for dyeing food.

Eg- saffron is used to colour rice.

(ii) **Antifertility drugs**- Those drugs which control the birth of the child are called antifertility drugs.

Q-10 Give two examples of organic compounds used as antiseptics?

Ans-10 Phenol (0.2%), iodoform

SHORT ANSWER TYPE QUESTION

(3 marks)

Q-1 what are Biodegradable and non-biodegradable detergents? Give one example of each.

Ans-1 Detergents having straight hydrocarbon chain and are easily decomposed by micro-organisms are called **Biodegradable detergents**. The detergents having branched hydrocarbon chain and are not easily decomposed by micro-organisms are called **Non-Biodegradable detergents**.

Q-2 what are barbiturates? To which class of drugs do they belong? Give two examples.

Ans-2 Derivatives of barbituric acid are called barbiturates. They are tranquilizers. They also act as hypnotics. eg- luminal , seconal.

Q-3 what is the use of –

(i) Benadryl (ii) sodium benzoate (iii) Progesterone

Ans-3 (i) Antihistamines

(ii) Preservatives

(iii) Antifertility drug

Q-4 Identify the type of drug-

(i) Ofloxacin (ii) Aspirin (iii) Cimetidine

Ans- 4 (i) Antibiotic (ii) Analgesics & Antipyretics

(iii) Antihistamines & antacid

Q-5 Describe the following with suitable example-

(i) Disinfectant (ii) Analgesics

(iii) Broad spectrum antibiotics

(i) Disinfectant- chemicals used to kill the micro-organisms can applied on non living articles.

(ii) Analgesics- They are the drugs which are used to relieve pain . eg – Aspirin , Ibuprofen.

(iii) Broad spectrum antibiotics- They kill the wide range of gram positive and gram negative bacteria.

Eg- Chloramphenicol , ofloxacin.

**KRISHNA
PUBLIC SCHOOL**